



LM2901B

LINEAR INTEGRATED CIRCUIT

QUAD DIFFERENTIAL COMPARATOR

DESCRIPTION

The UTC **LM2901B** consists of four independent voltage comparators, designed specifically to operate from a single power supply over a wide voltage range.

FEATURES

- * Signal or Dual Supply Operation
- * Wide Operating Supply Range
($V_{CC}=2V \sim 36V$ or $\pm 1 \sim \pm 18V$)
- * Input Common-Mode Voltage Includes Ground.
- * Low Supply Current $I_{CC}=0.8mA$ (Typical)
- * Open Collector Outputs for Wired and Connection
- * Low Output Saturation Voltage
- * Output Compatible with TTL, DTL, and CMOS Logic System
- *High ESD (2kV, HBM)

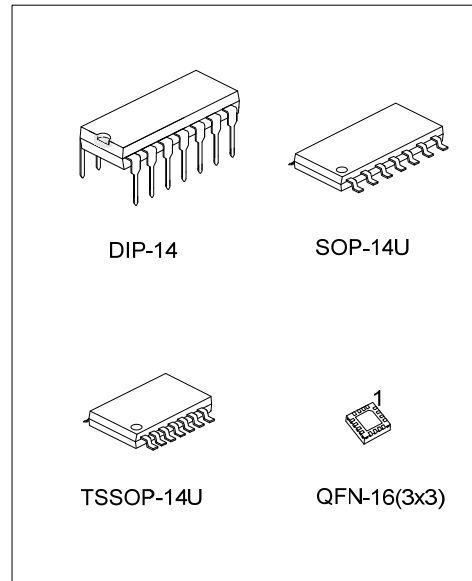

ORDERING INFORMATION

Ordering Number		Package	Packing
Lead Free	Halogen-Free		
LM2901BL-D14-T	LM2901BG-D14-T	DIP-14	Tube
LM2901BL-UEA-R	LM2901BG-UEA-R	SOP-14U	Tape Reel
LM2901BL-UEB-R	LM2901BG-UEB-R	TSSOP-14U	Tape Reel
LM2901BL-Q16-3030-R	LM2901BG-Q16-3030-R	QFN-16(3x3)	Tape Reel

<p>LM2901BG-D14-T</p> <p>(1)Packing Type (2)Package Type (3)Green Package</p>	<p>(1) T: Tube, R: Tape Reel (2) DIP: DIP-14, UEA: SOP-14U, UEB: TSSOP-14U Q16-3030: QFN-16(3x3) (3) G: Halogen Free and Lead Free, L: Lead Free</p>
---	--

LM2901B

LINEAR INTEGRATED CIRCUIT

MARKING

PACKAGE	MARKING
DIP-14	<p> Date Code L: Lead Free G: Halogen Free Lot Code </p>
SOP-14U TSSOP-14U	<p> Date Code L: Lead Free G: Halogen Free Lot Code </p>
QFN-16(3x3)	<p> L: Lead Free G: Halogen Free Date Code Lot Code </p>

PIN CONFIGURATION

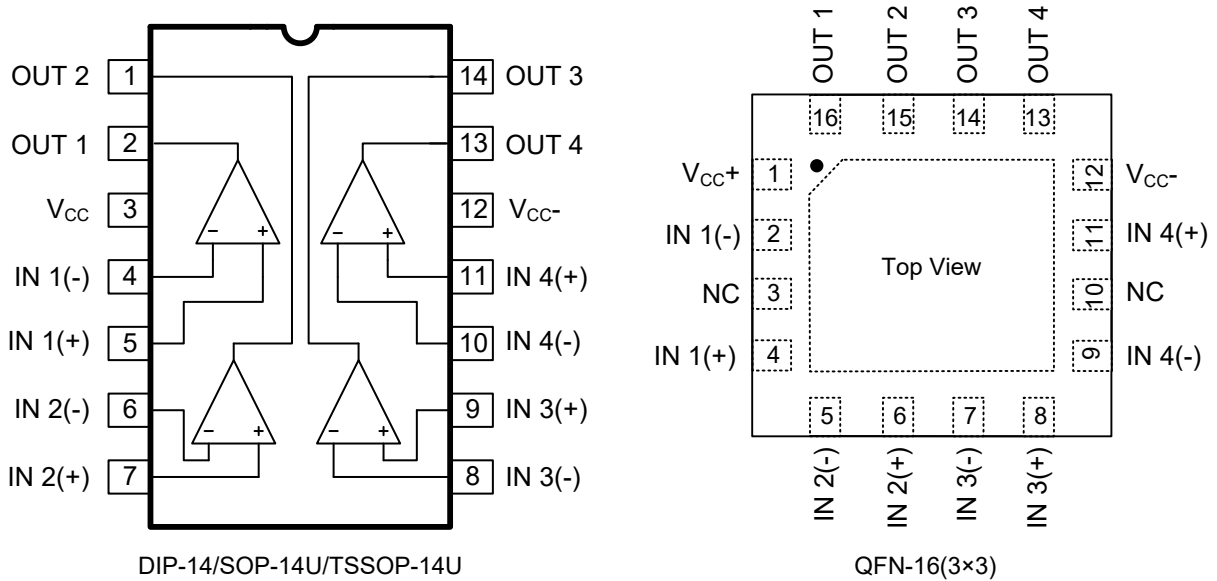

■ BLOCK DIAGRAM

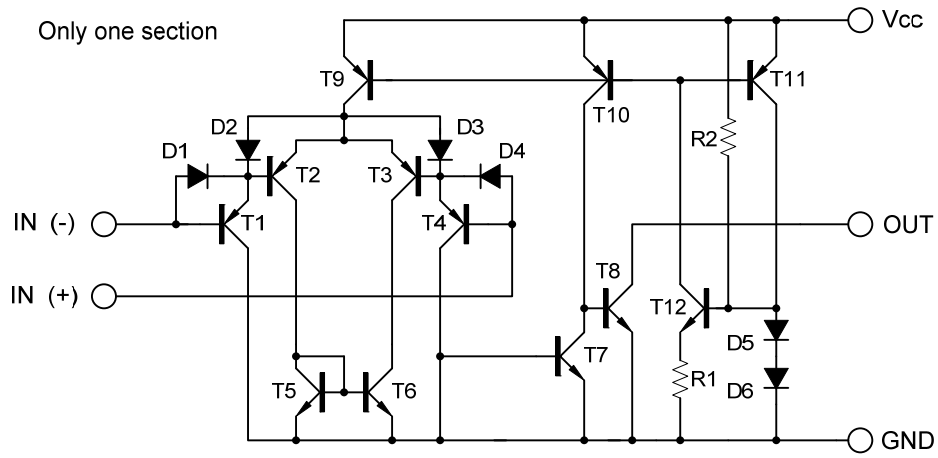

■ ABSOLUTE MAXIMUM RATINGS (T_A=25°C, unless otherwise specified)

PARAMETER		SYMBOL	RATINGS	UNIT
Supply Voltage		V _{CC}	38	V
Differential input Voltage		V _{I(DIFF)}	±38	V
Input Voltage		V _{IN}	-0.3 ~ 38	V
Power Dissipation	DIP-14	P _D	900	mW
	SOP-14		560	mW
	TSSOP-14		440	mW
	QFN-16(3×3)		1300	mW
Electrostatic Discharge	Human-Body Model (HBM) Per JESD22-A114/115	V _(ESD)	2000	V
Junction Temperature		T _J	+150	°C
Operating Temperature		T _{OPR}	-40 ~ +125	°C
Storage Temperature		T _{STG}	-65 ~ +150	°C

Notes: 1. Absolute maximum ratings are those values beyond which the device could be permanently damaged.

Absolute maximum ratings are stress ratings only and functional device operation is not implied.

2. It is guarantee by design, not 100% be tested.

■ ELECTRICAL CHARACTERISTICS

(V_{CC}=5.0V, All voltage referenced to GND unless otherwise specified)

PARAMETER	SYMBOL	TEST CONDITIONS	MIN	TYP	MAX	UNIT
Supply Current	I _{CC}	R _L =∞, V _{CC} =5V		0.8	1.3	mA
		V _{CC} =36V, T _A = Full range			2.0	mA
Input Offset Voltage	V _{I(OFF)}	V _{CM} =0V to V _{CC} -1.5V V _{O(P)} =1.4V, R _S =0Ω		1.5	3.0	mV
		T _A = Full range			5.5	mV
Input Offset Current	I _{I(OFF)}			2.3	25	nA
		T _A =- Full range			50	nA
Input Bias Current	I _{I(BIAS)}			9	25	nA
		T _A = Full range			50	nA
Input Common Mode Voltage	V _{I(CM)}	V _{CC} =3~36V	0		V _{CC} -1.5	V
		T _A = Full range	0		V _{CC} -2.0	V
Large Signal Voltage Gain	G _V	V _{CC} =15V, R _L >15kΩ	50	200		V/mV
Output Saturation Voltage	V _{SAT}	V _{I(-)} >1V, V _{I(+)} =0V, I _{SINK} =4mA		100	400	mV
		T _A = Full range			550	mV
Output Sink Current	I _{O(SINK)}	V _{I(-)} >1V, V _{I(+)} =0V, V _{O(P)} <1.5V	6	15		mA
Output Leakage Current	I _{O(LEAK)}	V _{I(+)} =1V, V _{I(-)} =0V, V _{OUT(P)} = 5V		5	50	nA
		V _{OUT(P)} =36V			100	nA
Large Signal Response Time	t _R	V _{IN} =TTL logic wing V _{REF} =1.4V, V _{RL} =5V, R _L =5.1kΩ,		300		ns
Response Time	t _R	V _{RL} =5V, R _L =5.1kΩ		1400		ns

TYPICAL CHARACTERISTICS

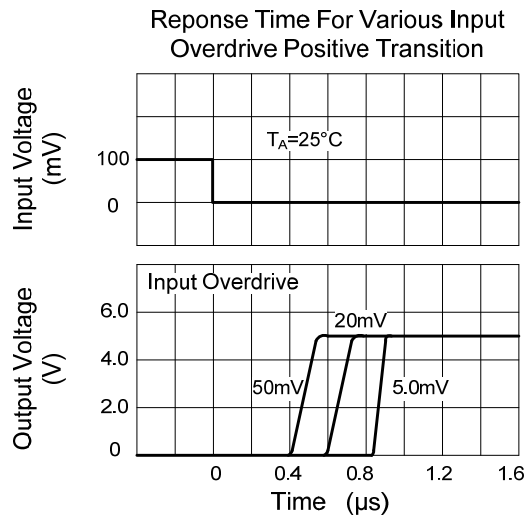
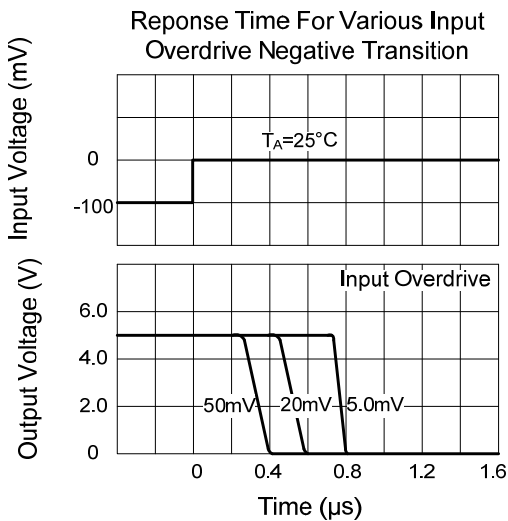
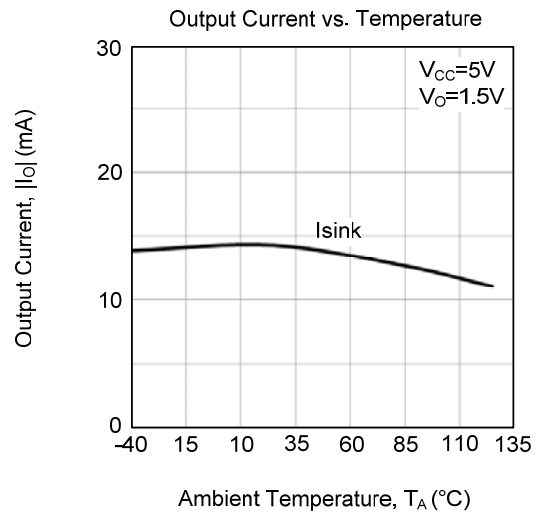
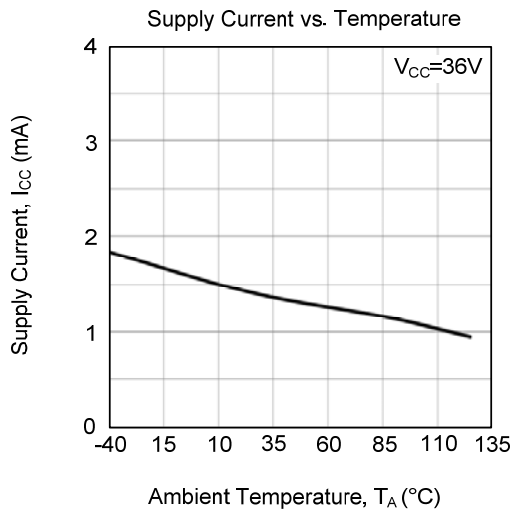

UTC assumes no responsibility for equipment failures that result from using products at values that exceed, even momentarily, rated values (such as maximum ratings, operating condition ranges, or other parameters) listed in products specifications of any and all UTC products described or contained herein. UTC products are not designed for use in life support appliances, devices or systems where malfunction of these products can be reasonably expected to result in personal injury. Reproduction in whole or in part is prohibited without the prior written consent of the copyright owner. UTC reserves the right to make changes to information published in this document, including without limitation specifications and product descriptions, at any time and without notice. This document supersedes and replaces all information supplied prior to the publication hereof.