



USSN4340

Preliminary

NPN EPITAXIAL SILICON TRANSISTOR

40V, 3.0A NPN LOW $V_{CE(SAT)}$ TRANSISTOR

■ DESCRIPTION

The UTC **USSN4340** is an NPN low $V_{CE(SAT)}$ Breakthrough.

■ FEATURES

- * Low collector-emitter saturation voltage $V_{CE(SAT)}$
- * High collector current capability: I_C and I_{CM}
- * Higher efficiency leading to less heat generation
- * Reduced printed-circuit board requirements
- * Complement: USSP4340

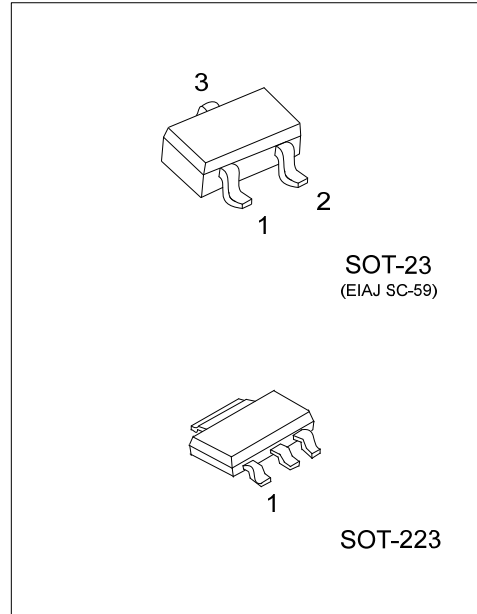

■ ORDERING INFORMATION

Ordering Number		Package	Pin Assignment			Packing
Lead Free	Halogen Free		1	2	3	
USSN4340L-AA3-R	USSN4340G-AA3-R	SOT-223	B	C	E	Tape Reel
USSN4340L-AE3-R	USSN4340G-AE3-R	SOT-23	B	E	C	Tape Reel

Note: Pin Assignment: B: Base C: Collector E: Emitter

<p>USSN4340G-AA3-R</p>	<p>(1) R: Tape Reel</p> <p>(2) AA3: SOT-223, AE3: SOT-23</p> <p>(3) G: Halogen Free and Lead Free, L: Lead Free</p>
------------------------	---

■ MARKING

SOT-223	SOT-23

■ ABSOLUTE MAXIMUM RATING ($T_A=25^{\circ}\text{C}$, unless otherwise specified)

PARAMETER		SYMBOL	RATINGS	UNIT
Collector-Base Voltage		V_{CB0}	40	V
Collector-Emitter Voltage		V_{CE0}	40	V
Emitter-Base Voltage		V_{EB0}	5	V
Collector Current	DC	I_C	3	A
	Peak	I_{CM}	4	A
Power Dissipation ($T_A \leq 25^{\circ}\text{C}$)	SOT-223	P_D	1	W
	SOT-23		0.35	W
Junction Temperature		T_J	+150	$^{\circ}\text{C}$
Storage Temperature		T_{STG}	-65 ~ +150	$^{\circ}\text{C}$

Notes: 1. Absolute maximum ratings are those values beyond which the device could be permanently damaged. Absolute maximum ratings are stress ratings only and functional device operation is not implied.
2. Device mounted on a FR4 printed-circuit board, single-sided copper; tin-plated, mounting pad for collector 1 cm².

■ THERMAL DATA

PARAMETER		SYMBOL	RATINGS	UNIT
Junction to Ambient	SOT-223	θ_{JA}	125	$^{\circ}\text{C/W}$
	SOT-23		357	$^{\circ}\text{C/W}$
Junction to Case	SOT-223	θ_{JC}	26	$^{\circ}\text{C/W}$
	SOT-23		260	$^{\circ}\text{C/W}$

Note: Device mounted on a FR4 printed-circuit board, single-sided copper; tin-plated, mounting pad for collector 1 cm².

■ ELECTRICAL CHARACTERISTICS ($T_A=25^{\circ}\text{C}$, unless otherwise specified)

PARAMETER	SYMBOL	TEST CONDITIONS	MIN	TYP	MAX	UNIT
Collector-Base Breakdown Voltage	BV_{CB0}	$I_C=100\mu\text{A}$, $I_E=0$	40			V
Collector-Emitter Breakdown Voltage	BV_{CE0}	$I_C=1\text{mA}$, $I_B=0$	40			V
Emitter-Base Breakdown Voltage	BV_{EB0}	$I_E=100\mu\text{A}$, $I_C=0$	5			V
Collector-Base Cut-Off Current	I_{CBO}	$V_{CB}=40\text{V}$, $I_E=0$			100	nA
		$V_{CB}=40\text{V}$, $I_E=0$, $T_J=150^{\circ}\text{C}$			50	μA
Collector-Emitter Cut-Off Current	I_{CES}	$V_{CE}=40\text{V}$, $V_{BE}=0$			100	nA
Emitter-Base Cut-Off Current	I_{EBO}	$V_{EB}=5\text{V}$, $I_C=0$			100	nA
Collector-Emitter Saturation Voltage (Note)	$V_{CE(SAT)}$	$I_C=100\text{mA}$, $I_B=1\text{mA}$			60	mV
		$I_C=500\text{mA}$, $I_B=50\text{mA}$			80	mV
		$I_C=1\text{A}$, $I_B=50\text{mA}$			100	mV
		$I_C=2\text{A}$, $I_B=200\text{mA}$			180	mV
Base-Emitter Saturation Voltage (Note)	$V_{BE(SAT)}$	$I_C=1\text{A}$, $I_B=100\text{mA}$			1.1	V
		$I_C=2\text{A}$, $I_B=200\text{mA}$			1.15	V
		$I_C=3\text{A}$, $I_B=300\text{mA}$			1.2	V
Base-Emitter Turn-On Voltage(Note)	$V_{BE(ON)}$	$I_C=0.1\text{A}$, $V_{CE}=2\text{V}$			1	V
Dc Current Gain (Note)	h_{FE}	$V_{CE}=2\text{V}$, $I_C=100\text{mA}$	300			
		$V_{CE}=2\text{V}$, $I_C=500\text{mA}$	300			
		$V_{CE}=2\text{V}$, $I_C=1\text{A}$	300			
		$V_{CE}=2\text{V}$, $I_C=2\text{A}$	200			
		$V_{CE}=2\text{V}$, $I_C=3\text{A}$	100			
Transition Frequency	f_T	$V_{CE}=5\text{V}$, $I_C=100\text{mA}$, $f=100\text{MHz}$	100			MHz

Note: Measured under pulsed conditions. Pulse width $\leq 300\mu\text{s}$. Duty cycle $\leq 2\%$,

UTC assumes no responsibility for equipment failures that result from using products at values that exceed, even momentarily, rated values (such as maximum ratings, operating condition ranges, or other parameters) listed in products specifications of any and all UTC products described or contained herein. UTC products are not designed for use in life support appliances, devices or systems where malfunction of these products can be reasonably expected to result in personal injury. Reproduction in whole or in part is prohibited without the prior written consent of the copyright owner. UTC reserves the right to make changes to information published in this document, including without limitation specifications and product descriptions, at any time and without notice. This document supersedes and replaces all information supplied prior to the publication hereof.