



## 26NM65Z-U3

Preliminary

Power MOSFET

### 26A, 650V N-CHANNEL SUPER-JUNCTION MOSFET

#### DESCRIPTION

The **UTC 26NM65Z-U3** is a Super Junction MOSFET Structure and is designed to have better characteristics, such as fast switching time, low gate charge, low on-state resistance and a high rugged avalanche characteristics. This power MOSFET is usually used at AC-DC converters for power applications.

#### FEATURES

- \*  $R_{DS(ON)} \leq 0.14 \Omega @ V_{GS}=10V, I_D=13A$
- \* Fast switching capability
- \* Avalanche energy tested
- \* Improved dv/dt capability, high ruggedness
- \* With ESD Protected: HBM=2KV

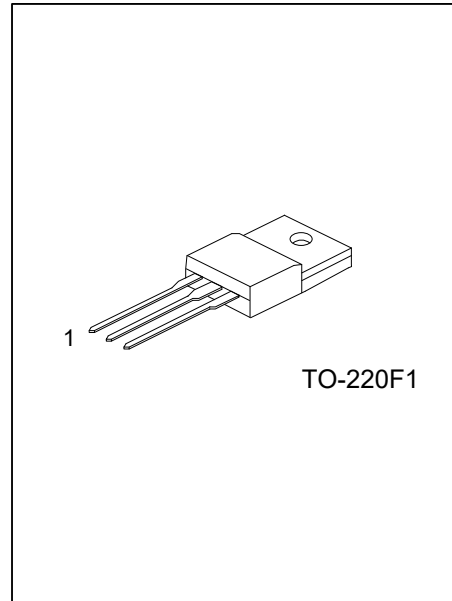

#### SYMBOL

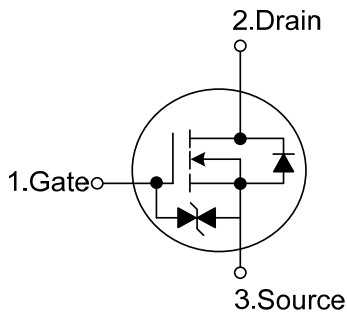

#### ORDERING INFORMATION

Ordering Number		Package	Pin Assignment			Packing
Lead Free	Halogen Free		1	2	3	
26NM65ZL-U3-TF1-T	26NM65ZG-U3-TF1-T	TO-220F1	G	D	S	Tube

Note: Pin Assignment: G: Gate D: Drain S: Source

26NM65ZG-U3-TF1-T	(1)Packing Type	(1) T: Tube
	(2)Package Type	(2) TF1: TO-220F1
	(3)Version Code	(3) Version U3
	(4)Green Package	(4) G: Halogen Free and Lead Free, L: Lead Free

■ MARKING

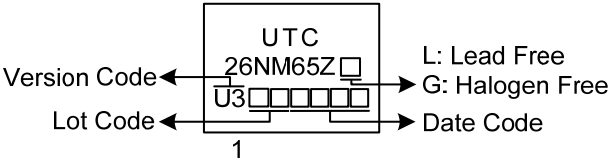

■ ABSOLUTE MAXIMUM RATINGS ( $T_C=25^\circ\text{C}$ , unless otherwise specified)

PARAMETER		SYMBOL	RATINGS	UNIT
Drain-Source Voltage		$V_{DSS}$	650	V
Gate-Source Voltage		$V_{GSS}$	$\pm 20$	V
Drain Current	Continuous $T_C=25^\circ\text{C}$	$I_D$	26	A
	Pulsed (Note 2)	$I_{DM}$	78	A
Avalanche Energy	Single Pulsed (Note 3)	$E_{AS}$	62.5	mJ
Peak Diode Recovery $dv/dt$ (Note 4)		$dv/dt$	1.2	V/ns
Power Dissipation		$P_D$	33	W
Junction Temperature		$T_J$	+150	$^\circ\text{C}$
Storage Temperature		$T_{STG}$	-55 ~ +150	$^\circ\text{C}$

Notes: 1. Absolute maximum ratings are those values beyond which the device could be permanently damaged.

Absolute maximum ratings are stress ratings only and functional device operation is not implied.

2. Repetitive Rating: Pulse width limited by maximum junction temperature.

3.  $L = 10\text{mH}$ ,  $I_{AS} = 3.5\text{A}$ ,  $V_{DD} = 50\text{V}$ ,  $R_G = 25\Omega$  Starting  $T_J = 25^\circ\text{C}$

4.  $I_{SD} \leq 26\text{A}$ ,  $di/dt \leq 200\text{A}/\mu\text{s}$ ,  $V_{DD} \leq BV_{DSS}$ , Starting  $T_J = 25^\circ\text{C}$

■ THERMAL DATA

PARAMETER	SYMBOL	RATINGS	UNIT
Junction to Ambient	$\theta_{JA}$	62.5	$^\circ\text{C}/\text{W}$
Junction to Case	$\theta_{JC}$	3.79	$^\circ\text{C}/\text{W}$

■ ELECTRICAL CHARACTERISTICS (T<sub>J</sub>=25°C, unless otherwise specified)

PARAMETER	SYMBOL	TEST CONDITIONS	MIN	TYP	MAX	UNIT
<b>OFF CHARACTERISTICS</b>						
Drain-Source Breakdown Voltage	BV <sub>DSS</sub>	V <sub>GS</sub> =0V, I <sub>D</sub> =250μA	650			V
Drain-Source Leakage Current	I <sub>DSS</sub>	V <sub>DS</sub> =650V, V <sub>GS</sub> =0V			1	μA
Gate-Source Leakage Current	I <sub>GSS</sub>	V <sub>GS</sub> =±20V, V <sub>DS</sub> =0V			±10	μA
<b>ON CHARACTERISTICS</b>						
Gate Threshold Voltage	V <sub>GS(TH)</sub>	V <sub>DS</sub> =V <sub>GS</sub> , I <sub>D</sub> =250μA	2.5		4.5	V
Static Drain-Source On-State Resistance	R <sub>DS(ON)</sub>	V <sub>GS</sub> =10V, I <sub>D</sub> =13A			0.14	Ω
<b>DYNAMIC CHARACTERISTICS</b>						
Input Capacitance	C <sub>ISS</sub>	V <sub>GS</sub> =0V, V <sub>DS</sub> =50V, f=1MHz		1400		pF
Output Capacitance	C <sub>OSS</sub>			400		pF
Reverse Transfer Capacitance	C <sub>RSS</sub>			14		pF
<b>SWITCHING CHARACTERISTICS</b>						
Total Gate Charge (Note 1)	Q <sub>G</sub>	V <sub>DS</sub> =520V, V <sub>GS</sub> =10V, I <sub>D</sub> =13A (Note 1, 2)		52		nC
Gate-Source Charge	Q <sub>GS</sub>			11		nC
Gate-Drain Charge	Q <sub>DD</sub>			27		nC
Turn-On Delay Time (Note 1)	t <sub>D(ON)</sub>	V <sub>DD</sub> =100V, V <sub>GS</sub> =10V, I <sub>D</sub> =13A, R <sub>G</sub> =25Ω (Note 1, 2)		21		ns
Turn-On Rise Time	t <sub>R</sub>			37		ns
Turn-Off Delay Time	t <sub>D(OFF)</sub>			181		ns
Turn-Off Fall Time	t <sub>F</sub>			77		ns
<b>SOURCE- DRAIN DIODE RATINGS AND CHARACTERISTICS</b>						
Maximum Continuous Drain-Source Diode Forward Current	I <sub>S</sub>				26	A
Maximum Pulsed Drain-Source Diode Forward Current	I <sub>SM</sub>				78	A
Drain-Source Diode Forward Voltage (Note 1)	V <sub>SD</sub>	I <sub>S</sub> =26A, V <sub>GS</sub> =0V			1.4	V
Body Diode Reverse Recovery Time (Note 1)	t <sub>rr</sub>	I <sub>S</sub> =26A, V <sub>GS</sub> =0V, dI <sub>F</sub> /dt=100A/μs		404		nS
Body Diode Reverse Recovery Charge	Q <sub>rr</sub>			6155		nC

Notes: 1. Pulse Test: Pulse width ≤ 300μs, Duty cycle ≤ 2%.

2. Essentially independent of operating temperature.

■ TEST CIRCUITS AND WAVEFORMS

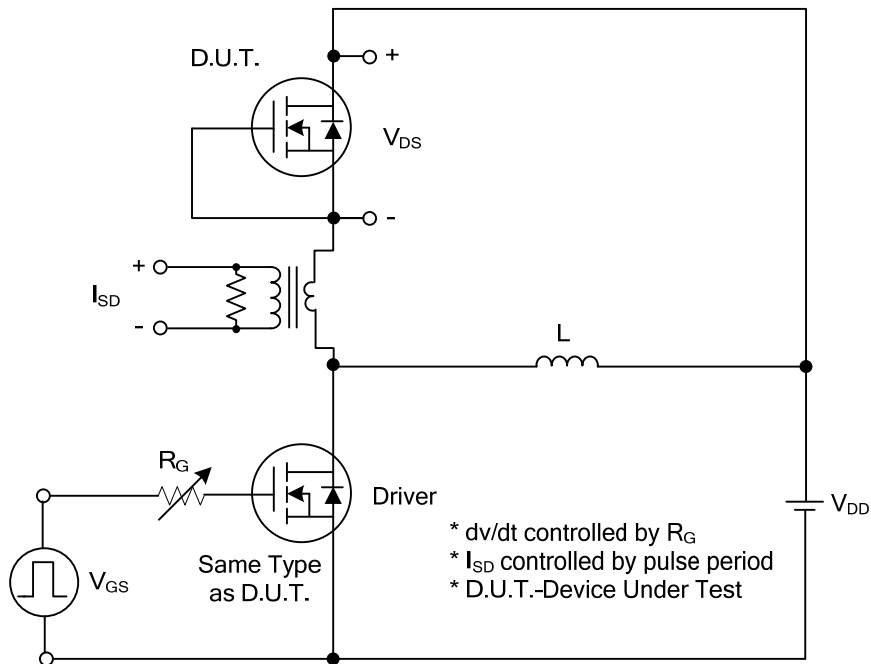

Peak Diode Recovery dv/dt Test Circuit

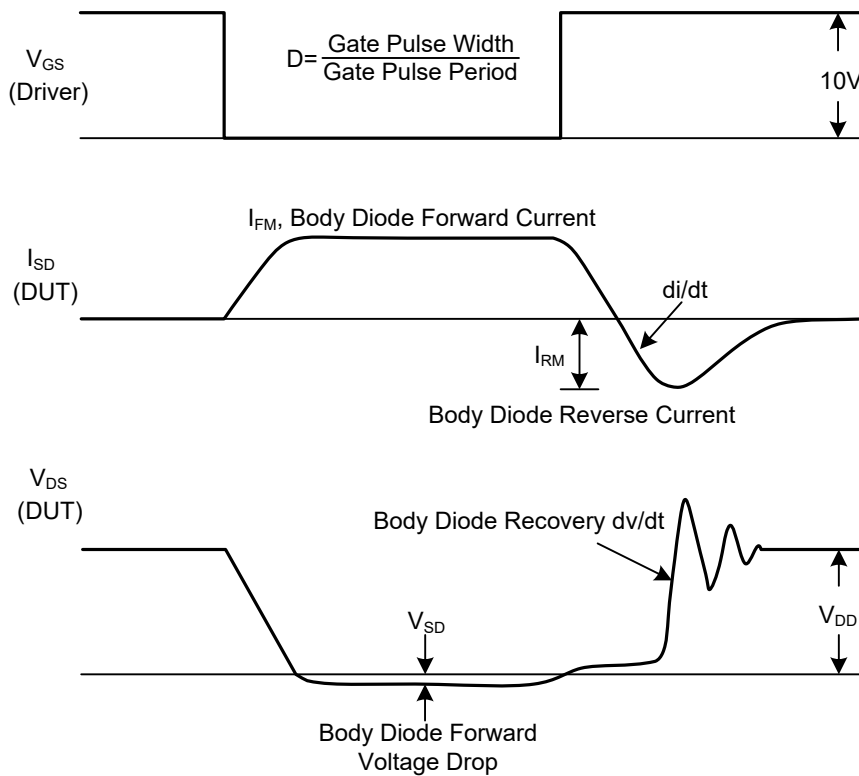

Peak Diode Recovery dv/dt Waveforms

■ TEST CIRCUITS AND WAVEFORMS

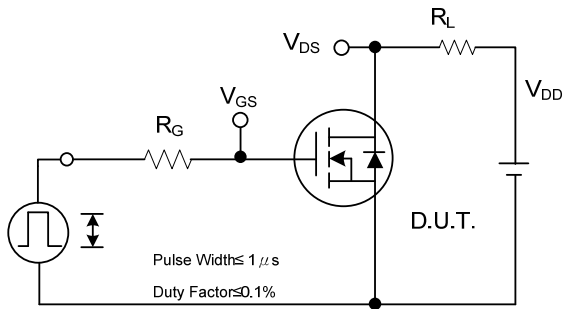

Switching Test Circuit

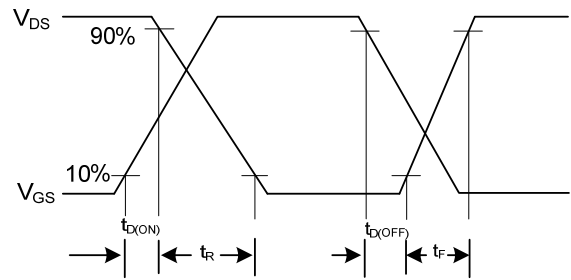

Switching Waveforms

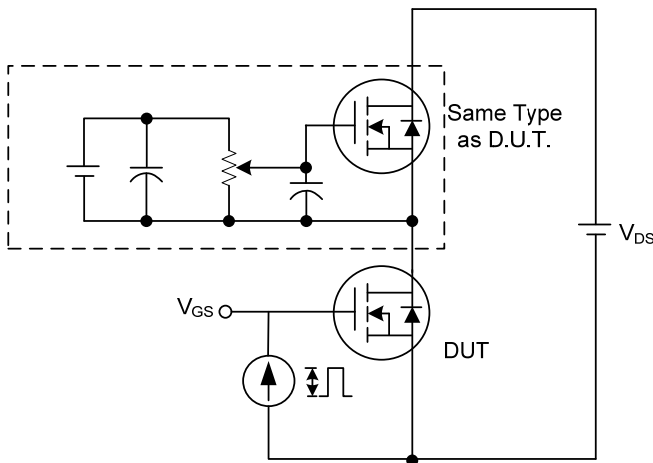

Gate Charge Test Circuit

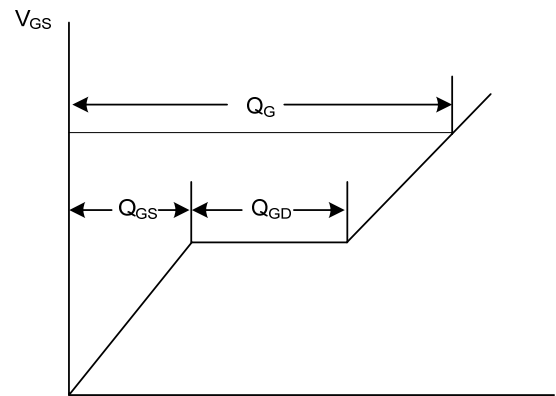

Charge  
Gate Charge Waveform

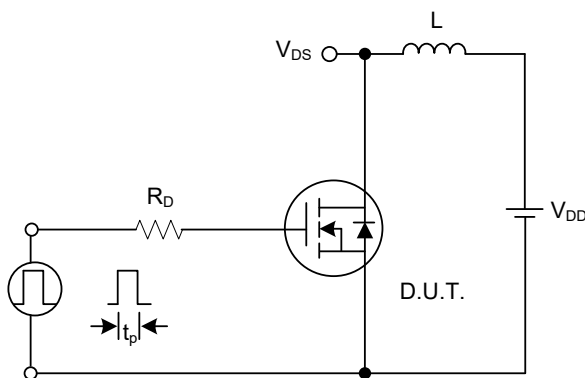

Unclamped Inductive Switching Test Circuit

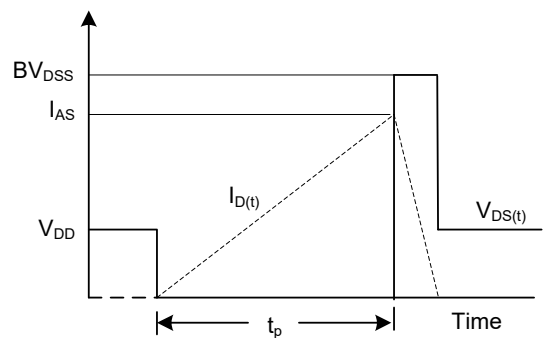

Unclamped Inductive Switching Waveforms

UTC assumes no responsibility for equipment failures that result from using products at values that exceed, even momentarily, rated values (such as maximum ratings, operating condition ranges, or other parameters) listed in products specifications of any and all UTC products described or contained herein. UTC products are not designed for use in life support appliances, devices or systems where malfunction of these products can be reasonably expected to result in personal injury. Reproduction in whole or in part is prohibited without the prior written consent of the copyright owner. UTC reserves the right to make changes to information published in this document, including without limitation specifications and product descriptions, at any time and without notice. This document supersedes and replaces all information supplied prior to the publication hereof.