

# 禁用RoHS / REACH/SS00259 之有害物質

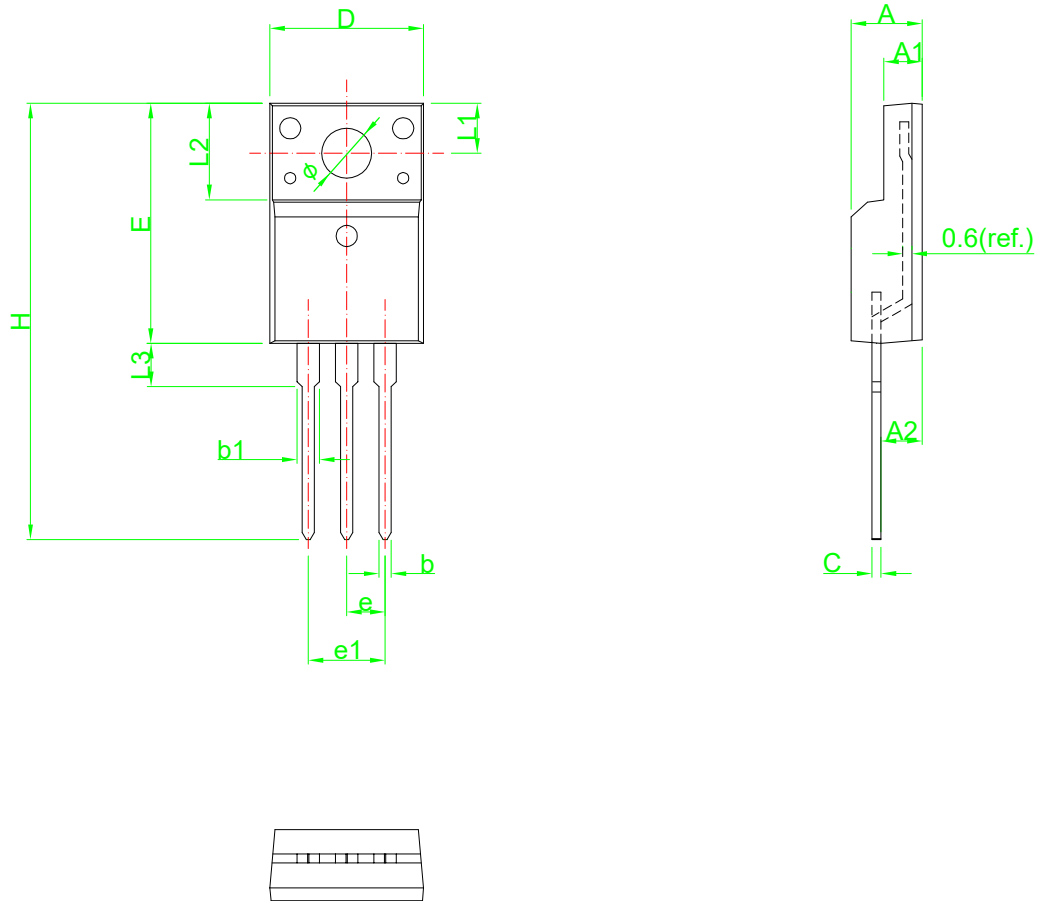

Symbol	Dimensions in Millimeters		Dimensions in Inches	
	Min	Max	Min	Max
A	4.40	5.00	0.173	0.197
A1	2.30	2.80	0.091	0.110
A2	2.45	3.05	0.096	0.120
b	0.60	1.00	0.024	0.039
b1	1.10	1.50	0.043	0.059
C	0.30	0.70	0.012	0.028
D	9.86	10.46	0.388	0.412
E	15.40	16.40	0.606	0.646
e	2.54TYP		0.100TYP	
H	28.20	29.40	1.110	1.157
L1	3.05	3.55	0.120	0.140
L2	6.40	7.00	0.252	0.276
L3	2.95	3.55	0.116	0.140
$\phi$	2.90	3.50	0.114	0.138



友順科技股份有限公司  
UNISONIC TECHNOLOGIES CO.,LTD

正式發行圖面

SCALE	mm
2: 發行	0 30
SHEET	THIRD ANGLE PROJECTION
1 of 1	Aug 20 2021
ENG. 文件管理	2021/8/16
APPR. UTC Doc Control Center	Joshua yang 2021/8/16

REV: A4  
PART NO: TO-220F1  
DWG NO: DIM-TO-220F1-000-A4

TITLE  
**TO-220F1**  
**Package Dimensions**