



DTNP143Z

DUAL TRANSISTOR

GENERAL PURPOSE (DUAL DIGITAL TRANSISTOR)

■ **FEATURES**

- * Both the DTA143Z chip and DTC143Z chip in a SOT-363 package.
- * NPN/PNP silicon transistor(Built-in resistor type)

■ **EQUIVALENT CIRCUIT**

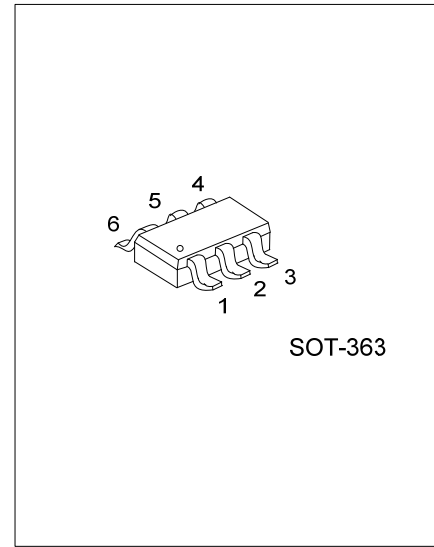
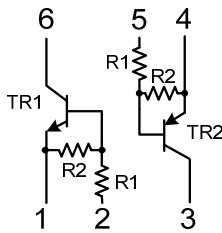

■ **ORDERING INFORMATION**

Ordering Number		Package	Pin Assignment						Packing
Lead Free	Halogen Free		1	2	3	4	5	6	
DTNP143ZL-AL6-R	DTNP143ZG-AL6-R	SOT-363	G1	I1	O2	G2	I2	O1	Tape Reel

Note: Pin Assignment: G: GND I: Input O: Output

<p>DTNP143ZG-AL6-R</p> <ul style="list-style-type: none"> (1)Packing Type (2)Package Type (3)Green Package 	<ul style="list-style-type: none"> (1) R: Tape Reel (2) AL6: SOT-363 (3) G: Halogen Free and Lead Free, L: Lead Free
---	---

■ **MARKING**

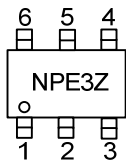

■ ABSOLUTE MAXIMUM RATINGS ($T_A=25^{\circ}\text{C}$, unless otherwise specified)

PARAMETER	SYMBOL	RATINGS		UNIT
		TR1 (NPN)	TR2 (PNP)	
Supply Voltage	V_{CC}	50	-50	V
Input Voltage	V_{IN}	-5 ~ +30	-30 ~ +5	V
Output Current	I_{OUT}	100	-100	mA
	$I_{C(MAX)}$	100	-100	mA
Total Power Dissipation (120mW per element must not be exceeded)	P_D	150		mW
Junction Temperature	T_J	+150		$^{\circ}\text{C}$
Storage Temperature	T_{STG}	-55 ~ +150		$^{\circ}\text{C}$

Note: Absolute maximum ratings are those values beyond which the device could be permanently damaged. Absolute maximum ratings are stress ratings only and functional device operation is not implied.

■ ELECTRICAL CHARACTERISTICS ($T_A=25^{\circ}\text{C}$, unless otherwise specified)

TR1 (NPN)

PARAMETER	SYMBOL	TEST CONDITIONS	MIN	TYP	MAX	UNIT
Input Voltage	$V_{IN(OFF)}$	$V_{CC}=5V, I_{OUT}=100\mu A$			0.5	V
	$V_{IN(ON)}$	$V_{OUT}=0.3V, I_{OUT}=5mA$	1.3			
Output Voltage	$V_{OUT(ON)}$	$I_{OUT}/I_{IN}=5mA/0.25mA$		0.1	0.3	V
Input Current	I_{IN}	$V_{IN}=5V$			1.8	mA
Output Current	$I_{O(OFF)}$	$V_{CC}=50V, V_{IN}=0V$			0.5	μA
DC Current Gain	h_{FE}	$V_{OUT}=5V, I_{OUT}=10mA$	80			
Input Resistance	R_1		3.29	4.7	6.11	k Ω
Resistance Ratio	R_2/R_1		8	10	12	
Transition Frequency	f_T	$V_{CE}=10V, I_E=-5mA, f=100MHz$ (Note)		250		MHz

Note: Transition Frequency of the Device.

TR2 (PNP)

PARAMETER	SYMBOL	TEST CONDITIONS	MIN	TYP	MAX	UNIT
Input Voltage	$V_{IN(OFF)}$	$V_{CC}=-5V, I_{OUT}=-100\mu A$			-0.5	V
	$V_{IN(ON)}$	$V_{OUT}=-0.3V, I_{OUT}=-5mA$	-1.3			
Output Voltage	$V_{OUT(ON)}$	$I_{OUT}/I_{IN}=-5mA/-0.25mA$		-0.1	-0.3	V
Input Current	I_{IN}	$V_{IN}=-5V$			-1.8	mA
Output Current	$I_{O(OFF)}$	$V_{CC}=-50V, V_{IN}=0V$			-0.5	μA
DC Current Gain	h_{FE}	$V_{OUT}=-5V, I_{OUT}=-10mA$	80			
Input Resistance	R_1		3.29	4.7	6.11	k Ω
Resistance Ratio	R_2/R_1		8	10	12	
Transition Frequency	f_T	$V_{CE}=-10V, I_E=-5mA, f=100MHz$ (Note)		250		MHz

Note: Transition Frequency of the Device.

■ TYPICAL CHARACTERISTICS

TR1 (NPN)

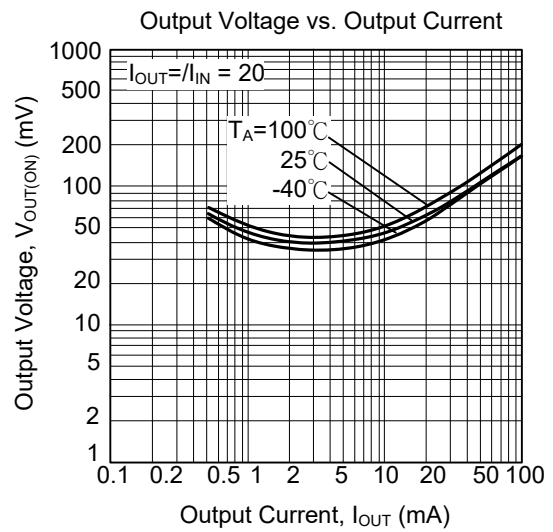
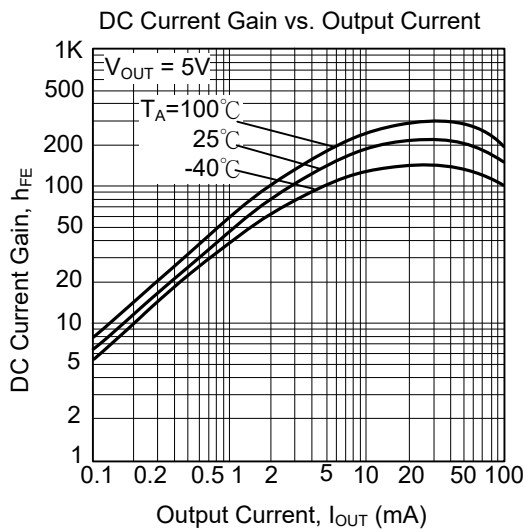
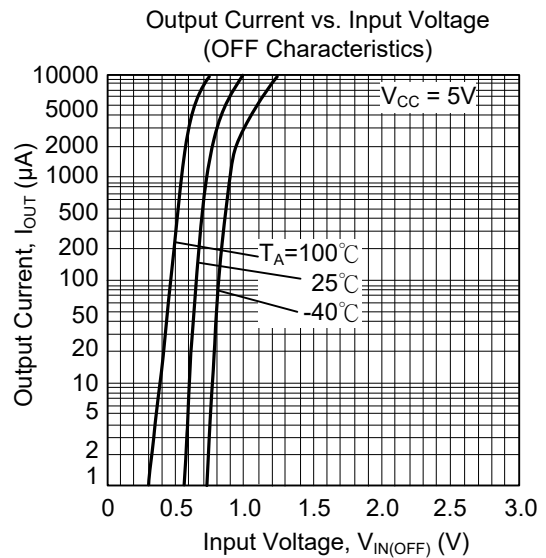
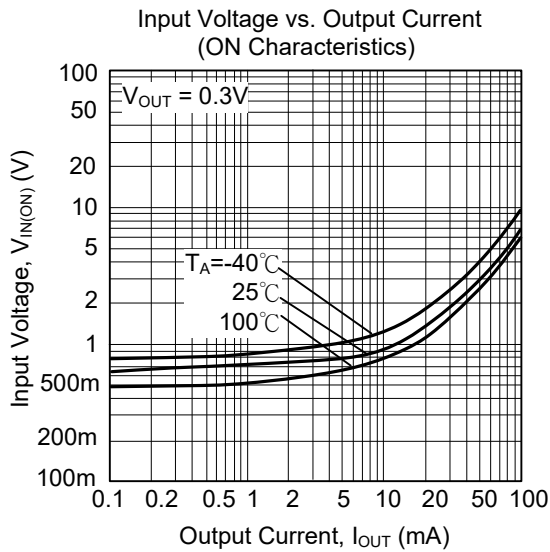

■ TYPICAL CHARACTERISTICS

TR2 (PNP)

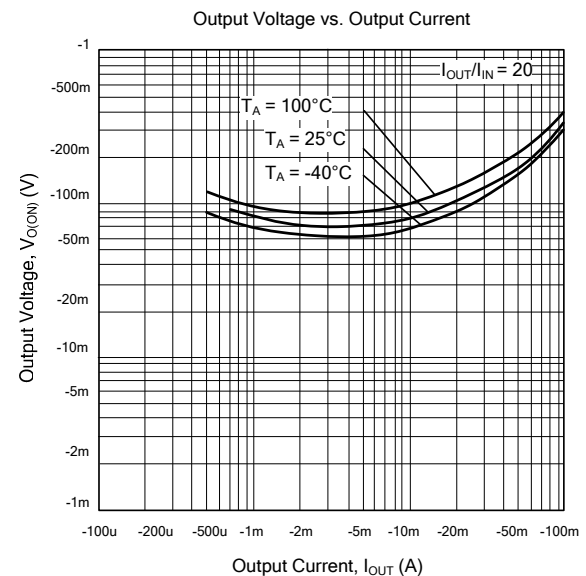
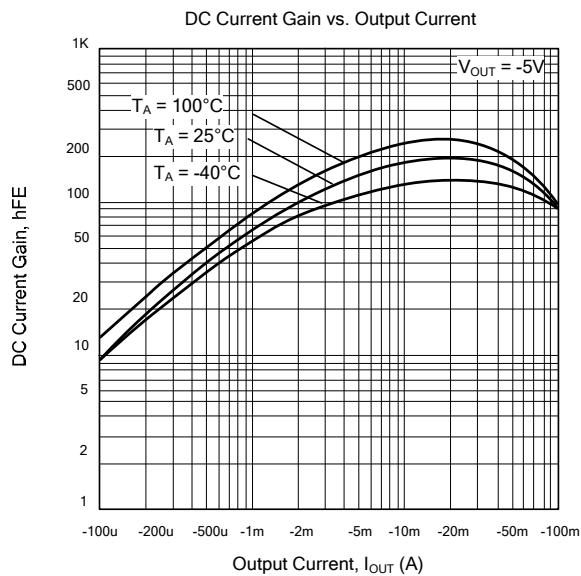
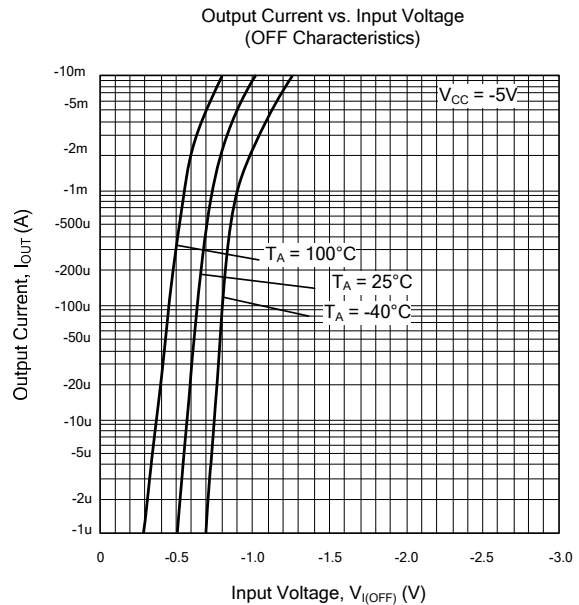
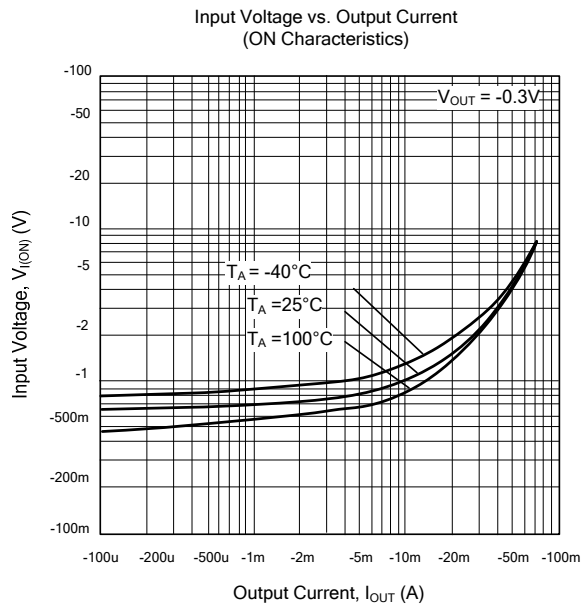

UTC assumes no responsibility for equipment failures that result from using products at values that exceed, even momentarily, rated values (such as maximum ratings, operating condition ranges, or other parameters) listed in products specifications of any and all UTC products described or contained herein. UTC products are not designed for use in life support appliances, devices or systems where malfunction of these products can be reasonably expected to result in personal injury. Reproduction in whole or in part is prohibited without the prior written consent of the copyright owner. UTC reserves the right to make changes to information published in this document, including without limitation specifications and product descriptions, at any time and without notice. This document supersedes and replaces all information supplied prior to the publication hereof.