



78MXXS

Preliminary

LINEAR INTEGRATED CIRCUIT

3-TERMINAL 0.5A POSITIVE VOLTAGE REGULATOR

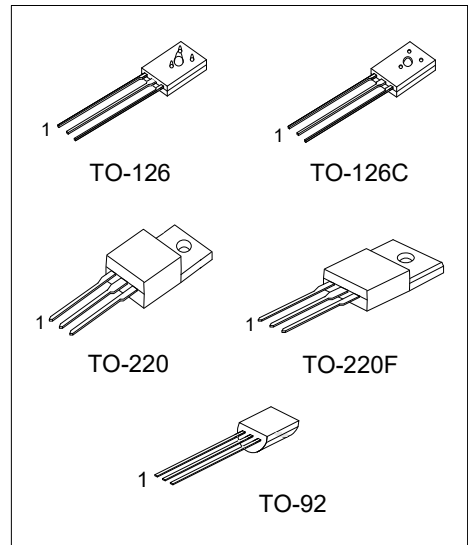

DESCRIPTION

The UTC **78MXXS** family is monolithic fixed voltage regulator integrated circuit. They are suitable for applications that required supply current up to 0.5A.

FEATURES

- * Output Current up to 0.5A
- * Fixed Output Voltage of 5V, 6V, 7V, 8V, 9V, 12V, 15V, 18V and 20V Available
- * Thermal Overload Shutdown Protection
- * Short Circuit Current Limiting
- * Output Transistor SOA Protection

ORDERING INFORMATION

Ordering Number		Package	Pin Assignment			Packing
Lead Free	Halogen Free		1	2	3	
78MXXSL-TA3-T	78MXXSG-TA3-T	TO-220	I	G	O	Tube
78MXXSL-TF3-T	78MXXSG-TF3-T	TO-220F	I	G	O	Tube
78MXXSL-T60-K	78MXXSG-T60-K	TO-126	I	G	O	Bulk
78MXXSL-T6C-K	78MXXSG-T6C-K	TO-126C	I	G	O	Bulk
78MXXSL-T92-B	78MXXSG-T92-B	TO-92	O	G	I	Tape Box
78MXXSL-T92-K	78MXXSG-T92-K	TO-92	O	G	I	Bulk

Notes: 1. xx: output voltage, refer to Marking Information

2. Pin Code: I: Input G: GND O: Output

<p>78MXXSG-TA3-T</p> <p>(1)Packing Type (2)Package Type (3)Green Package (4)Output Voltage</p>	<p>(1) T: Tube, B: Tape Box, K: Bulk (2) TA3: TO-220, TF3: TO-220F, T60: TO-126 T6C: TO-126C, T92: TO-92 (3) L: Lead Free, G: Halogen Free and Lead Free (4) xx: refer to Marking Information</p>
--	---

MARKING INFORMATION

PACKAGE	VOLTAGE CODE	MARKING
TO-220 TO-220F	05: 5V 06: 6V 07: 7V 08: 8V 09: 9V 12: 12V 15: 15V 18: 18V 20: 20V	<p>UTC 78MXXS</p> <p>Voltage Code ← → Date Code</p> <p>Lot Code ← →</p> <p>1 2 3</p> <p>L: Lead Free G: Halogen Free</p>
TO-126 TO-126C		<p>UTC</p> <p>78MXXS</p> <p>Voltage Code ← → Date Code</p> <p>1 2 3</p> <p>L: Lead Free G: Halogen Free</p>
TO-92		<p>UTC</p> <p>78MXXS</p> <p>Voltage Code ← → Date Code</p> <p>1 2 3</p> <p>L: Lead Free G: Halogen Free</p>

BLOCK DIAGRAM

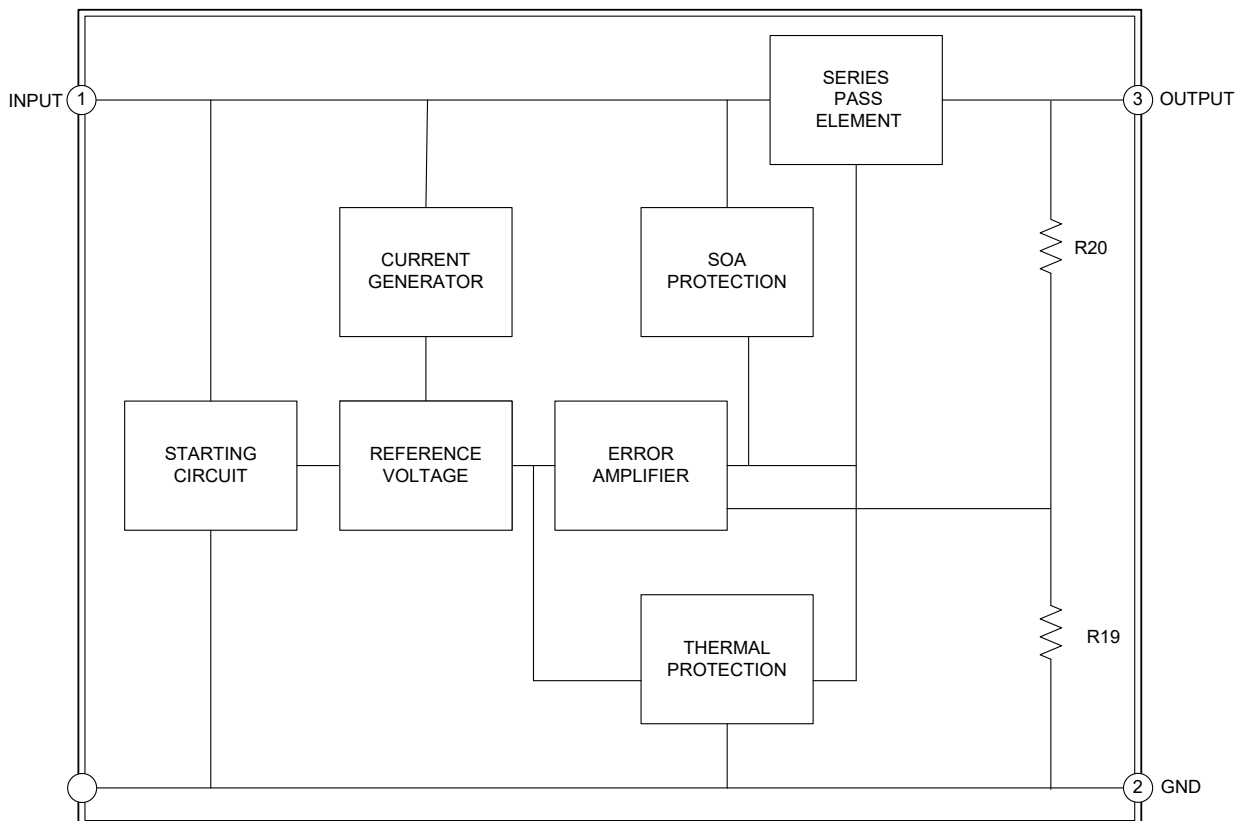

■ ABSOLUTE MAXIMUM RATINGS

(Operating temperature range applies unless otherwise specified)

PARAMETER		SYMBOL	RATING	UNIT
Input Voltage		V_{IN}	35	V
Output Current		I_{OUT}	0.5	A
Power Dissipation	TO-126/TO-126C	P_D	1.12	W
	TO-220/TO-220F		1.85	W
	TO-92		0.55	W
Junction Temperature		T_J	+150	°C
Operating Junction Temperature		T_{OPR}	-40 ~ +125	°C
Storage Temperature		T_{STG}	-65 ~ +150	°C

Note: Absolute maximum ratings are those values beyond which the device could be permanently damaged. Absolute maximum ratings are stress ratings only and functional device operation is not implied.

■ THERMAL DATA

PARAMETER		SYMBOL	RATINGS	UNIT
Junction to Ambient	TO-126/TO-126C	θ_{JA}	89	°C/W
	TO-220/TO-220F		54	°C/W
	TO-92		180	°C/W
Junction to Case	TO-126/TO-126C	θ_{JC}	12.5	°C/W
	TO-220/TO-220F		4	°C/W
	TO-92		83	°C/W

■ ELECTRICAL CHARACTERISTICS

For UTC78M05S

(Refer to the test circuits, $T_J=25^\circ\text{C}$, $I_{OUT}=350\text{mA}$, $V_{IN}=10\text{V}$, unless otherwise specified, $C_1=0.33\mu\text{F}$, $C_0=0.1\mu\text{F}$)

PARAMETER	SYMBOL	TEST CONDITIONS	MIN	TYP	MAX	UNIT
Output Voltage	V_{OUT}	$T_J=25^\circ\text{C}$	4.80	5.0	5.20	V
		$I_{OUT}=5\text{mA} \sim 350\text{mA}$, $V_{IN}=7 \sim 20\text{V}$	4.75		5.25	V
Load Regulation	ΔV_{OUT}	$T_J=25^\circ\text{C}$, $I_{OUT}=5\text{mA} \sim 0.5\text{A}$			100	mV
		$T_J=25^\circ\text{C}$, $I_{OUT}=5\text{mA} \sim 200\text{mA}$			50	mV
Line regulation	ΔV_{OUT}	$V_{IN}=7 \sim 25\text{V}$, $T_J=25^\circ\text{C}$, $I_{OUT}=200\text{mA}$			100	mV
		$V_{IN}=8 \sim 25\text{V}$, $T_J=25^\circ\text{C}$, $I_{OUT}=200\text{mA}$			50	mV
Quiescent Current	I_Q	$T_J=25^\circ\text{C}$		4.0	6.0	mA
Quiescent Current Change	ΔI_Q	$V_{IN}=8 \sim 25\text{V}$, $I_{OUT}=200\text{mA}$			0.8	mA
		$I_{OUT}=5\text{mA} \sim 350\text{mA}$			0.5	mA
Output Noise Voltage	eN	$10\text{Hz} \leq f \leq 100\text{KHz}$		40		μV
Ripple Rejection	RR	$V_{IN}=8 \sim 18\text{V}$, $f=120\text{Hz}$, $I_{OUT}=300\text{mA}$	62			dB
Peak Output Current	I_{PEAK}	$T_J=25^\circ\text{C}$		700		mA
Short-Circuit Current	I_{SC}	$V_{IN}=V_{OUT}+19\text{V}$, $T_J=25^\circ\text{C}$		300		mA
Dropout Voltage	V_D	$T_J=25^\circ\text{C}$, $I_{OUT}=500\text{mA}$		2.0		V

■ ELECTRICAL CHARACTERISTICS (Cont.)

For UTC78M07S

(Refer to the test circuits, $T_J=25^\circ\text{C}$, $I_{OUT}=350\text{mA}$, $V_{IN}=13\text{V}$, unless otherwise specified, $C_I=0.33\mu\text{F}$, $C_O=0.1\mu\text{F}$)

PARAMETER	SYMBOL	TEST CONDITIONS	MIN	TYP	MAX	UNIT
Output Voltage	V_{OUT}	$T_J=25^\circ\text{C}$	6.72	7.0	7.28	V
		$V_{IN}=9.5\text{V} \sim 22\text{V}$, $I_{OUT}=5\text{mA} \sim 350\text{mA}$	6.65		7.35	V
Load Regulation	ΔV_{OUT}	$T_J=25^\circ\text{C}$, $I_{OUT}=5\text{mA} \sim 0.5\text{A}$			140	mV
		$T_J=25^\circ\text{C}$, $I_{OUT}=5\text{mA} \sim 200\text{mA}$			70	mV
Line regulation	ΔV_{OUT}	$V_{IN}=9.5\text{V} \sim 22\text{V}$, $T_J=25^\circ\text{C}$, $I_{OUT}=200\text{mA}$			100	mV
		$V_{IN}=9.5\text{V} \sim 22\text{V}$, $T_J=25^\circ\text{C}$, $I_{OUT}=200\text{mA}$			50	mV
Quiescent Current	I_Q	$T_J=25^\circ\text{C}$		4.0	6	mA
Quiescent Current Change	ΔI_Q	$V_{IN}=10.5\text{V} \sim 22\text{V}$, $I_{OUT}=200\text{mA}$			0.8	mA
		$I_{OUT}=5\text{mA} \sim 350\text{mA}$			0.5	mA
Output Noise Voltage	eN	$10\text{Hz} \leq f \leq 100\text{KHz}$		49		μV
Ripple Rejection	RR	$V_{IN}=11.5\text{V} \sim 21.5\text{V}$, $f=120\text{Hz}$, $I_{OUT}=300\text{mA}$	57			dB
Peak Output Current	I_{PEAK}	$T_J=25^\circ\text{C}$		700		mA
Short-Circuit Current	I_{SC}	$V_{IN}=V_{OUT}+19\text{V}$, $T_J=25^\circ\text{C}$		300		mA
Dropout Voltage	V_D	$T_J=25^\circ\text{C}$, $I_{OUT}=500\text{mA}$		2.0		V

For UTC78M06S

(Refer to the test circuits, $T_J=25^\circ\text{C}$, $I_{OUT}=350\text{mA}$, $V_{IN}=11\text{V}$, unless otherwise specified, $C_I=0.33\mu\text{F}$, $C_O=0.1\mu\text{F}$)

PARAMETER	SYMBOL	TEST CONDITIONS	MIN	TYP	MAX	UNIT
Output Voltage	V_{OUT}	$T_J=25^\circ\text{C}$, $I_{OUT}=5 \sim 350\text{mA}$	5.76	6.0	6.24	V
		$V_{IN}=8 \sim 21\text{V}$, $I_{OUT}=5\text{mA} \sim 350\text{mA}$	5.70		6.30	V
Load Regulation	ΔV_{OUT}	$T_J=25^\circ\text{C}$, $I_{OUT}=5\text{mA} \sim 0.5\text{A}$			120	mV
		$T_J=25^\circ\text{C}$, $I_{OUT}=5\text{mA} \sim 200\text{mA}$			60	mV
Line regulation	ΔV_{OUT}	$V_{IN}=8\text{V} \sim 25\text{V}$, $T_J=25^\circ\text{C}$, $I_{OUT}=200\text{mA}$			100	mV
		$V_{IN}=9\text{V} \sim 25\text{V}$, $T_J=25^\circ\text{C}$, $I_{OUT}=200\text{mA}$			50	mV
Quiescent Current	I_Q	$T_J=25^\circ\text{C}$		4.0	6	mA
Quiescent Current Change	ΔI_Q	$I_{OUT}=5\text{mA} \sim 350\text{mA}$			0.8	mA
		$V_{IN}=9\text{V} \sim 25\text{V}$, $I_{OUT}=200\text{mA}$			0.5	mA
Output Noise Voltage	eN	$10\text{Hz} \leq f \leq 100\text{kHz}$		45		μV
Ripple Rejection	RR	$V_{IN}=9\text{V} \sim 19\text{V}$, $f=120\text{Hz}$, $T_J=25^\circ\text{C}$ $I_{OUT}=300\text{mA}$	59			dB
Peak Output Current	I_{PEAK}	$T_J=25^\circ\text{C}$		700		mA
Short-Circuit Current	I_{SC}	$V_{IN}=V_{OUT}+19\text{V}$, $T_J=25^\circ\text{C}$		300		mA
Dropout Voltage	V_D	$T_J=25^\circ\text{C}$		2.0		V

■ ELECTRICAL CHARACTERISTICS (Cont.)

For UTC78M08S

(Refer to the test circuits, $T_J=25^\circ\text{C}$, $I_{OUT}=350\text{mA}$, $V_{IN}=14\text{V}$, unless otherwise specified, $C_I=0.33\mu\text{F}$, $C_O=0.1\mu\text{F}$)

PARAMETER	SYMBOL	TEST CONDITIONS	MIN	TYP	MAX	UNIT
Output Voltage	V_{OUT}	$T_J=25^\circ\text{C}$	7.68	8.0	8.32	V
		$V_{IN}=10.5\text{V} \sim 23\text{V}$, $I_{OUT}=5\text{mA} \sim 350\text{mA}$	7.60		8.40	V
Load Regulation	ΔV_{OUT}	$T_J=25^\circ\text{C}$, $I_{OUT}=5\text{mA} \sim 0.5\text{A}$			160	mV
		$T_J=25^\circ\text{C}$, $I_{OUT}=5\text{mA} \sim 200\text{mA}$			80	mV
Line regulation	ΔV_{OUT}	$V_{IN}=10.5\text{V} \sim 25\text{V}$, $T_J=25^\circ\text{C}$, $I_{OUT}=200\text{mA}$			100	mV
		$V_{IN}=11\text{V} \sim 25\text{V}$, $T_J=25^\circ\text{C}$, $I_{OUT}=200\text{mA}$			50	mV
Quiescent Current	I_Q	$T_J=25^\circ\text{C}$		4.0	6	mA
Quiescent Current Change	ΔI_Q	$V_{IN}=10.5\text{V} \sim 25\text{V}$, $I_{OUT}=200\text{mA}$			0.8	mA
		$I_{OUT}=5\text{mA} \sim 350\text{mA}$			0.5	mA
Output Noise Voltage	eN	$10\text{Hz} \leq f \leq 100\text{KHz}$		52		μV
Ripple Rejection	RR	$V_{IN}=11.5\text{V} \sim 21.5\text{V}$, $f=120\text{Hz}$, $I_{OUT}=300\text{mA}$	56			dB
Peak Output Current	I_{PEAK}	$T_J=25^\circ\text{C}$		700		mA
Short-Circuit Current	I_{SC}	$V_{IN}=V_{OUT}+19\text{V}$, $T_J=25^\circ\text{C}$		300		mA
Dropout Voltage	V_D	$T_J=25^\circ\text{C}$, $I_{OUT}=500\text{mA}$		2.0		V

For UTC78M09S

(Refer to the test circuits, $T_J=25^\circ\text{C}$, $I_{OUT}=350\text{mA}$, $V_{IN}=17\text{V}$, unless otherwise specified, $C_I=0.33\mu\text{F}$, $C_O=0.1\mu\text{F}$)

PARAMETER	SYMBOL	TEST CONDITIONS	MIN	TYP	MAX	UNIT
Output Voltage	V_{OUT}	$T_J=25^\circ\text{C}$	8.64	9	9.36	V
		$V_{IN}=12.5\text{V} \sim 25\text{V}$, $I_{OUT}=5\text{mA} \sim 350\text{mA}$	8.55		9.45	V
Load Regulation	ΔV_{OUT}	$T_J=25^\circ\text{C}$, $I_{OUT}=5\text{mA} \sim 0.5\text{A}$			200	mV
		$T_J=25^\circ\text{C}$, $I_{OUT}=5\text{mA} \sim 200\text{mA}$			100	mV
Line regulation	ΔV_{OUT}	$V_{IN}=12.5\text{V} \sim 25\text{V}$, $T_J=25^\circ\text{C}$, $I_{OUT}=200\text{mA}$			100	mV
		$V_{IN}=13\text{V} \sim 25\text{V}$, $T_J=25^\circ\text{C}$, $I_{OUT}=200\text{mA}$			50	mV
Quiescent Current	I_Q	$T_J=25^\circ\text{C}$		4.1	6	mA
Quiescent Current Change	ΔI_Q	$V_{IN}=12.5\text{V} \sim 25\text{V}$, $I_{OUT}=200\text{mA}$			0.8	mA
		$I_{OUT}=5\text{mA} \sim 350\text{mA}$			0.5	mA
Output Noise Voltage	eN	$10\text{Hz} \leq f \leq 100\text{KHz}$		65		μV
Ripple Rejection	RR	$V_{IN}=13\text{V} \sim 23\text{V}$, $f=120\text{Hz}$, $I_{OUT}=300\text{mA}$	55			dB
Peak Output Current	I_{PEAK}	$T_J=25^\circ\text{C}$		700		mA
Short-Circuit Current	I_{SC}	$V_{IN}=V_{OUT}+19\text{V}$, $T_J=25^\circ\text{C}$		300		mA
Dropout Voltage	V_D	$T_J=25^\circ\text{C}$, $I_{OUT}=500\text{mA}$		2.0		V

■ ELECTRICAL CHARACTERISTICS (Cont.)

For UTC78M12S

(Refer to the test circuits, $T_J=25^\circ\text{C}$, $I_{OUT}=350\text{mA}$, $V_{IN}=19\text{V}$, unless otherwise specified, $C_I=0.33\mu\text{F}$, $C_O=0.1\mu\text{F}$)

PARAMETER	SYMBOL	TEST CONDITIONS	MIN	TYP	MAX	UNIT
Output Voltage	V_{OUT}	$T_J=25^\circ\text{C}$	11.52	12.0	12.48	V
		$V_{IN}=14.5\text{V to }27\text{V}$, $I_{OUT}=5\text{mA}\sim 350\text{mA}$	11.40		12.60	V
Load Regulation	ΔV_{OUT}	$T_J=25^\circ\text{C}$, $I_{OUT}=5\text{mA}\sim 0.5\text{A}$			240	mV
		$T_J=25^\circ\text{C}$, $I_{OUT}=5\text{mA}\sim 2\text{A}$			120	mV
Line regulation	ΔV_{OUT}	$V_{IN}=14.5\text{V to }30\text{V}$, $T_J=25^\circ\text{C}$, $I_{OUT}=200\text{mA}$			100	mV
		$V_{IN}=16\text{V to }30\text{V}$, $T_J=25^\circ\text{C}$, $I_{OUT}=200\text{mA}$			50	mV
Quiescent Current	I_Q	$T_J=25^\circ\text{C}$		4.1	6.0	mA
Quiescent Current Change	ΔI_Q	$V_{IN}=14.5\text{V to }30\text{V}$, $I_{OUT}=200\text{mA}$			0.8	mA
		$I_{OUT}=5\text{mA}\sim 350\text{mA}$			0.5	mA
Output Noise Voltage	eN	$10\text{Hz}\leq f\leq 100\text{kHz}$		75		μV
Ripple Rejection	RR	$V_{IN}=15\text{V to }25\text{V}$, $f=120\text{Hz}$, $I_{OUT}=300\text{mA}$	55			dB
Peak Output Current	I_{PEAK}	$T_J=25^\circ\text{C}$		700		mA
Short-Circuit Current	I_{SC}	$V_{IN}=V_{OUT}+19\text{V}$, $T_J=25^\circ\text{C}$		300		mA
Dropout Voltage	V_D	$T_J=25^\circ\text{C}$, $I_{OUT}=500\text{mA}$		2.0		V

For UTC78M15S

(Refer to the test circuits, $T_J=25^\circ\text{C}$, $I_{OUT}=350\text{mA}$, $V_{IN}=23\text{V}$, unless otherwise specified, $C_I=0.33\mu\text{F}$, $C_O=0.1\mu\text{F}$)

PARAMETER	SYMBOL	TEST CONDITIONS	MIN	TYP	MAX	UNIT
Output Voltage	V_{OUT}	$T_J=25^\circ\text{C}$	14.40	15.0	15.60	V
		$V_{IN}=17.5\text{V} \sim 30\text{V}$, $I_{OUT}=5\text{mA}\sim 350\text{mA}$	14.25		15.75	V
Load Regulation	ΔV_{OUT}	$T_J=25^\circ\text{C}$, $I_{OUT}=5\text{mA}\sim 0.5\text{A}$			300	mV
		$T_J=25^\circ\text{C}$, $I_{OUT}=5\text{mA}\sim 200\text{mA}$			150	mV
Line regulation	ΔV_{OUT}	$V_{IN}=17.5\text{V} \sim 30\text{V}$, $T_J=25^\circ\text{C}$, $I_{OUT}=200\text{mA}$			100	mV
		$V_{IN}=20\text{V} \sim 30\text{V}$, $T_J=25^\circ\text{C}$, $I_{OUT}=200\text{mA}$			50	mV
Quiescent Current	I_Q	$T_J=25^\circ\text{C}$		4.1	6.0	mA
Quiescent Current Change	ΔI_Q	$V_{IN}=17.5\text{V} \sim 30\text{V}$, $I_{OUT}=200\text{mA}$			0.8	mA
		$I_{OUT}=5\text{mA}\sim 350\text{mA}$			0.5	mA
Output Noise Voltage	eN	$10\text{Hz}\leq f\leq 100\text{kHz}$		90		μV
Ripple Rejection	RR	$V_{IN}=18.5\text{V} \sim 28.5\text{V}$, $f=120\text{Hz}$, $I_{OUT}=300\text{mA}$	54			dB
Peak Output Current	I_{PEAK}	$T_J=25^\circ\text{C}$		700		mA
Short-Circuit Current	I_{SC}	$V_{IN}=V_{OUT}+19\text{V}$, $T_J=25^\circ\text{C}$		300		mA
Dropout Voltage	V_D	$T_J=25^\circ\text{C}$, $I_{OUT}=500\text{mA}$		2.0		V

■ ELECTRICAL CHARACTERISTICS (Cont.)

For 78M18S

(Refer to the test circuits, $T_J=25^\circ\text{C}$, $I_{OUT}=350\text{mA}$, $V_{IN}=26\text{V}$, unless otherwise specified, $C_I=0.33\mu\text{F}$, $C_O=0.1\mu\text{F}$)

PARAMETER	SYMBOL	TEST CONDITIONS	MIN	TYP	MAX	UNIT
Output Voltage	V_{OUT}	$T_J=25^\circ\text{C}$	17.28	18.0	18.72	V
		$V_{IN}=20.5\text{V} \sim 33\text{V}$ $I_{OUT}=5\text{mA} \sim 350\text{mA}$	17.10		18.90	V
Load Regulation	ΔV_{OUT}	$T_J=25^\circ\text{C}$, $I_{OUT}=5\text{mA} \sim 0.5\text{A}$			360	mV
		$T_J=25^\circ\text{C}$, $I_{OUT}=5\text{mA} \sim 200\text{mA}$			180	mV
Line regulation	ΔV_{OUT}	$V_{IN}=21\text{V} \sim 33\text{V}$ $T_J=25^\circ\text{C}$, $I_{OUT}=200\text{mA}$			100	mV
		$V_{IN}=24\text{V} \sim 33\text{V}$, $T_J=25^\circ\text{C}$, $I_{OUT}=200\text{mA}$			50	mV
Quiescent Current	I_Q	$T_J=25^\circ\text{C}$		4.2	6	mA
Quiescent Current Change	ΔI_Q	$V_{IN}=21\text{V} \sim 33\text{V}$, $I_{OUT}=200\text{mA}$			0.8	mA
		$I_{OUT}=5\text{mA} \sim 350\text{mA}$			0.5	mA
Output Noise Voltage	eN	$10\text{Hz} \leq f \leq 100\text{KHz}$		100		μV
Ripple Rejection	RR	$V_{IN}=22\text{V} \sim 32\text{V}$, $f=120\text{Hz}$ $I_{OUT}=300\text{mA}$	53			dB
Peak Output Current	I_{PEAK}	$T_J=25^\circ\text{C}$		700		mA
Short-Circuit Current	I_{SC}	$V_{IN}=35\text{V}$, $T_J=25^\circ\text{C}$		300		mA
Dropout Voltage	V_D	$T_J=25^\circ\text{C}$		2.0		V

For 78M20S

(Refer to the test circuits, $T_J=25^\circ\text{C}$, $I_{OUT}=350\text{mA}$, $V_{IN}=29\text{V}$, unless otherwise specified, $C_I=0.33\mu\text{F}$, $C_O=0.1\mu\text{F}$)

PARAMETER	SYMBOL	TEST CONDITIONS	MIN	TYP	MAX	UNIT
Output Voltage	V_{OUT}	$T_J=25^\circ\text{C}$	19.20	20.0	20.80	V
		$V_{IN}=23\text{V} \sim 35\text{V}$ $I_{OUT}=5\text{mA} \sim 350\text{mA}$	19		21	V
Load Regulation	ΔV_{OUT}	$T_J=25^\circ\text{C}$, $I_{OUT}=5\text{mA} \sim 0.5\text{A}$			400	mV
		$T_J=25^\circ\text{C}$, $I_{OUT}=5\text{mA} \sim 200\text{mA}$			200	mV
Line regulation	ΔV_{OUT}	$V_{IN}=23\text{V} \sim 35\text{V}$ $T_J=25^\circ\text{C}$, $I_{OUT}=200\text{mA}$			100	mV
		$V_{IN}=24\text{V} \sim 35\text{V}$, $T_J=25^\circ\text{C}$, $I_{OUT}=200\text{mA}$			50	mV
Quiescent Current	I_Q	$T_J=25^\circ\text{C}$		4	6	mA
Quiescent Current Change	ΔI_Q	$V_{IN}=23.5\text{V} \sim 35\text{V}$, $I_{OUT}=200\text{mA}$			0.8	mA
		$I_{OUT}=5\text{mA} \sim 350\text{mA}$			0.5	mA
Output Noise Voltage	eN	$10\text{Hz} \leq f \leq 100\text{KHz}$		105		μV
Ripple Rejection	RR	$V_{IN}=24\text{V} \sim 34\text{V}$, $f=120\text{Hz}$ $I_{OUT}=300\text{mA}$	52			dB
Peak Output Current	I_{PEAK}	$T_J=25^\circ\text{C}$		700		mA
Short-Circuit Current	I_{SC}	$V_{IN}=35\text{V}$, $T_J=25^\circ\text{C}$		300		mA
Dropout Voltage	V_D	$T_J=25^\circ\text{C}$		2.0		V

Notes: 1. The Maximum steady state usable output current is dependent on input voltage, heat sinking, lead length of the package and copper pattern of PCB. The data above represents pulse test conditions with junction temperatures specified at the initiation of test.

2. Power dissipation $< 0.5\text{W}$

■ APPLICATION CIRCUIT

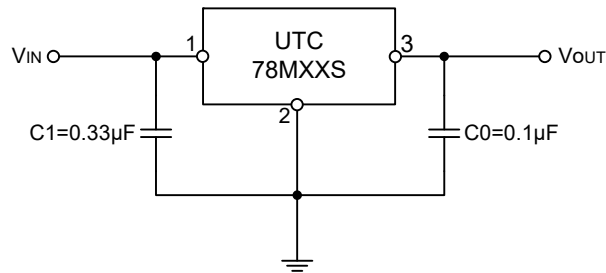

- Notes:
1. To specify an output voltage, substitute voltage value for "MXX".
 2. Bypass capacitors are recommended for optimum stability and transient response and should be located as close as possible to the regulators.

UTC assumes no responsibility for equipment failures that result from using products at values that exceed, even momentarily, rated values (such as maximum ratings, operating condition ranges, or other parameters) listed in products specifications of any and all UTC products described or contained herein. UTC products are not designed for use in life support appliances, devices or systems where malfunction of these products can be reasonably expected to result in personal injury. Reproduction in whole or in part is prohibited without the prior written consent of the copyright owner. UTC reserves the right to make changes to information published in this document, including without limitation specifications and product descriptions, at any time and without notice. This document supersedes and replaces all information supplied prior to the publication hereof.