



## 79DXXAS

## LINEAR INTEGRATED CIRCUIT

### 3 TERMINAL 1A NEGATIVE VOLTAGE REGULATOR

#### DESCRIPTION

The UTC **79DXXAS** series of three-terminal negative regulators is available several fixed output voltage, making them useful in a wide range of application. Each type employs internal current limiting, thermal shut-down, making it essentially indestructible.

#### FEATURES

- \* Output current up to 1A
- \* -5V, -6V, -7V, -8V, -9V, -12V, -15V, -18V, -24V output voltage available
- \* Thermal overload protection

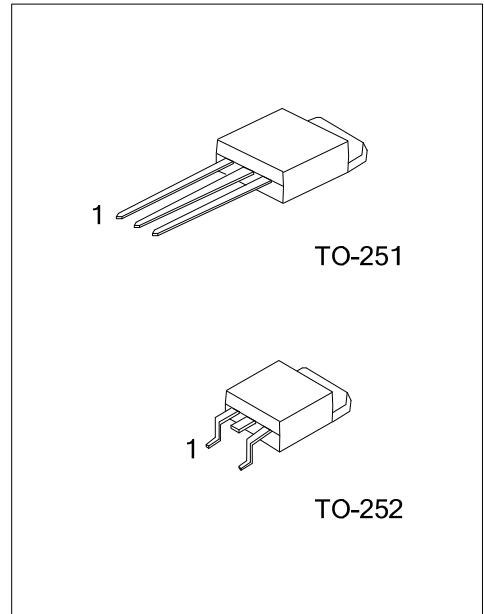

#### NORDERING INFORMATIO

Ordering Number		Package	Pin Assignment			Packing
Lead Free	Halogen Free		1	2	3	
79DXXASL-TM3-T	79DXXASG-TM3-T	TO-251	G	I	O	Tube
79DXXASL-TN3-T	79DXXASG-TN3-T	TO-252	G	I	O	Tube
79DXXASL-TN3-R	79DXXASG-TN3-R	TO-252	G	I	O	Tape Reel

Note: Pin Assignment: G: GND I: Input O: Output

<p>79DXXASG-TM3-T</p>	<p>(1)Packing Type (2)Package Type (3)Green Package (4)Output Voltage Code</p>	<p>(1) T: Tube, R: Tape Reel (2) TM3: TO-251, TN3: TO-252, (3) G: Halogen Free and Lead Free, L: Lead Free (4) XX: refer to Marking Information</p>
-----------------------	--	---

### MARKING INFORMATION

PACKAGE	VOLTAGE CODE	MARKING
TO-251 TO-252	05:-5V	
	06:-6V	
	07:-7V	
	08:-8V	
	09:-9V	
	12:-12V	
	15:-15V	
	18:-18V	
24:-24V		

### BLOCK DIAGRAM

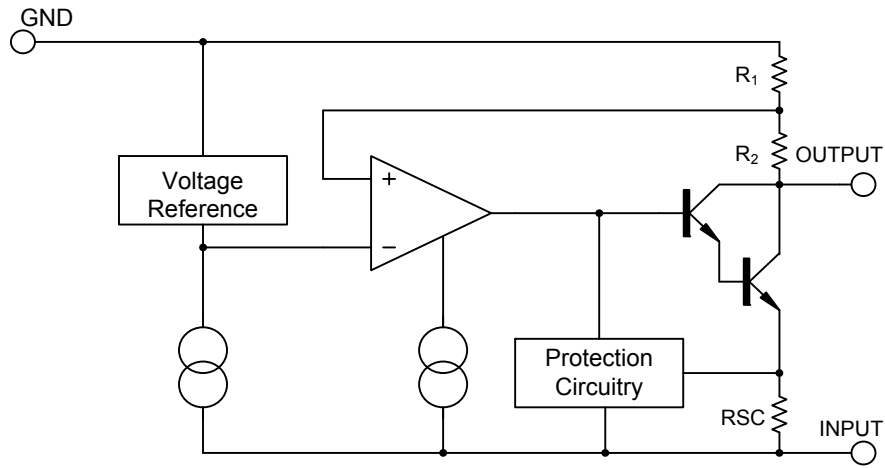

■ ABSOLUTE MAXIMUM RATINGS ( $T_A=25^{\circ}\text{C}$ , unless otherwise specified)

PARAMETER	SYMBOL	RATING	UNIT
Input Voltage	$V_{IN}$	-35	V
Output Current	$I_{OUT}$	1	A
Power Dissipation	$P_D$	0.89	W
Operating Temperature	$T_{OPR}$	-40 ~ +125	$^{\circ}\text{C}$
Storage Temperature	$T_{STG}$	-65 ~ +150	$^{\circ}\text{C}$

Note: Absolute maximum ratings are those values beyond which the device could be permanently damaged.

Absolute maximum ratings are stress ratings only and functional device operation is not implied.

■ THERMAL DATA

PARAMETER	SYMBOL	RATING	UNIT
Junction to Ambient	$\theta_{JA}$	112	$^{\circ}\text{C}/\text{W}$
Junction to Case	$\theta_{JC}$	12.5	$^{\circ}\text{C}/\text{W}$

■ ELECTRICAL CHARACTERISTICS

( $I_{OUT}=0.5\text{A}$ ,  $T_J=0^{\circ}\text{C}\sim 125^{\circ}\text{C}$ ,  $C_I=2.2\mu\text{F}$ ,  $C_O=1\mu\text{F}$ , unless otherwise specified)

For UTC 79D05AS ( $V_{IN}=-10\text{V}$ )

PARAMETER	SYMBOL	TEST CONDITIONS	MIN	TYP	MAX	UNIT
Output Voltage	$V_{OUT}$	$T_J=25^{\circ}\text{C}$	-4.80	-5.0	-5.20	V
		$V_{IN}=-7\text{V}\sim -20\text{V}$ , $I_{OUT}=5\text{mA}\sim 1\text{A}$	-4.75		-5.25	V
Dropout Voltage	$V_D$	$I_{OUT}=1\text{A}$ , $T_J=25^{\circ}\text{C}$		2		V
Line Regulation	$\Delta V_{OUT}$	$V_{IN}=-7\text{V}\sim -25\text{V}$ , $T_J=25^{\circ}\text{C}$		10	100	mV
		$V_{IN}=-8\text{V}\sim -12\text{V}$ , $T_J=25^{\circ}\text{C}$		5	60	mV
Load Regulation	$\Delta V_{OUT}$	$I_{OUT}=5\text{mA}\sim 1\text{A}$ , $T_J=25^{\circ}\text{C}$		10	100	mV
		$I_{OUT}=250\text{mA}\sim 750\text{mA}$ , $T_J=25^{\circ}\text{C}$		3	50	mV
Quiescent Current	$I_Q$	$T_J=25^{\circ}\text{C}$		3	6	mA
Quiescent Current Change	$\Delta I_Q$	$I_{OUT}=5\text{mA}\sim 1\text{A}$		0.05	0.5	mA
		$V_{IN}=-7\text{V}\sim -25\text{V}$		0.1	1.3	mA
Output Noise Voltage	eN	$f=10\text{Hz}\sim 100\text{kHz}$ , $T_A=25^{\circ}\text{C}$		100		$\mu\text{V}$
Output Voltage Drift	$\Delta V_{OUT}/\Delta T$	$I_{OUT}=5\text{mA}$		-0.4		$\text{mV}/^{\circ}\text{C}$
Peak Current	$I_{PEAK}$	$T_J=25^{\circ}\text{C}$		2.2		A

For UTC 79D06AS ( $V_{IN}=-11\text{V}$ )

PARAMETER	SYMBOL	TEST CONDITIONS	MIN	TYP	MAX	UNIT
Output Voltage	$V_{OUT}$	$T_J=25^{\circ}\text{C}$	-5.76	-6.00	-6.24	V
		$V_{IN}=-8\text{V}\sim -21\text{V}$ , $I_{OUT}=5\text{mA}\sim 1\text{A}$	-5.70		-6.30	V
Dropout Voltage	$V_D$	$I_{OUT}=1.0\text{A}$ , $T_J=25^{\circ}\text{C}$		2		V
Line Regulation	$\Delta V_{OUT}$	$V_{IN}=-8\text{V}\sim -25\text{V}$ , $T_J=25^{\circ}\text{C}$		10	120	mV
		$V_{IN}=-9\text{V}\sim -13\text{V}$ , $T_J=25^{\circ}\text{C}$		5	60	mV
Load Regulation	$\Delta V_{OUT}$	$I_{OUT}=5\text{mA}\sim 1\text{A}$ , $T_J=25^{\circ}\text{C}$		10	120	mV
		$I_{OUT}=250\text{mA}\sim 750\text{mA}$ , $T_J=25^{\circ}\text{C}$		3	60	mV
Quiescent Current	$I_Q$	$T_J=25^{\circ}\text{C}$		3	6	mA
Quiescent Current Change	$\Delta I_Q$	$I_{OUT}=5\text{mA}\sim 1\text{A}$		0.05	0.5	mA
		$V_{IN}=-8\text{V}\sim -25\text{V}$		0.1	1.3	mA
Output Noise Voltage	eN	$f=10\text{Hz}\sim 100\text{kHz}$ , $T_A=25^{\circ}\text{C}$		130		$\mu\text{V}$
Output Voltage Drift	$\Delta V_{OUT}/\Delta T$	$I_{OUT}=5\text{mA}$		-0.5		$\text{mV}/^{\circ}\text{C}$
Peak Current	$I_{PEAK}$	$T_J=25^{\circ}\text{C}$		2.2		A

■ ELECTRICAL CHARACTERISTICS(Cont.)

For UTC 79D07AS ( $V_{IN}=-13V$ )

PARAMETER	SYMBOL	TEST CONDITIONS	MIN	TYP	MAX	UNIT
Output Voltage	$V_{OUT}$	$T_J=25^{\circ}C$	-6.72	-7.0	-7.28	V
		$V_{IN}=-10.5V\sim-23V, I_{OUT}=5mA\sim 1A$	-6.65		-7.35	V
Dropout Voltage	$V_D$	$I_{OUT}=1A$ $T_J=25^{\circ}C$		2		V
Line Regulation	$\Delta V_{OUT}$	$V_{IN}=-10.5V\sim-25V$ $T_J=25^{\circ}C$		10	140	mV
		$V_{IN}=-11.5V\sim-17V$ $T_J=25^{\circ}C$		5	70	mV
Load Regulation	$\Delta V_{OUT}$	$I_{OUT}=5mA\sim 1A$ $T_J=25^{\circ}C$		12		mV
		$I_{OUT}=250mA\sim 750mA$ $T_J=25^{\circ}C$		4		mV
Quiescent Current	$I_Q$	$T_J=25^{\circ}C$		3	6	mA
Quiescent Current Change	$\Delta I_Q$	$I_{OUT}=5mA\sim 1A$		0.05	0.5	mA
		$V_{IN}=-11.5V\sim-25V$		0.1	1.3	mA
Output Noise Voltage	eN	$f=10Hz\sim 100kHz$ $T_A=25^{\circ}C$		175		$\mu V$
Output Voltage Drift	$\Delta V_{OUT}/\Delta T$	$I_{OUT}=5mA$		-0.6		$mV/^{\circ}C$
Peak Current	$I_{PEAK}$	$T_J=25^{\circ}C$		2.2		A

For UTC 79D08AS ( $V_{IN}=-14V$ )

PARAMETER	SYMBOL	TEST CONDITIONS	MIN	TYP	MAX	UNIT
Output Voltage	$V_{OUT}$	$T_J=25^{\circ}C$	-7.68	-8.0	-8.32	V
		$V_{IN}=-10.5V\sim-23V, I_{OUT}=5mA\sim 1A$	-7.60		-8.40	V
Dropout Voltage	$V_D$	$I_{OUT}=1A$ $T_J=25^{\circ}C$		2		V
Line Regulation	$\Delta V_{OUT}$	$V_{IN}=-10.5V\sim-25V$ $T_J=25^{\circ}C$		10	160	mV
		$V_{IN}=-11.5V\sim-17V$ $T_J=25^{\circ}C$		5	80	mV
Load Regulation	$\Delta V_{OUT}$	$I_{OUT}=5mA\sim 1A$ $T_J=25^{\circ}C$		12	160	mV
		$I_{OUT}=250mA\sim 750mA$ $T_J=25^{\circ}C$		4	80	mV
Quiescent Current	$I_Q$	$T_J=25^{\circ}C$		3	6	mA
Quiescent Current Change	$\Delta I_Q$	$I_{OUT}=5mA\sim 1A$		0.05	0.5	mA
		$V_{IN}=-11.5V\sim-25V$		0.1	1.0	mA
Output Noise Voltage	eN	$f=10Hz\sim 100kHz$ $T_A=25^{\circ}C$		175		$\mu V$
Output Voltage Drift	$\Delta V_{OUT}/\Delta T$	$I_{OUT}=5mA$		-0.6		$mV/^{\circ}C$
Peak Current	$I_{PEAK}$	$T_J=25^{\circ}C$		2.2		A

For UTC 79D09AS ( $V_{IN}=-15V$ )

PARAMETER	SYMBOL	TEST CONDITIONS	MIN	TYP	MAX	UNIT
Output Voltage	$V_{OUT}$	$T_J=25^{\circ}C$	-8.64	-9.0	-9.36	V
		$V_{IN}=-11.5V\sim-23V, I_{OUT}=5mA\sim 1A$	-8.55		-9.45	V
Dropout Voltage	$V_D$	$I_{OUT}=1A$ $T_J=25^{\circ}C$		2		V
Line Regulation	$\Delta V_{OUT}$	$V_{IN}=-11.5V\sim-26V$ $T_J=25^{\circ}C$		10	180	mV
		$V_{IN}=-12V\sim-18V$ $T_J=25^{\circ}C$		5	90	mV
Load Regulation	$\Delta V_{OUT}$	$I_{OUT}=5mA\sim 1A$ $T_J=25^{\circ}C$		12	180	mV
		$I_{OUT}=250mA\sim 750mA$ $T_J=25^{\circ}C$		4	90	mV
Quiescent Current	$I_Q$	$T_J=25^{\circ}C$		3	6	mA
Quiescent Current Change	$\Delta I_Q$	$I_{OUT}=5mA\sim 1A$		0.05	0.5	mA
		$V_{IN}=-11.5V\sim-26V$		0.1	1.0	mA
Output Noise Voltage	eN	$f=10Hz\sim 100kHz$ $T_A=25^{\circ}C$		175		$\mu V$
Output Voltage Drift	$\Delta V_{OUT}/\Delta T$	$I_{OUT}=5mA$		-0.6		$mV/^{\circ}C$
Peak Current	$I_{PEAK}$	$T_J=25^{\circ}C$		2.2		A

■ ELECTRICAL CHARACTERISTICS(Cont.)

For UTC 79D12AS ( $V_{IN}=-18V$ )

PARAMETER	SYMBOL	TEST CONDITIONS	MIN	TYP	MAX	UNIT
Output Voltage	$V_{OUT}$	$T_J=25^{\circ}C$	-11.52	-12.0	-12.48	V
		$V_{IN}=-14.5V\sim-27V, I_{OUT}=5mA\sim 1A$	-11.40		-12.60	V
Dropout Voltage	$V_D$	$I_{OUT}=1A, T_J=25^{\circ}C$		2		V
Line Regulation	$\Delta V_{OUT}$	$V_{IN}=-14.5V\sim-30V, T_J=25^{\circ}C$		12	240	mV
		$V_{IN}=-16V\sim-22V, T_J=25^{\circ}C$		6	120	mV
Load Regulation	$\Delta V_{OUT}$	$I_{OUT}=5mA\sim 1A, T_J=25^{\circ}C$		12	240	mV
		$I_{OUT}=250mA\sim 750mA, T_J=25^{\circ}C$		4	120	mV
Quiescent Current	$I_Q$	$T_J=25^{\circ}C$		3	6	mA
Quiescent Current Change	$\Delta I_Q$	$I_{OUT}=5mA\sim 1A$		0.05	0.5	mA
		$V_{IN}=-14.5V\sim-30V$		0.1	1.0	mA
Output Noise Voltage	eN	$f=10Hz\sim 100kHz, T_A=25^{\circ}C$		200		$\mu V$
Output Voltage Drift	$\Delta V_{OUT}/\Delta T$	$I_{OUT}=5mA$		-0.8		$mV/^{\circ}C$
Peak Current	$I_{PEAK}$	$T_J=25^{\circ}C$		2.2		A

For UTC 79D15AS ( $V_{IN}=-23V$ )

PARAMETER	SYMBOL	TEST CONDITIONS	MIN	TYP	MAX	UNIT
Output Voltage	$V_{OUT}$	$T_J=25^{\circ}C$	-14.40	-15.0	-15.60	V
		$V_{IN}=-17.5V\sim-30V, I_{OUT}=5mA\sim 1A$	-14.25		-15.75	V
Dropout Voltage	$V_D$	$I_{OUT}=1A, T_J=25^{\circ}C$		2		V
Line Regulation	$\Delta V_{OUT}$	$V_{IN}=-17.5V\sim-30V, T_J=25^{\circ}C$		12	300	mV
		$V_{IN}=-20V\sim-26V, T_J=25^{\circ}C$		6	150	mV
Load Regulation	$\Delta V_{OUT}$	$I_{OUT}=5mA\sim 1A, T_J=25^{\circ}C$		12	300	mV
		$I_{OUT}=250mA\sim 750mA, T_J=25^{\circ}C$		4	150	mV
Quiescent Current	$I_Q$	$T_J=25^{\circ}C$		3	6	mA
Quiescent Current Change	$\Delta I_Q$	$I_{OUT}=5mA\sim 1A$		0.05	0.5	mA
		$V_{IN}=-17.5V\sim-30.5V$		0.1	1.0	mA
Output Noise Voltage	eN	$f=10Hz\sim 100kHz, T_A=25^{\circ}C$		250		$\mu V$
Output Voltage Drift	$\Delta V_{OUT}/\Delta T$	$I_{OUT}=5mA$		-0.9		$mV/^{\circ}C$
Peak Current	$I_{PEAK}$	$T_J=25^{\circ}C$		2.2		A

■ ELECTRICAL CHARACTERISTICS(Cont.)

For UTC 79D18AS ( $V_{IN}=-27V$ )

PARAMETER	SYMBOL	TEST CONDITIONS	MIN	TYP	MAX	UNIT
Output Voltage	$V_{OUT}$	$T_J=25^{\circ}C$	-17.28	-18.0	-18.72	V
		$V_{IN}=-21V\sim-33V, I_{OUT}=5mA\sim 1A$	-17.10		-18.90	V
Dropout Voltage	$V_D$	$I_{OUT}=1A$ $T_J=25^{\circ}C$		2		V
Line Regulation	$\Delta V_{OUT}$	$V_{IN}=-21V\sim-33V$ $T_J=25^{\circ}C$		15	360	mV
		$V_{IN}=-24V\sim-30V$ $T_J=25^{\circ}C$		8	180	mV
Load Regulation	$\Delta V_{OUT}$	$I_{OUT}=5mA\sim 1A$ $T_J=25^{\circ}C$		15	360	mV
		$I_{OUT}=250mA\sim 750mA$ $T_J=25^{\circ}C$		5.0	180	mV
Quiescent Current	$I_Q$	$T_J=25^{\circ}C$		3	6	mA
Quiescent Current Change	$\Delta I_Q$	$I_{OUT}=5mA\sim 1A$		0.05	0.5	mA
		$V_{IN}=-21V\sim-32V$		0.1	1.0	mA
Output Noise Voltage	eN	$f=10Hz\sim 100kHz$ $T_A=25^{\circ}C$		300		$\mu V$
Output Voltage Drift	$\Delta V_{OUT}/\Delta T$	$I_{OUT}=5mA$		-1		$mV/^{\circ}C$
Peak Current	$I_{PEAK}$	$T_J=25^{\circ}C$		2.2		A

For UTC 79D24AS ( $V_{IN}=-33V$ )

PARAMETER	SYMBOL	TEST CONDITIONS	MIN	TYP	MAX	UNIT
Output Voltage	$V_{OUT}$	$T_J=25^{\circ}C$	-23.04	-24	-24.96	V
		$V_{IN}=-27V\sim-38V, I_{OUT}=5mA\sim 1A$	-22.80		-25.20	V
Dropout Voltage	$V_D$	$I_{OUT}=1.0A$ $T_J=25^{\circ}C$		2		V
Line Regulation	$\Delta V_{OUT}$	$V_{IN}=-27V\sim-38V$ $T_J=25^{\circ}C$		15	480	mV
		$V_{IN}=-30V\sim-36V$ $T_J=25^{\circ}C$		8	240	mV
Load Regulation	$\Delta V_{OUT}$	$I_{OUT}=5mA\sim 1A$ $T_J=25^{\circ}C$		15	480	mV
		$I_{OUT}=250mA\sim 750mA$ $T_J=25^{\circ}C$		5.0	240	mV
Quiescent Current	$I_Q$	$T_J=25^{\circ}C$		3	6	mA
Quiescent Current Change	$\Delta I_Q$	$I_{OUT}=5mA\sim 1A$		0.05	0.5	mA
		$V_{IN}=-27V\sim-38V$		0.1	1.0	mA
Output Noise Voltage	eN	$f=10Hz\sim 100kHz$ $T_A=25^{\circ}C$		400		$\mu V$
Output Voltage Drift	$\Delta V_{OUT}/\Delta T$	$I_{OUT}=5mA$		-1		$mV/^{\circ}C$
Peak Current	$I_{PEAK}$	$T_J=25^{\circ}C$		2.2		A

Note: 1. Thermal resistance test board.

■ APPLICATION CIRCUITS

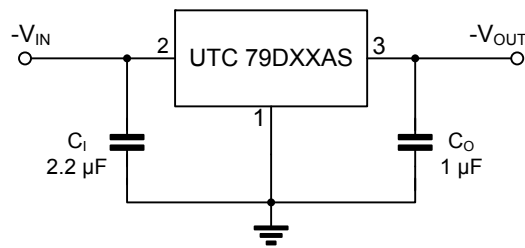

Fig.1 Fixed output regulator

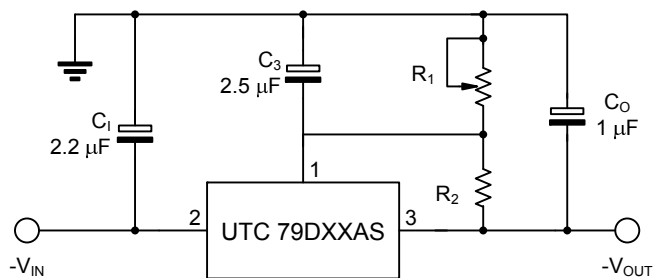

Fig.2 Circuit for increasing output voltage

UTC assumes no responsibility for equipment failures that result from using products at values that exceed, even momentarily, rated values (such as maximum ratings, operating condition ranges, or other parameters) listed in products specifications of any and all UTC products described or contained herein. UTC products are not designed for use in life support appliances, devices or systems where malfunction of these products can be reasonably expected to result in personal injury. Reproduction in whole or in part is prohibited without the prior written consent of the copyright owner. UTC reserves the right to make changes to information published in this document, including without limitation specifications and product descriptions, at any time and without notice. This document supersedes and replaces all information supplied prior to the publication hereof.