



## U74HC595P

Preliminary

CMOS IC

### 8-BIT SERIAL-IN SHIFT REGISTER WITH LATCHED 3-STATE PARALLEL OUTPUTS, PROVIDING SERIAL OUTPUT

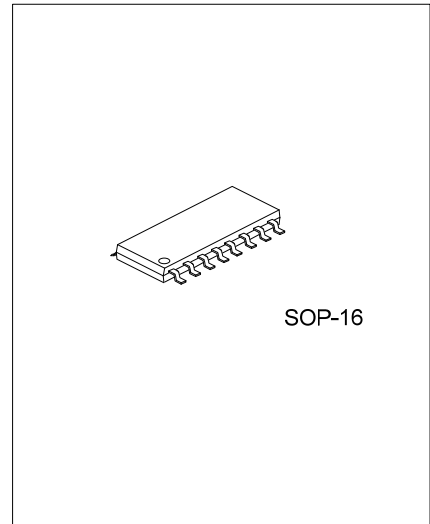

#### DESCRIPTION

The UTC **U74HC595P** contains an 8-bit register with asynchronous reset input and an 8-bit latch with output. The Serial Data Input (SER) will shift into the internal shift register during every LOW-to-HIGH transition on the Shift Clock. The latch will latch the 8-bit data from the shift register during the LOW-to-HIGH transition on the Latch Clock. The shift register also provides a serial output.

#### FEATURES

- \* Operation Voltage Range: 2~6V
- \* High Noise Immunity
- \* Output Compatibility with CMOS and TTL
- \* Specified from -40 ~ +125°C

#### ORDERING INFORMATION

Ordering Number		Package	Packing
Lead Free	Halogen Free		
U74HC595PL-S16-R	U74HC595PG-S16-R	SOP-16	Tape Reel

<p>U74HC595PG-S16-R</p>	<p>(1) R: Tape Reel (2) S16: SOP-16 (3) G: Halogen Free and Lead Free, L: Lead Free</p>
-------------------------	---

#### MARKING

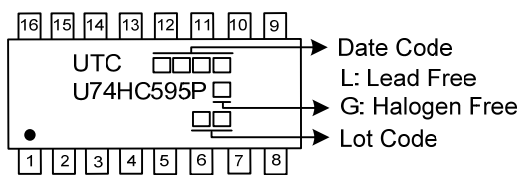

■ PIN CONFIGURATION

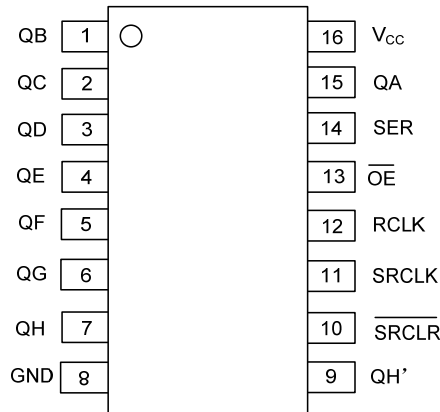

■ FUNCTION TABLE

FUNCTION	INPUTS					OUTPUTS	
	SRCLK	RCLK	$\overline{OE}$	$\overline{SRCLR}$	SER	QH'	Qn
A Low-Level on $\overline{SRCLR}$ only affects the shift registers.	X	X	L	L	X	L	NC
Empty shift register loaded into storage register.	X	↑	L	L	X	L	L
Shift register clear. Parallel outputs in high-impedance OFF-state	X	X	H	L	X	L	Z
Logic high level shifted into the first shift register. Contents of all shift register stages shifted through, e.g. previous state of stage G(internal QG') appears on the serial output(QH').	↑	X	L	H	H	QG'	NC
Contents of shift register stages (internal Qn') are transferred to the storage register and parallel output stages.	X	↑	L	H	X	NC	Qn'
Contents of shift register shifted through. Previous contents of the shift register is transferred to the storage register and the parallel output stages.	↑	↑	L	H	X	QG'	Qn'

Note: H : HIGH voltage level.  
 L : LOW voltage level.  
 X : Don't care.  
 Z : High impedance OFF-state.  
 NC: No change.  
 ↑ : Low-to-High transition.  
 ↓ : High-to-Low transition.

■ LOGIC DIAGRAM

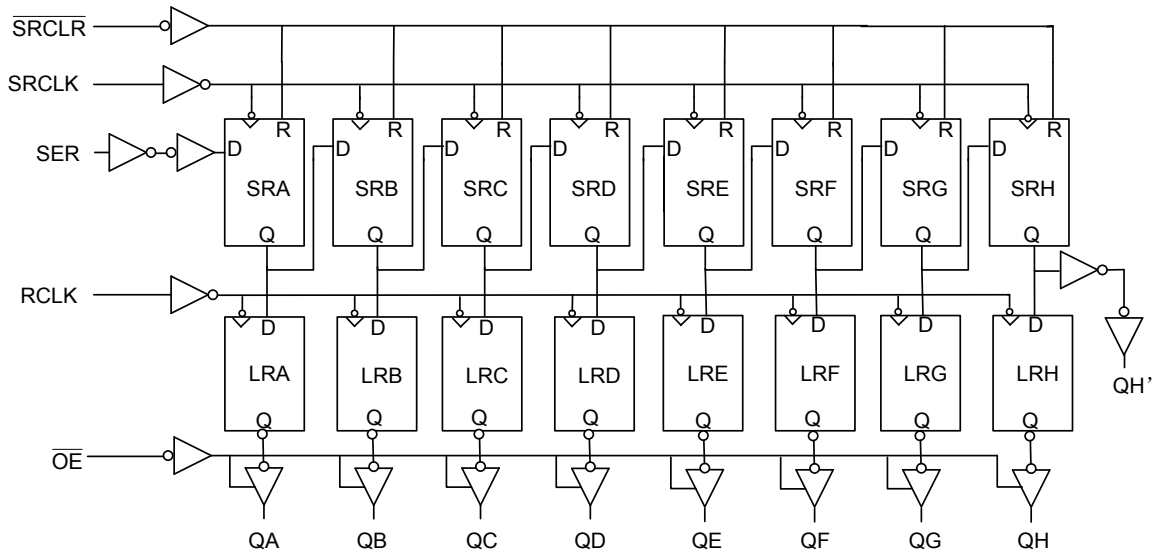

■ TIMING DIAGRAM

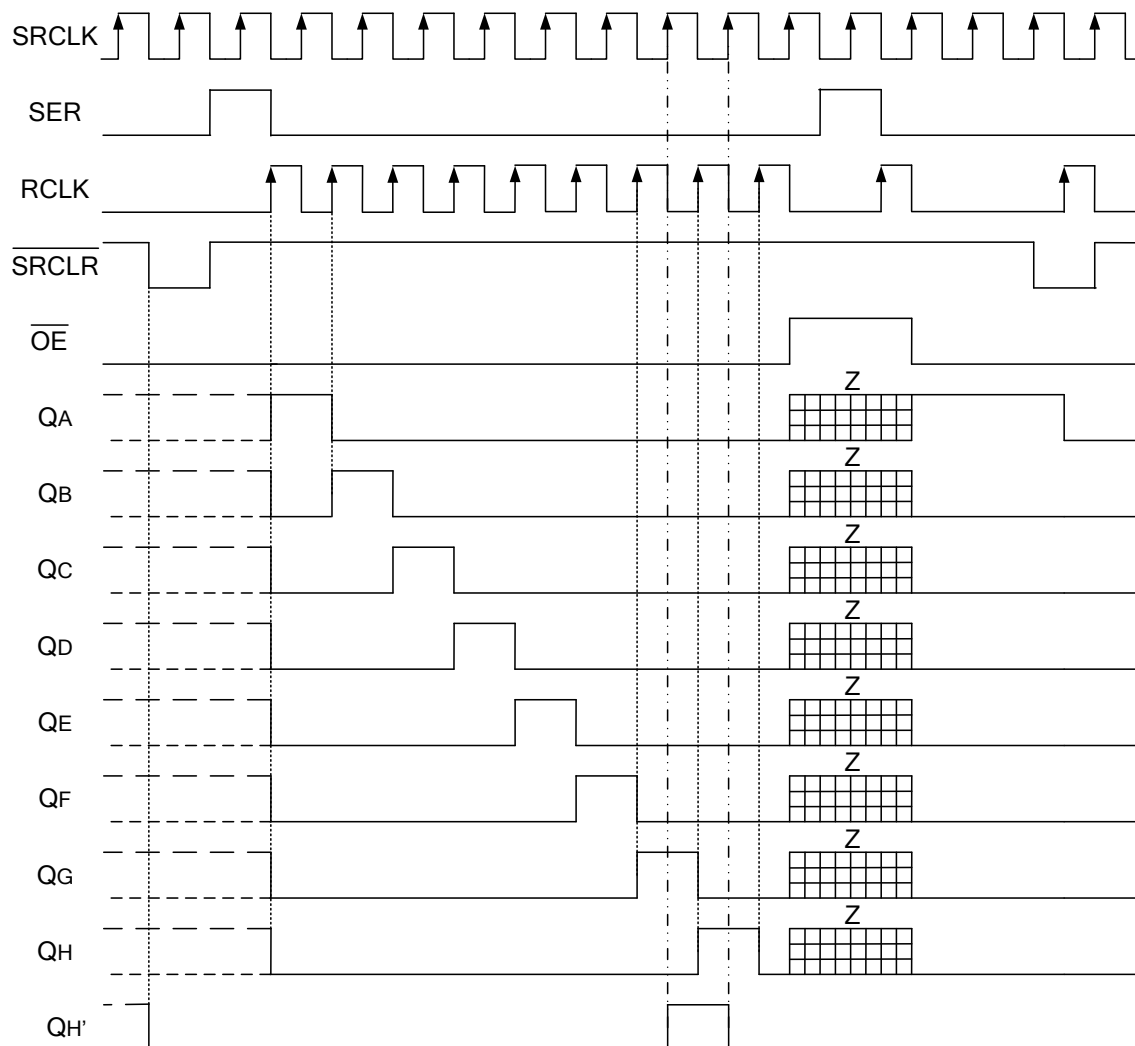

■ ABSOLUTE MAXIMUM RATING (unless otherwise specified)(Note 2)

PARAMETER	SYMBOL	RATINGS	UNIT
Supply Voltage	$V_{CC}$	-0.5 ~ 7.0	V
Input Clamp Current ( $V_{IN} < 0$ )	$I_{IK}$	$\pm 20$	mA
Output Clamp Current ( $V_{OUT} < 0$ )	$I_{OK}$	$\pm 20$	mA
Output Current	$I_{OUT}$	$\pm 35$	mA
$V_{CC}$ or GND Current	$I_{CC}$	$\pm 75$	mA
Power Dissipation	$P_D$	500	mW
Storage Temperature	$T_{STG}$	-65 ~ +150	$^{\circ}C$

Notes: 1. Absolute maximum ratings are those values beyond which the device could be permanently damaged.

Absolute maximum ratings are stress ratings only and functional device operation is not implied.

2. The input and output voltage ratings may be exceeded if the input and output current ratings are observed.

■ RECOMMENDED OPERATING CONDITIONS

PARAMETER	SYMBOL	MIN	TYP	MAX	UNIT
Supply Voltage	$V_{CC}$	2		6	V
Input Voltage	$V_{IN}$	0		$V_{CC}$	V
Output Voltage	$V_{OUT}$	0		$V_{CC}$	V
Operating Temperature	$T_A$	-40		+125	$^{\circ}C$
Input Transition Rise or Fall Time	$V_{CC}=2V$	$t_R / t_F$		100	ns
	$V_{CC}=4.5V$			20	ns
	$V_{CC}=6V$			20	ns

■ ELECTRICAL CHARACTERISTICS (unless otherwise specified)

PARAMETER	SYMBOL	TEST CONDITIONS	T <sub>A</sub> =25°C			T <sub>A</sub> =-40°C~+125°C			UNIT
			MIN	TYP	MAX	MIN	TYP	MAX	
HIGH-level input voltage	V <sub>IH</sub>	V <sub>CC</sub> =2V	1.5			1.5			V
		V <sub>CC</sub> =3V	2.1			2.1			V
		V <sub>CC</sub> =4.5V	3.15			3.15			V
		V <sub>CC</sub> =6V	4.2			4.2			V
LOW-level output voltage	V <sub>IL</sub>	V <sub>CC</sub> =2V			0.5			0.5	V
		V <sub>CC</sub> =3V			0.9			0.9	V
		V <sub>CC</sub> =4.5V			1.35			1.35	V
		V <sub>CC</sub> =6V			1.8			1.8	V
High-Level Output Voltage, Q <sub>A</sub> -Q <sub>H</sub>	V <sub>OH</sub>	V <sub>CC</sub> =2V, I <sub>OH</sub> =-20μA	1.9	2.0		1.9			V
		V <sub>CC</sub> =4.5V, I <sub>OH</sub> =-20μA	4.4	4.5		4.4			V
		V <sub>CC</sub> =6V, I <sub>OH</sub> =-20μA	5.9	6.0		5.9			V
		V <sub>CC</sub> =3V, I <sub>OH</sub> =-2.4mA	2.48			2.3			V
		V <sub>CC</sub> =4.5V, I <sub>OH</sub> =-6mA	3.98			3.7			V
		V <sub>CC</sub> =6V, I <sub>OH</sub> =-7.8mA	5.48			5.2			V
Low-Level Output Voltage, Q <sub>A</sub> -Q <sub>H</sub>	V <sub>OL</sub>	V <sub>CC</sub> =2V, I <sub>OL</sub> =20μA		0.002	0.1			0.1	V
		V <sub>CC</sub> =4.5V, I <sub>OL</sub> =20μA		0.001	0.1			0.1	V
		V <sub>CC</sub> =6V, I <sub>OL</sub> =20μA		0.001	0.1			0.1	V
		V <sub>CC</sub> =3V, I <sub>OL</sub> =2.4mA			0.26			0.4	V
		V <sub>CC</sub> =4.5V, I <sub>OL</sub> =6mA			0.26			0.4	V
		V <sub>CC</sub> =6V, I <sub>OL</sub> =7.8mA			0.26			0.4	V
High-Level Output Voltage, Q <sub>H</sub> '	V <sub>OH</sub>	V <sub>CC</sub> =2V, I <sub>OH</sub> =-20μA	1.9	2.0		1.9			V
		V <sub>CC</sub> =4.5V, I <sub>OH</sub> =-20μA	4.4	4.5		4.4			V
		V <sub>CC</sub> =6V, I <sub>OH</sub> =-20μA	5.9	6.0		5.9			V
		V <sub>CC</sub> =3V, I <sub>OH</sub> =-2.4mA	2.48			2.3			V
		V <sub>CC</sub> =4.5V, I <sub>OH</sub> =-4mA	3.98			3.7			V
		V <sub>CC</sub> =6V, I <sub>OH</sub> =-5.2mA	5.48			5.2			V
Low-Level Output Voltage, Q <sub>H</sub> '	V <sub>OL</sub>	V <sub>CC</sub> =2V, I <sub>OL</sub> =20μA		0.002	0.1			0.1	V
		V <sub>CC</sub> =4.5V, I <sub>OL</sub> =20μA		0.001	0.1			0.1	V
		V <sub>CC</sub> =6V, I <sub>OL</sub> =20μA		0.001	0.1			0.1	V
		V <sub>CC</sub> =3V, I <sub>OL</sub> =2.4mA			0.26			0.4	V
		V <sub>CC</sub> =4.5V, I <sub>OL</sub> =4mA			0.26			0.4	V
		V <sub>CC</sub> =6V, I <sub>OL</sub> =5.2mA			0.26			0.4	V
Input Leakage Current	I <sub>I(LEAK)</sub>	V <sub>CC</sub> =6V, V <sub>IN</sub> =V <sub>CC</sub> or GND			±0.1			±1	μA
Output OFF -state current	I <sub>OZ</sub>	V <sub>CC</sub> =6V, V <sub>OUT</sub> =V <sub>CC</sub> or GND			±0.5			±10	μA
Quiescent Supply Current	I <sub>CC</sub>	V <sub>CC</sub> =6V, V <sub>IN</sub> =V <sub>CC</sub> or GND, I <sub>OUT</sub> =0			4			160	μA

■ DYNAMIC CHARACTERISTICS (unless otherwise specified)

PARAMETER	SYMBOL	TEST CONDITIONS	T <sub>A</sub> =25°C			T <sub>A</sub> =-40°C~+125°C			UNIT	
			MIN	TYP	MAX	MIN	TYP	MAX		
Maximum clock pulse frequency	f <sub>max</sub>	C <sub>L</sub> =50pF	V <sub>CC</sub> =2V	6	26		4		MHz	
			V <sub>CC</sub> =4.5V	30	38		20		MHz	
			V <sub>CC</sub> =6V	35	42		24		MHz	
Propagation delay from input (SRCLK) to output (Q <sub>H</sub> )	t <sub>PD</sub>	C <sub>L</sub> =50pF	V <sub>CC</sub> =2V		50	140			265	ns
			V <sub>CC</sub> =4.5V		17	28			53	ns
			V <sub>CC</sub> =6V		14	24			45	ns
Propagation delay from input (RCLK) to output (Q <sub>A</sub> -Q <sub>H</sub> )	t <sub>PD</sub>	C <sub>L</sub> =50pF	V <sub>CC</sub> =2V		50	140			265	ns
			V <sub>CC</sub> =4.5V		17	28			53	ns
			V <sub>CC</sub> =6V		14	24			45	ns
		C <sub>L</sub> =150pF	V <sub>CC</sub> =2V		60	200			250	ns
			V <sub>CC</sub> =4.5V		22	40			50	ns
			V <sub>CC</sub> =6V		19	34			43	ns
Propagation delay from input (SRCLR) to output (Q <sub>H</sub> )	t <sub>PHL</sub>	C <sub>L</sub> =50pF	V <sub>CC</sub> =2V		51	145			265	ns
			V <sub>CC</sub> =4.5V		18	29			53	ns
			V <sub>CC</sub> =6V		15	25			45	ns
Propagation delay from input (OE) to output (Q <sub>A</sub> -Q <sub>H</sub> )	t <sub>en</sub>	C <sub>L</sub> =50pF	V <sub>CC</sub> =2V		40	135			225	ns
			V <sub>CC</sub> =4.5V		15	27			45	ns
			V <sub>CC</sub> =6V		13	23			38	ns
		C <sub>L</sub> =150pF	V <sub>CC</sub> =2V		70	200			250	ns
			V <sub>CC</sub> =4.5V		23	40			50	ns
			V <sub>CC</sub> =6V		19	34			43	ns
Propagation delay from input (OE) to output (Q <sub>A</sub> -Q <sub>H</sub> )	t <sub>dis</sub>	C <sub>L</sub> =50pF	V <sub>CC</sub> =2V		42	150			250	ns
			V <sub>CC</sub> =4.5V		23	30			50	ns
			V <sub>CC</sub> =6V		20	26			43	ns
Propagation delay to output (Q <sub>A</sub> -Q <sub>H</sub> )	t <sub>t</sub>	C <sub>L</sub> =50pF	V <sub>CC</sub> =2V		28	60			75	ns
			V <sub>CC</sub> =4.5V		8	12			15	ns
			V <sub>CC</sub> =6V		6	10			13	ns
		C <sub>L</sub> =150pF	V <sub>CC</sub> =2V		45	210			265	ns
			V <sub>CC</sub> =4.5V		17	42			53	ns
			V <sub>CC</sub> =6V		13	36			45	ns
Propagation delay to output (Q <sub>H</sub> )	t <sub>t</sub>	C <sub>L</sub> =50pF	V <sub>CC</sub> =2V		28	75			95	ns
			V <sub>CC</sub> =4.5V		8	15			19	ns
			V <sub>CC</sub> =6V		6	13			16	ns

■ TIMING REQUIREMENTS (unless otherwise specified)

PARAMETER	SYMBOL	TEST CONDITIONS	T <sub>A</sub> =25°C			T <sub>A</sub> =-40°C~+125°C			UNIT
			MIN	TYP	MAX	MIN	TYP	MAX	
Pulse duration, SRCLK or RCLK high or low	t <sub>w</sub>	V <sub>CC</sub> =2V	80			110			ns
		V <sub>CC</sub> =4.5V	16			22			ns
		V <sub>CC</sub> =6V	14			19			ns
Pulse duration, SRCLR Low		V <sub>CC</sub> =2V	80			110			ns
		V <sub>CC</sub> =4.5V	16			22			ns
		V <sub>CC</sub> =6V	14			19			ns
Setup Time, SER before SRCLK↑	t <sub>su</sub>	V <sub>CC</sub> =2V	100			125			ns
		V <sub>CC</sub> =4.5V	20			25			ns
		V <sub>CC</sub> =6V	17			21			ns
Setup Time, SRCLK↑ before RCLK↑		V <sub>CC</sub> =2V	75			94			ns
		V <sub>CC</sub> =4.5V	15			19			ns
		V <sub>CC</sub> =6V	13			16			ns
Setup Time, SRCLR low before RCLK↑		V <sub>CC</sub> =2V	50			65			ns
		V <sub>CC</sub> =4.5V	10			13			ns
		V <sub>CC</sub> =6V	9			11			ns
Setup Time, SRCLR high (inactive) before SRCLK↑		V <sub>CC</sub> =2V	50			60			ns
		V <sub>CC</sub> =4.5V	10			12			ns
		V <sub>CC</sub> =6V	9			11			ns
Hold Time, SER after SRCLK↑	t <sub>h</sub>	V <sub>CC</sub> =2V	3			3			ns
		V <sub>CC</sub> =4.5V	3			3			ns
		V <sub>CC</sub> =6V	3			3			ns

■ OPERATING CHARACTERISTIC

PARAMETER	SYMBOL	TEST CONDITIONS	MIN	TYP	MAX	UNIT
Input Capacitance	C <sub>IN</sub>	V <sub>CC</sub> =6V, V <sub>IN</sub> =V <sub>CC</sub> or GND			10	pF
Power Dissipation Capacitance	C <sub>PD</sub>	No load		400		pF

■ TEST CIRCUIT AND WAVEFORMS

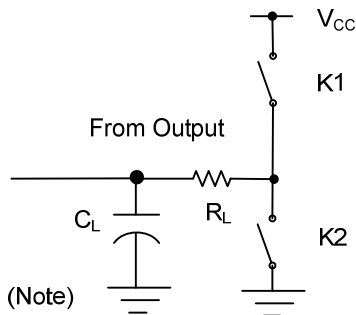

TEST	K1	K2
$t_{PLH}/t_{PHL}$	Open	Open
$t_{PHZ}/t_{PZH}$	Open	Close
$t_{PLZ}/t_{PZL}$	Close	Open

$t_{PD}$  is the same as  $t_{PHL}$  and  $t_{PLH}$ .  
 $t_{en}$  is the same as  $t_{PZL}$  and  $t_{PZH}$ .  
 $t_{dis}$  is the same as  $t_{PLZ}$  and  $t_{PHZ}$ .

Note:  $C_L$  includes probe and jig capacitance.  $C_L=50pF$ ,  $R_L=1K\Omega$

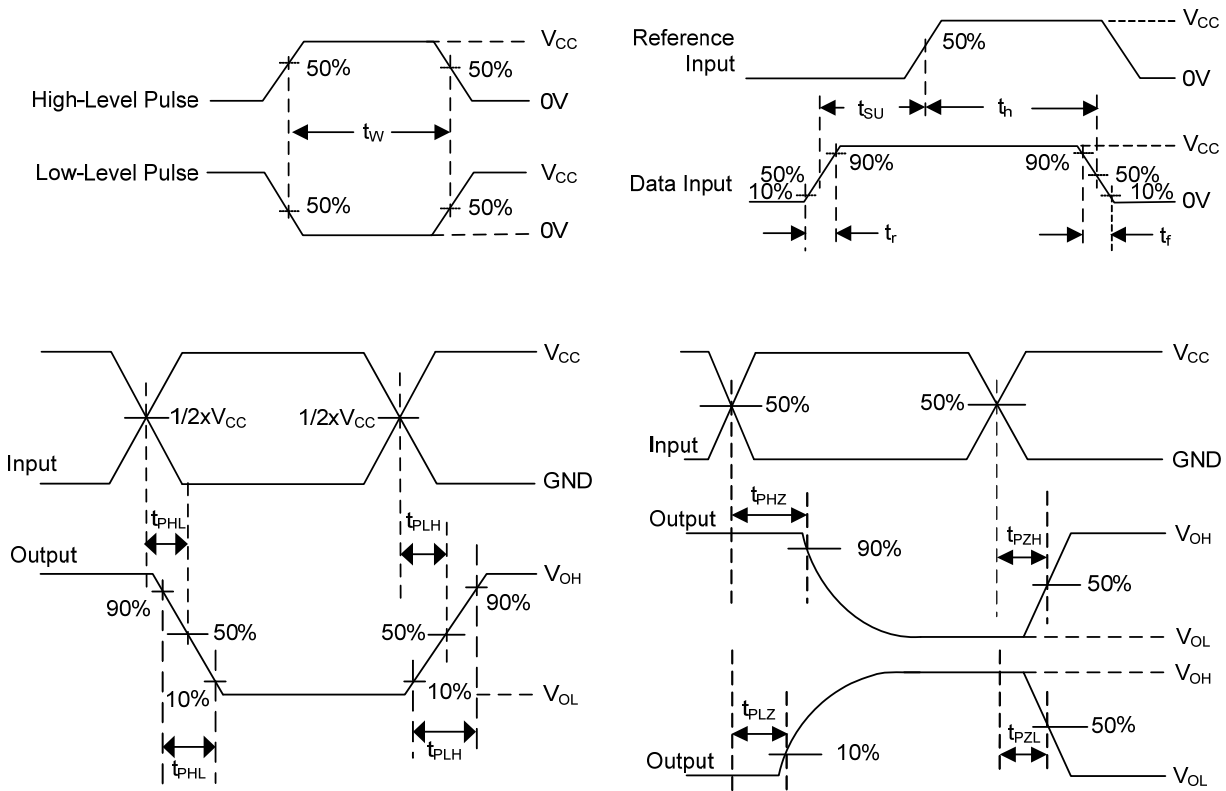

UTC assumes no responsibility for equipment failures that result from using products at values that exceed, even momentarily, rated values (such as maximum ratings, operating condition ranges, or other parameters) listed in products specifications of any and all UTC products described or contained herein. UTC products are not designed for use in life support appliances, devices or systems where malfunction of these products can be reasonably expected to result in personal injury. Reproduction in whole or in part is prohibited without the prior written consent of the copyright owner. UTC reserves the right to make changes to information published in this document, including without limitation specifications and product descriptions, at any time and without notice. This document supersedes and replaces all information supplied prior to the publication hereof.