

禁用RoHS / REACH/SS00259 之有害物質

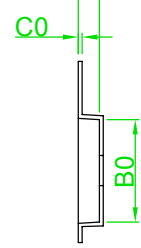

B-B'

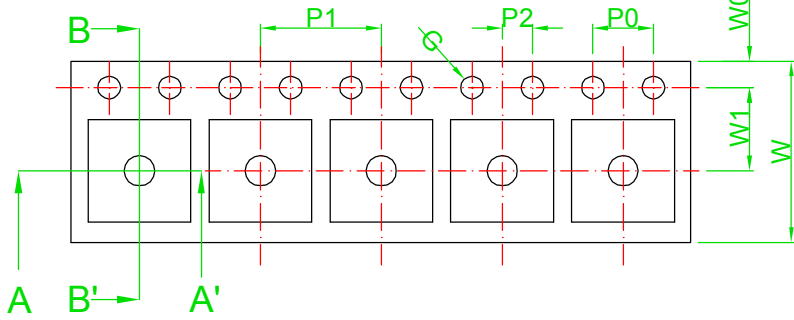

A-A'

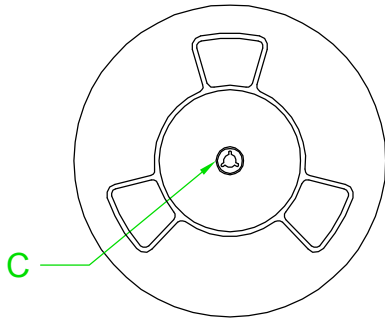

SCALE 1: 8

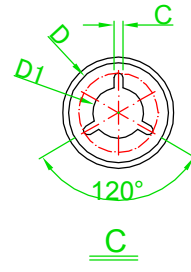
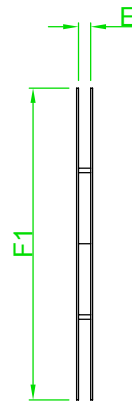

SCALE 1: 2

TSSOP-20 T/R

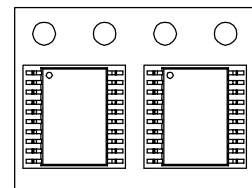

Symbol	Dimensions in Millimeters		Dimensions in Inches	
	Min	Max	Min	Max
A0	6.70	7.00	0.264	0.276
B0	6.70	7.00	0.264	0.276
C0	0.20	0.30	0.008	0.012
K0	1.60	1.80	0.063	0.071
W0	1.65	1.85	0.065	0.073
W1	5.40	5.60	0.213	0.220
W	11.70	12.30	0.461	0.484
P0	3.90	4.10	0.154	0.161
P1	7.90	8.10	0.311	0.319
P2	1.90	2.10	0.075	0.083
G	1.50	1.60	0.059	0.063
C	1.50	---	0.059	---
D	20.20	---	0.795	---
D1	---	29.20	---	1.150
E	12.50	13.50	0.492	0.531
F1	328.00	332.00	12.913	13.071



友順科技股份有限公司
UNISONIC TECHNOLOGIES CO.,LTD

正式發行圖面

SCALE	mm
2: 發行	0 30
SHEET	THIRD ANGLE PROJECTION
1 of 1	Dec 29 2020
ENG.	Kevin Huang 2020/12/23
APPR.	UTC Doc Control Center Kelvin Lee 2020/12/23

REV: A1
PART NO: TSSOP-20
DWG NO: TAPING-TSSOP-20-001-A1

TITLE
TSSOP-20
TAPING