

禁用RoHS / REACH/SS00259 之有害物質

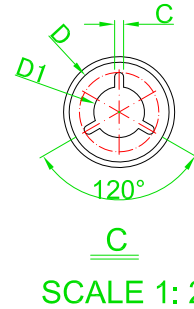

Symbol	Dimensions in Millimeters		Dimensions in Inches	
	Min	Max	Min	Max
A	1.65	1.85	0.065	0.073
A1	5.40	5.60	0.213	0.220
A2	11.70	12.30	0.461	0.484
B	1.95	2.05	0.077	0.081
B1	3.90	4.10	0.154	0.161
B2	7.90	8.10	0.311	0.319
C	2.15	3.65	0.085	0.144
D	20.70	21.30	0.815	0.839
D1	12.80	13.80	0.504	0.543
E	12.40	13.40	0.488	0.528
F	149.00	151.00	5.866	5.945
F1	325.00	335.00	12.795	13.189
G	1.50	1.60	0.059	0.063
A0	6.65	7.05	0.262	0.278
B0	5.30	5.70	0.209	0.224
K0	1.40	1.70	0.055	0.067

TSSOP-14/16 T/R

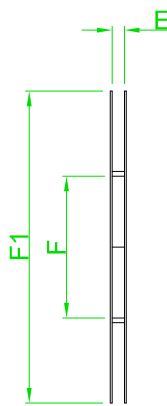
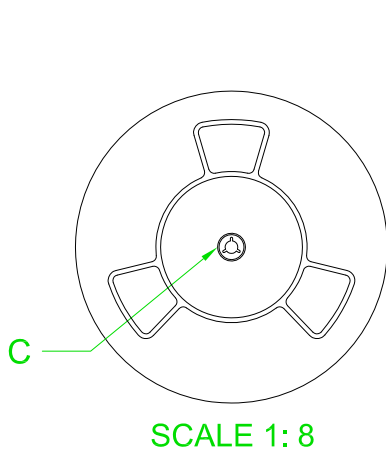
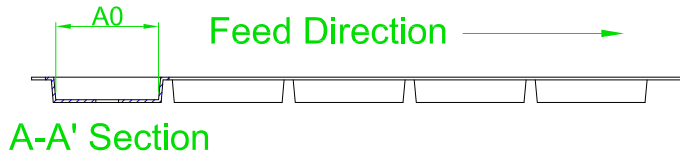
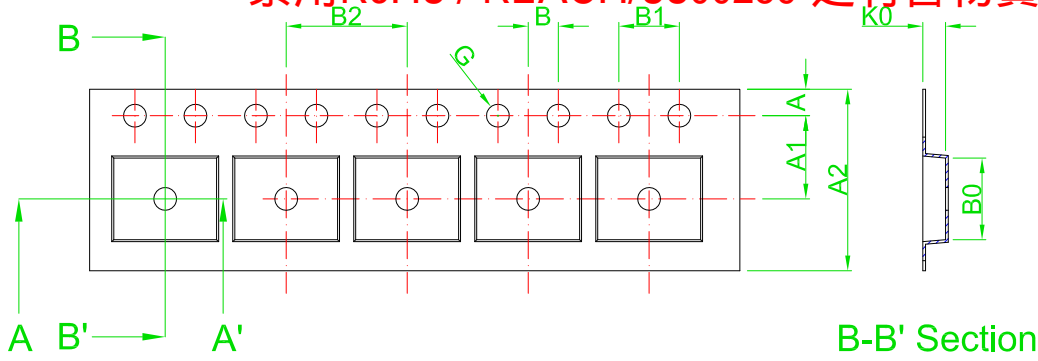
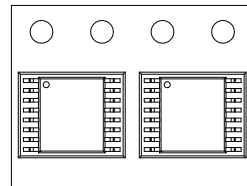

友順科技股份有限公司
UNISONIC TECHNOLOGIES CO.,LTD

正式發行圖面

SCALE	mm
2:發行	0 30
SHEET	THIRD ANGLE PROJECTION
1 of 1	DEC 03 2012
ENG. Naomi Lin	2012/11/28
APPR. Henry Hsiao	2012/11/28

REV: A0
PART NO: TSSOP-14/16
DWG NO: TAPING-TSSOP-14,16-001-A0

TITLE
TSSOP-14/16
TAPING