



## UESD5V0L1B

Preliminary

TVS

### ESD PROTECTION DEVICE

#### DESCRIPTION

The UTC **UESD5V0L1B** is bidirectional ElectroStatic Discharge (ESD). protection diode in leadless ultra small Surface-Mounted Device (SMD) plastic package designed to protect one signal line from the damage caused by ESD and other transients.

#### FEATURES

- \* Bidirectional protection of one line
- \* Reverse stand-off voltage:  $V_{RWM}=5V$
- \* Surge robustness:  $I_{PPM}=7.5A$  for  $8/20\mu s$  pulse
- \* Ultra low clamping voltage:  $V_{CL}=12.8V$  max. at  $I_{PPM}=7.5A$

#### SYMBOL

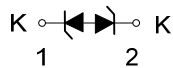

#### ORDERING INFORMATION

Ordering Number		Package	Pin Assignment		Packing
Lead Free	Halogen Free		1	2	
UESD5V0L1BL-CB2-R	UESD5V0L1BG-CB2-R	SOD-323	K	K	Tape Reel
UESD5V0L1BL-K02-1006X1-R	UESD5V0L1BG-K02-1006X1-R	X1DFN1006-2	K	K	Tape Reel

Note: Pin Assignment: K: Cathode

<p>UESD5V0L1BG-CB2-R</p> <p>(1) Packing Type (2) Package Type (3) Green Package</p>	<p>(1) R: Tape Reel (2) CB2: SOT-323, K02-1006X1: X1DFN1006-2 (3) G: Halogen Free and Lead Free, L: Lead Free</p>
---	---

#### MARKING

SOD-323	X1DFN1006-2

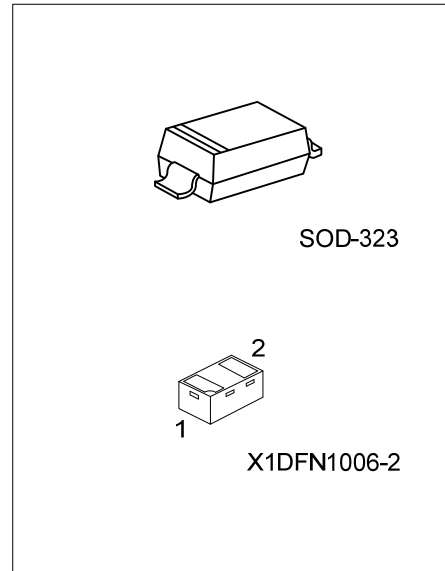

■ ABSOLUTE MAXIMUM RATINGS ( $T_A=25^\circ\text{C}$ , unless otherwise specified)

PARAMETER		SYMBOL	RATINGS	UNIT	
ESD Discharge	IEC61000-4-2	Air Discharge	$\pm 25$	kV	
		Contact Discharge	$\pm 25$	kV	
Peak Pulse Current	IEC61000-4-5	$t_p=8/20\mu\text{s}$	$I_{PP}$	7.5	A
Peak Pulse Power			$P_{PK}$	350	W
Operating Junction Temperature		$T_J$	-55 ~ +150	$^\circ\text{C}$	
Operating Temperature		$T_{OPR}$	-55 ~ +125	$^\circ\text{C}$	
Storage Temperature		$T_{STG}$	-55 ~ +150	$^\circ\text{C}$	

Note: Absolute maximum ratings are those values beyond which the device could be permanently damaged.  
Absolute maximum ratings are stress ratings only and functional device operation is not implied.

■ ELECTRICAL CHARACTERISTICS ( $T_A=25^\circ\text{C}$ , unless otherwise specified)

PARAMETER	SYMBOL	TEST CONDITIONS	MIN	TYP	MAX	UNIT
Reverse Stand-Off Voltage	$V_{RWM}$				5.0	V
Reverse Breakdown Voltage	$V_{BR}$	$I_R=1\text{mA}$	5.6	6.5	7.6	V
Reverse Current	$I_R$	$V_R=5.0\text{V}$			1.0	$\mu\text{A}$
Diode capacitance	$C_D$	$V_R=0\text{V}$ , $f=1\text{MHz}$		15.5	20	pF
Clamping Voltage (positive transient)	$V_{CL}$	$I_{PP}=1.0\text{A}$ , $t_p=8/20\mu\text{s}$ (Note)			8.3	V
		$I_{PPM}=7.5\text{A}$ , $t_p=8/20\mu\text{s}$ (Note)			12.8	V

Note: Device stressed with 8/20  $\mu\text{s}$  exponential decay waveform according to IEC 61000-4-5.

UTC assumes no responsibility for equipment failures that result from using products at values that exceed, even momentarily, rated values (such as maximum ratings, operating condition ranges, or other parameters) listed in products specifications of any and all UTC products described or contained herein. UTC products are not designed for use in life support appliances, devices or systems where malfunction of these products can be reasonably expected to result in personal injury. Reproduction in whole or in part is prohibited without the prior written consent of the copyright owner. UTC reserves the right to make changes to information published in this document, including without limitation specifications and product descriptions, at any time and without notice. This document supersedes and replaces all information supplied prior to the publication hereof.