



**UL318C**

Advance

**LINEAR INTEGRATED CIRCUIT**

**SERIAL-INTERFACED  
10-DIGIT LED CONTROLLER  
IC WITH KEYSKAN**

■ **DESCRIPTION**

The **UL318C** is a compact LED controller and driver that interface microprocessors to LED displays through a serial 3-wire interface. It drives LED connected in common anode configuration. The **UL318C** drives up to LEDs in 10 segment/7 digit~13 segment/4 digit configuration while functioning from a supply voltage of 5.0V.

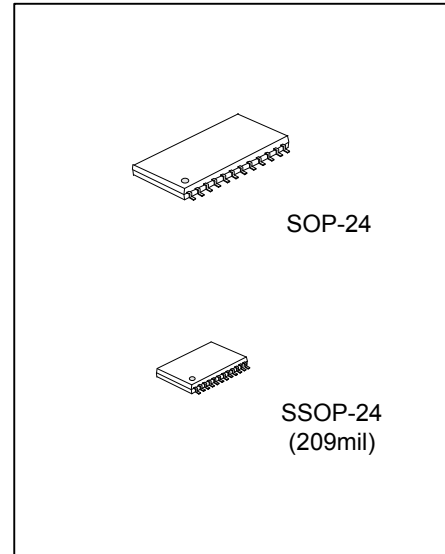

■ **FEATURES**

- \* LED driver with 17 outputs (10 segments/7 digits~13 segments/4 digits)
- \* Output pins connected directly to the LEDs
- \* Key-scanning (10 x 2 matrix)
- \* 3-wire serial bus interface (CLK, STB, DIO)
- \* 8-step dimming circuit to control the overall display brightness
- \* Inputs with Schmitt trigger give superior noise immunity
- \* 5.0 V (± 10%) for V<sub>DD</sub>
- \* Drives common-anode LED digits
- \* Built-in power on reset circuits
- \* Built-in pull-up resistor (CLK,STB,DIO)

■ **ORDERING INFORMATION**

Ordering Number		Package	Packing
Lead Free	Halogen Free		
UL318CL-R24-R	UL318CG-R24-R	SSOP-24	Tape Reel
UL318CL-S24-R	UL318CG-S24-R	SOP-24	Tape Reel

<p><b>UL318CG-R24-R</b></p> <p>(1) Packing Type (2) Package Type (3) Green Package</p>	<p>(1) R: Tape Reel (2) R24: SSOP-24, S24: SOP-24 (5) G: Halogen Free and Lead Free, L: Lead Free</p>
--	---

■ **MARKING**

SOP-24	SSOP-24

### ■ PIN CONFIGURATIONS

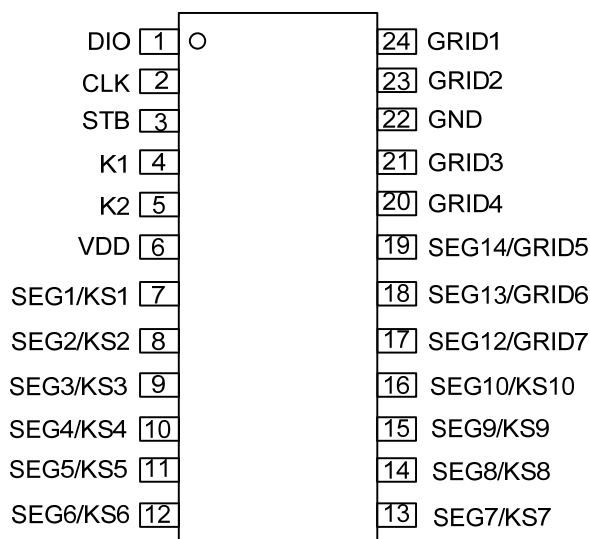

### ■ PIN CONFIGURATIONS

PIN NUMBER	SYMBOL	TYPE	FUNCTION
1	DIO	IN/OUT	Output serial data at falling edge of the shift clock, starting from lower bit. Input serial data is clocked in at rising edge of the shift clock, starting from lower bit.
2	CLK	IN	Reads serial data at rising edge, and outputs data at falling edge.
3	STB	IN	Initializes serial interface at rising or falling edge for reception of command. Data input after the falling edge of STB are processed as a command. While command data are processed, current processing is stopped, and the serial interface is initialized. While STB is high, instructions are ignored.
4	K1	IN	Key input
5	K2		
7 ~ 16	SEG1/KS1 ┆ SEG10/KS10	OUT	Segment output pin (dual function as key source)
17 ~ 19	SEG12/GRID7 ┆ SEG14/GRID5	OUT	Segment output pin (dual function as Digit output pin)
24,23,21,20	GRID1 ┆ GRID4	OUT	Digit output pin
6	V <sub>DD</sub>	PWR	5.0 V ± 10% Core main supply voltage. Bypass to GND through a 0.1 μF capacitor as close to the pin as possible
22	GND	PWR	Connect this pin to system GND

■ BLOCK DIAGRAM

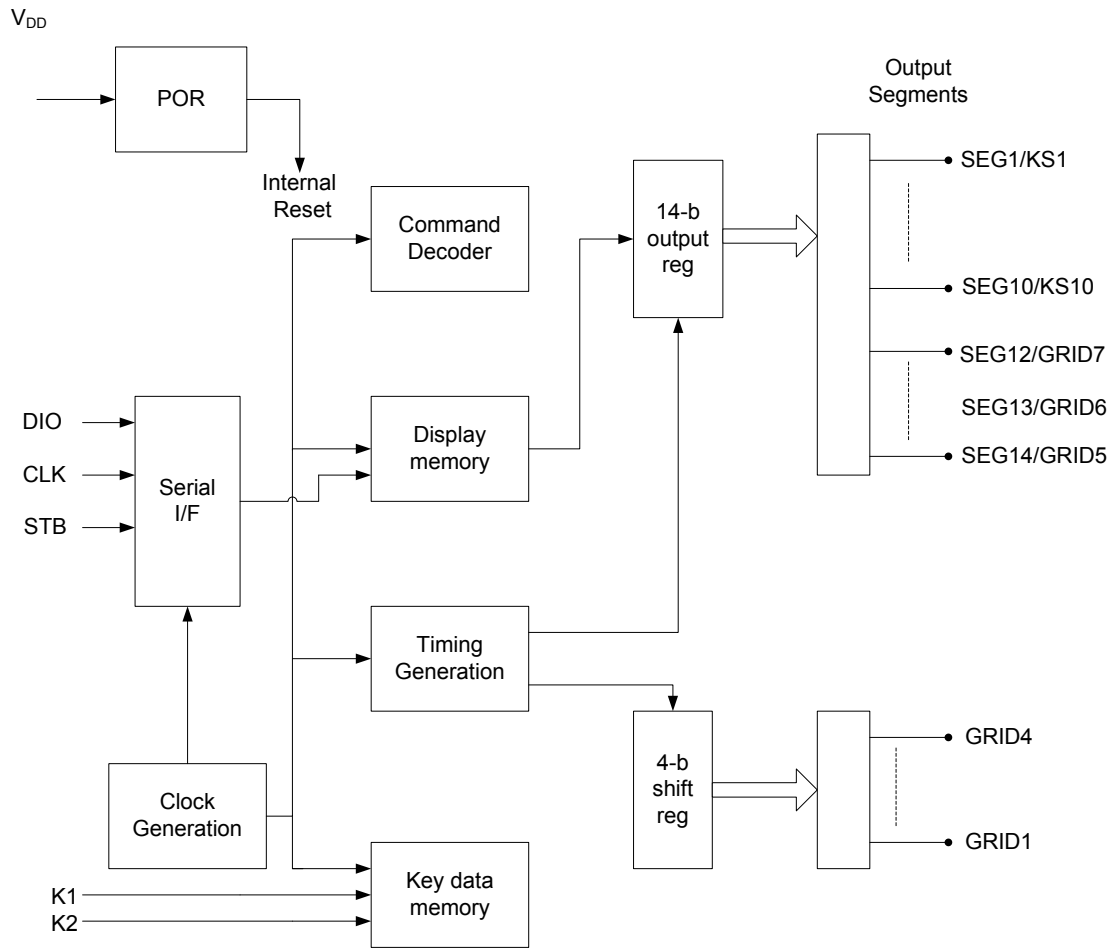

■ ABSOLUTE MAXIMUM RATINGS (all voltages are referenced to GND)

PARAMETER	SYMBOL	VALUES	UNIT
Supply Voltage to Ground	$V_{DD}$	7	V
Logic Input Voltage	$V_{IN}$	$V_{DD}$	V
Junction Temperature	$T_J$	+150	°C
Operating Ambient Temperature	$T_{OPR}$	-40 ~ +85	°C
Storage Temperature	$T_{STG}$	-65 ~ +150	°C

Note: Absolute maximum ratings are those values beyond which the device could be permanently damaged. Absolute maximum ratings are stress ratings only and functional device operation is not implied.

■ DC ELECTRICAL CHARACTERISTICS

DC electrical characteristics ( $T_A = -40$  to  $+85$  °C,  $V_{CC} = 5.0$  V  $\pm$  10%, GND = 0 V)

PARAMETER	SYMBOL	TEST CONDITIONS	MIN	TYP	MAX	UNIT
Logic Supply Voltage	$V_{DD}$		4.5	5.0	5.5	V
High Level Input Voltage	$V_{IH}$	High Level Guaranteed Digital Pins	$0.7 \times V_{DD}$		$V_{DD}$	V
Low Level Input Voltage	$V_{IL}$	Low Level Guaranteed Digital Pins	0		$0.3 \times V_{DD}$	V
Hysteresis Voltage (DIN, CLK, STB pins)	$V_{HYS}$			0.35		V
Low Level Output Voltage	$V_{OL(DOUT)}$	$D_{OUT}, I_{OL2}=4mA$			0.4	V
Segment Drive LED Source Current	$I_{OH}$	$V_O=V_{DD}-3V$	-40	-75	-110	mA
GRID Drive LED Sink Current	$I_{OL}$	$V_O=0.3V$	80	120		mA
Segment Drive Current Matching	$I_{TOLSEG}$	$V_{CC}=5.0V, T_A = 25^\circ C, V_{LED}=2.5V$		3		%

■ POWER SUPPLY CHARACTERISTICS ( $T_A = -40$  to  $+85$  °C, unless otherwise specified)

PARAMETER	SYMBOL	TEST CONDITIONS	MIN	TYP	MAX	UNIT
Quiescent Power Supply Current	$I_{STBY}$	$V_{DD}=5.0V$ , All Inputs= $V_{DD}$ or GND			1	mA
Operating Power Supply Current (display ON)	$I_{CC}$	All Segments ON, All Digits Scanned, Intensity Set to Full, Internal Oscillator, No Display Load Connected			5	mA

■ TIMING CHARACTERISTICS

( $T_A = -40$  ~  $+85$  °C,  $V_{CC}=5.0V \pm 10\%$ , Typical values are at 25 °C, unless otherwise specified)

PARAMETER	SYMBOL	TEST CONDITIONS	MIN	TYP	MAX	UNIT
Clock Pulse Width	$PW_{CLK}$			400		ns
Strobe Pulse Width	$PW_{STB}$			1		μs
Data Setup Time	$t_{SETUP}$			100		ns
Data Hold Time	$t_{HOLD}$	CLK Rising Edge to STB Rising Edge		100		ns
Clock-Strobe Time	$t_{CLK-STB}$			1		μs

### ■ TYPICAL APPLICATION CIRCUIT

#### UL318C driver total of anode digital screen hardware circuit

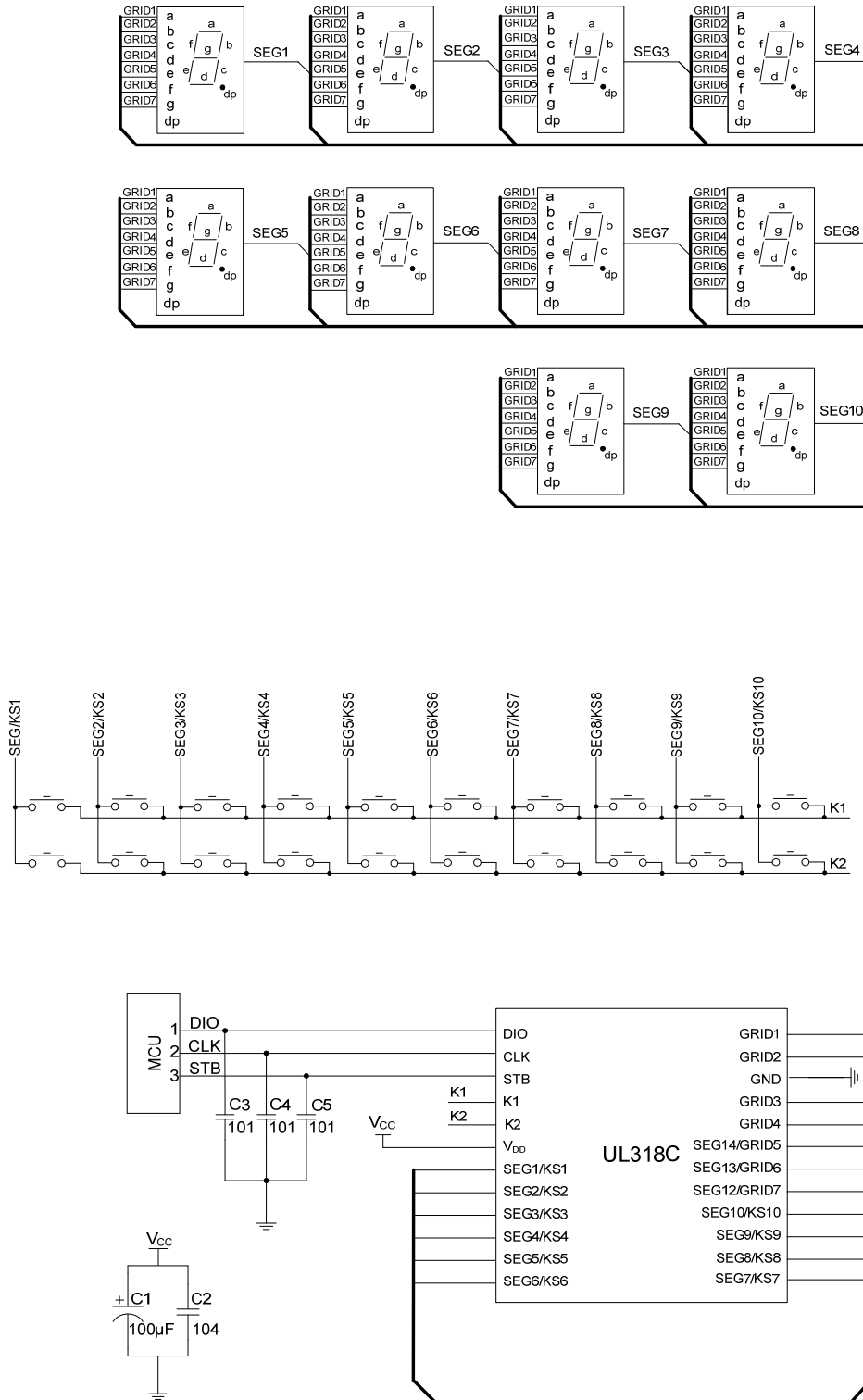

### ■ TYPICAL APPLICATION CIRCUIT (Cont.)

#### UL318C driver Common cathode digital screen hardware circuit

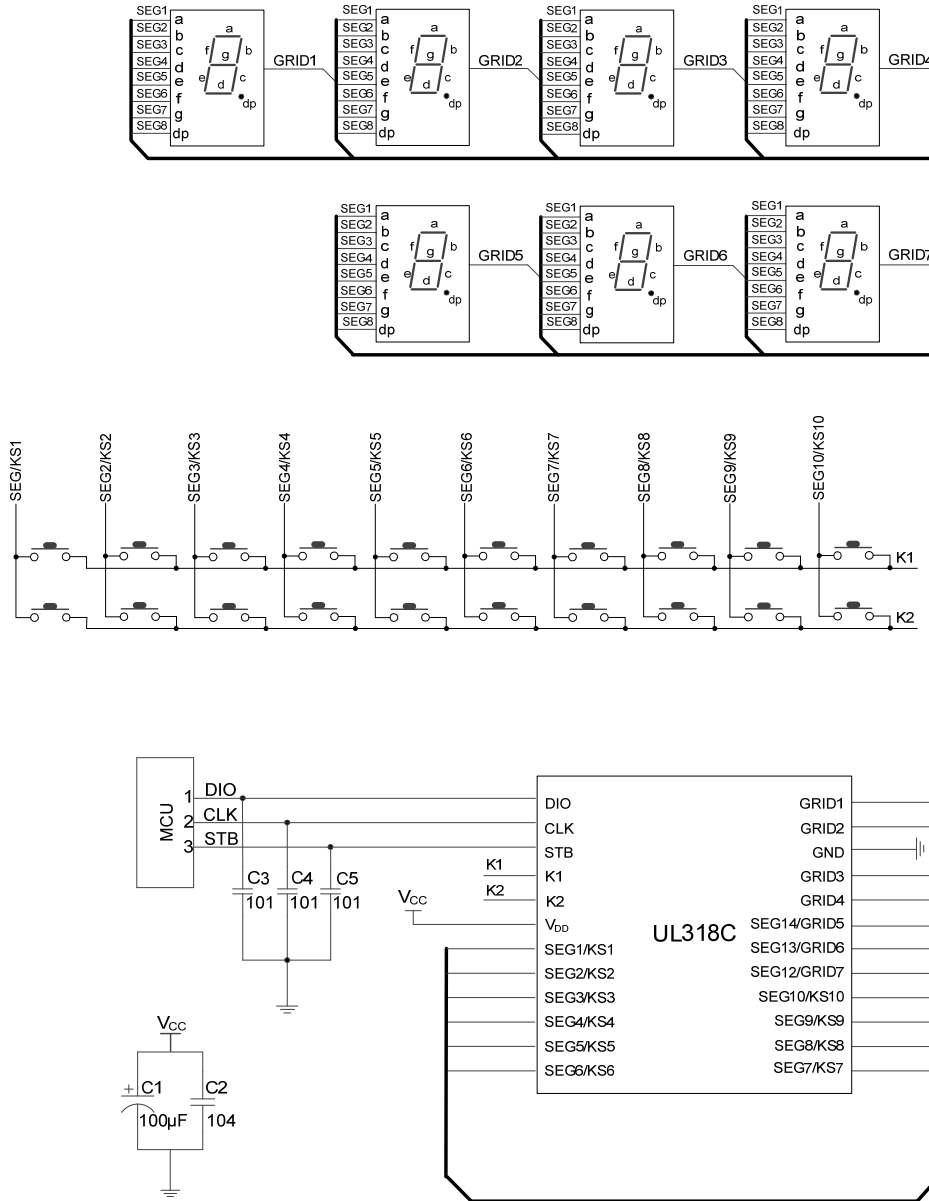

UTC assumes no responsibility for equipment failures that result from using products at values that exceed, even momentarily, rated values (such as maximum ratings, operating condition ranges, or other parameters) listed in products specifications of any and all UTC products described or contained herein. UTC products are not designed for use in life support appliances, devices or systems where malfunction of these products can be reasonably expected to result in personal injury. Reproduction in whole or in part is prohibited without the prior written consent of the copyright owner. UTC reserves the right to make changes to information published in this document, including without limitation specifications and product descriptions, at any time and without notice. This document supersedes and replaces all information supplied prior to the publication hereof.