



378RXXX

LINEAR INTEGRATED CIRCUIT

4 TERMINAL 3A OUTPUT LOW DROP VOLTAGE REGULATOR

DESCRIPTION

The UTC **378RXXX** Series are Low Drop Voltage Regulator suitable for various electronic equipments.

It provides constant voltage power source with TO-220-4 terminal lead full molded PKG. The Regulator has multi function such as over current protection, overheat protection and ON/OFF control.

FEATURES

- * 3.0A Output Low Drop Voltage Regulator.
- * Built in ON/OFF Control Terminal.
- * Built in Over Current Protection, Over Heat Protection Function.

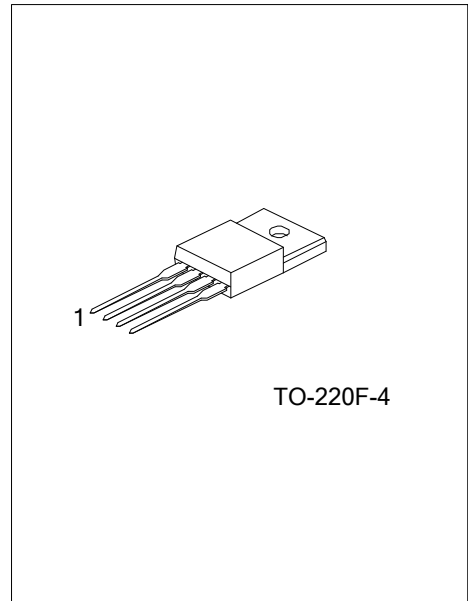

ORDERING INFORMATION

Ordering Number		Package	Packing
Lead Free	Halogen Free		
378RXXXL-TF4-T	378RXXXG-TF4-T	TO-220F-4	Tube

Note: xxx: Output Voltage, refer to Marking Information.

<p>378RXXXG-TF4-T</p>	<p>(1) Packing Type</p> <p>(2) Package Type</p> <p>(3) Lead Free</p> <p>(4) Voltage Code</p>	<p>(1) T: Tube</p> <p>(2) TF4: TO-220F-4</p> <p>(3) G: Halogen Free and Lead Free, L: Lead Free</p> <p>(4) xx: Refer to Marking Information</p>
-----------------------	--	---

MARKING INFORMATION

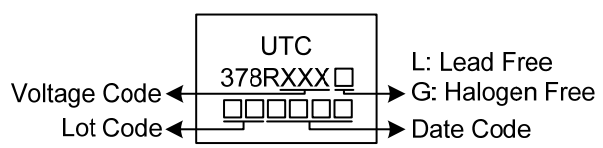
PACKAGE	VOLTAGE CODE	MARKING
TO-220F-4	1P5: 1.5V 1P8: 1.8V 3P3: 3.3V 05: 5.0V 06: 6.0V 08: 8.0V 09: 9.0V 10: 10V 12: 12V 15: 15V	 <p>UTC 378RXXX</p> <p>Voltage Code ← → Lot Code</p> <p>← → Date Code</p> <p>L: Lead Free G: Halogen Free</p>

PIN CONFIGURATION

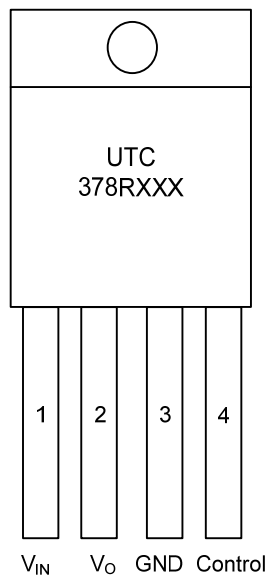

PIN DESCRIPTION

PIN NO.	PIN NAME	DESCRIPTION
1	V_{IN}	Input DC supply voltage
2	V_{OUT}	Output voltage pin
3	GND	Ground pin for the IC
4	Control	ON/OFF control pin

■ BLOCK DIAGRAM

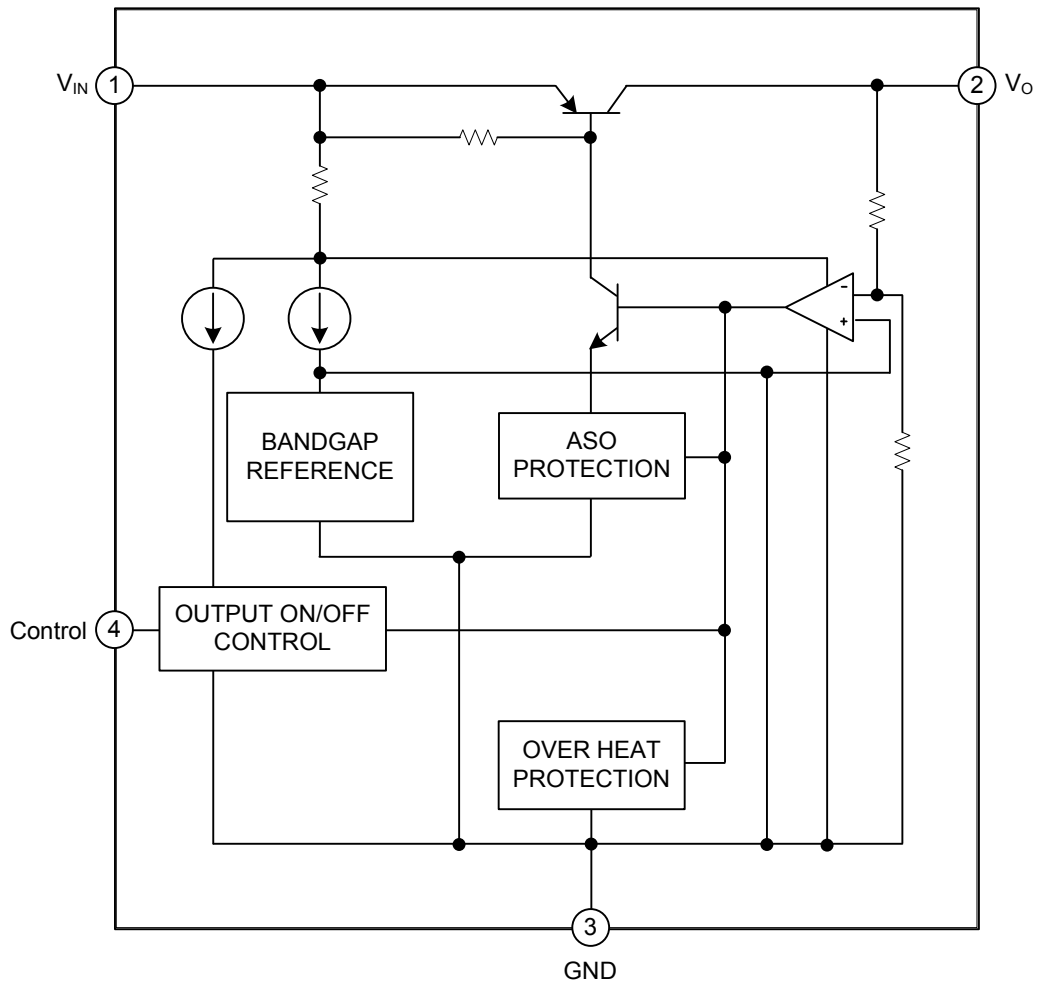

■ ABSOLUTE MAXIMUM RATING ($T_A=25^{\circ}\text{C}$, unless otherwise specified)

PARAMETER	SYMBOL	RATINGS	UNIT
Input Voltage	V_{IN}	35	V
ON/OFF Control Voltage	V_C	35	V
Output Current	I_O	3	A
Power Dissipation 1	P_{D1}	1.5	W
Junction Temperature	T_J	+150	$^{\circ}\text{C}$
Operating Temperature	T_{OPR}	-20 ~ +80	$^{\circ}\text{C}$
Storage Temperature	T_{STG}	-30 ~ +125	$^{\circ}\text{C}$

Note: Absolute maximum ratings are those values beyond which the device could be permanently damaged. Absolute maximum ratings are stress ratings only and functional device operation is not implied.

■ ELECTRICAL CHARACTERISTICS

(Unless otherwise specified, $I_O=1.0\text{A}$, $T_A = 25^{\circ}\text{C}$, unless otherwise specified)

For 378R1P5 ($V_{IN}=4.5\text{V}$)

PARAMETER	SYMBOL	TEST CONDITIONS	MIN	TYP	MAX	UNIT
Output Voltage	V_O		1.45	1.5	1.55	V
Load Regulation	Reg Load	$I_O=5\text{mA}\sim 3\text{A}$		0.1	2.0	%
Line Regulation	Reg Line	$V_{IN}=4.5\sim 8.5\text{V}$		0.5	2.5	%
Ripple Rejection	$R \cdot R$		45	55		dB
Drop Out Voltage (Note)	V_D	$I_O=3\text{A}$			3	V
Output ON State for Control Voltage	$V_{C(ON)}$		2.0			V
Output ON State for Control Current	$I_{C(ON)}$	$V_C=2.7\text{V}$			20	μA
Output OFF State for Control Voltage	$V_{C(OFF)}$				0.8	V
Output OFF State for Control Current	$I_{C(OFF)}$	$V_C=0.4\text{V}$			0.4	mA
Quiescent Current	I_Q	$I_O=0$			10	mA

For 378R1P8 ($V_{IN}=4.8\text{V}$)

PARAMETER	SYMBOL	TEST CONDITIONS	MIN	TYP	MAX	UNIT
Output Voltage	V_O		1.75	1.8	1.85	V
Load Regulation	Reg Load	$I_O=5\text{mA}\sim 3\text{A}$		0.1	2.0	%
Line Regulation	Reg Line	$V_{IN}=4.5\sim 9.0\text{V}$		0.5	2.5	%
Ripple Rejection	$R \cdot R$		45	55		dB
Drop Out Voltage (Note)	V_D	$I_O=3\text{A}$			2.7	V
Output ON State for Control Voltage	$V_{C(ON)}$		2.0			V
Output ON State for Control Current	$I_{C(ON)}$	$V_C=2.7\text{V}$			20	μA
Output OFF State for Control Voltage	$V_{C(OFF)}$				0.8	V
Output OFF State for Control Current	$I_{C(OFF)}$	$V_C=0.4\text{V}$			0.4	mA
Quiescent Current	I_Q	$I_O=0$			10	mA

For 378R3P3 ($V_{IN}=5\text{V}$)

PARAMETER	SYMBOL	TEST CONDITIONS	MIN	TYP	MAX	UNIT
Output Voltage	V_O		3.22	3.3	3.38	V
Load Regulation	Reg Load	$I_O=5\text{mA}\sim 3\text{A}$		0.1	2.0	%
Line Regulation	Reg Line	$V_{IN}=4.5\sim 10\text{V}$		0.5	2.5	%
Ripple Rejection	$R \cdot R$		45	55		dB
Drop Out Voltage (Note)	V_D	$I_O=3\text{A}$			0.8	V
Output ON State for Control Voltage	$V_{C(ON)}$		2.0			V
Output ON State for Control Current	$I_{C(ON)}$	$V_C=2.7\text{V}$			20	μA
Output OFF State for Control Voltage	$V_{C(OFF)}$				0.8	V
Output OFF State for Control Current	$I_{C(OFF)}$	$V_C=0.4\text{V}$			0.4	mA
Quiescent Current	I_Q	$I_O=0$			10	mA

■ ELECTRICAL CHARACTERISTICS (Cont.)

For 378R05 ($V_{IN}=7V$)

PARAMETER	SYMBOL	TEST CONDITIONS	MIN	TYP	MAX	UNIT
Output Voltage	V_O		4.88	5.0	5.12	V
Load Regulation	Reg Load	$I_O=5mA\sim 3A$		0.1	2.0	%
Line Regulation	Reg Line	$V_{IN}=6\sim 12V$		0.5	2.5	%
Ripple Rejection	$R \cdot R$		45	55		dB
Drop Out Voltage (Note)	V_D	$I_O=3A$			0.8	V
Output ON State for Control Voltage	$V_{C(ON)}$		2.0			V
Output ON State for Control Current	$I_{C(ON)}$	$V_C=2.7V$			20	μA
Output OFF State for Control Voltage	$V_{C(OFF)}$				0.8	V
Output OFF State for Control Current	$I_{C(OFF)}$	$V_C=0.4V$			0.4	mA
Quiescent Current	I_Q	$I_O=0$			10	mA

For 378R06 ($V_{IN}=8V$)

PARAMETER	SYMBOL	TEST CONDITIONS	MIN	TYP	MAX	UNIT
Output Voltage	V_O		5.85	6.0	6.15	V
Load Regulation	Reg Load	$I_O=5mA\sim 3A$		0.1	2.0	%
Line Regulation	Reg Line	$V_{IN}=7\sim 13V$		0.5	2.5	%
Ripple Rejection	$R \cdot R$		45	55		dB
Drop Out Voltage (Note)	V_D	$I_O=3A$			0.8	V
Output ON State for Control Voltage	$V_{C(ON)}$		2.0			V
Output ON State for Control Current	$I_{C(ON)}$	$V_C=2.7V$			20	μA
Output OFF State for Control Voltage	$V_{C(OFF)}$				0.8	V
Output OFF State for Control Current	$I_{C(OFF)}$	$V_C=0.4V$			0.4	mA
Quiescent Current	I_Q	$I_O=0$			10	mA

For 378R08 ($V_{IN}=10V$)

PARAMETER	SYMBOL	TEST CONDITIONS	MIN	TYP	MAX	UNIT
Output Voltage	V_O		7.80	8.0	8.20	V
Load Regulation	Reg Load	$I_O=5mA\sim 3A$		0.1	2.0	%
Line Regulation	Reg Line	$V_{IN}=9\sim 25V$		0.5	2.5	%
Ripple Rejection	$R \cdot R$		45	55		dB
Drop Out Voltage (Note)	V_D	$I_O=3A$			0.8	V
Output ON State for Control Voltage	$V_{C(ON)}$		2.0			V
Output ON State for Control Current	$I_{C(ON)}$	$V_C=2.7V$			20	μA
Output OFF State for Control Voltage	$V_{C(OFF)}$				0.8	V
Output OFF State for Control Current	$I_{C(OFF)}$	$V_C=0.4V$			0.4	mA
Quiescent Current	I_Q	$I_O=0$			10	mA

For 378R09 ($V_{IN}=15V$)

PARAMETER	SYMBOL	TEST CONDITIONS	MIN	TYP	MAX	UNIT
Output Voltage	V_O		8.78	9.0	9.22	V
Load Regulation	Reg Load	$I_O=5mA\sim 3A$		0.1	2.0	%
Line Regulation	Reg Line	$V_{IN}=10\sim 25V$		0.5	2.5	%
Ripple Rejection	$R \cdot R$		45	55		dB
Drop Out Voltage (Note)	V_D	$I_O=3A$			0.8	V
Output ON State for Control Voltage	$V_{C(ON)}$		2.0			V
Output ON State for Control Current	$I_{C(ON)}$	$V_C=2.7V$			20	μA
Output OFF State for Control Voltage	$V_{C(OFF)}$				0.8	V
Output OFF State for Control Current	$I_{C(OFF)}$	$V_C=0.4V$			0.4	mA
Quiescent Current	I_Q	$I_O=0$			10	mA

■ ELECTRICAL CHARACTERISTICS (Cont.)

For 378R10 ($V_{IN}=16V$)

PARAMETER	SYMBOL	TEST CONDITIONS	MIN	TYP	MAX	UNIT
Output Voltage	V_O		9.75	10.0	10.25	V
Load Regulation	Reg Load	$I_O=5mA\sim 3A$		0.1	2.0	%
Line Regulation	Reg Line	$V_{IN}=11\sim 26V$		0.5	2.5	%
Ripple Rejection	$R \cdot R$		45	55		dB
Drop Out Voltage (Note)	V_D	$I_O=3A$			0.8	V
Output ON State for Control Voltage	$V_{C(ON)}$		2.0			V
Output ON State for Control Current	$I_{C(ON)}$	$V_C=2.7V$			20	μA
Output OFF State for Control Voltage	$V_{C(OFF)}$				0.8	V
Output OFF State for Control Current	$I_{C(OFF)}$	$V_C=0.4V$			0.4	mA
Quiescent Current	I_Q	$I_O=0$			10	mA

For 378R12 ($V_{IN}=18V$)

PARAMETER	SYMBOL	TEST CONDITIONS	MIN	TYP	MAX	UNIT
Output Voltage	V_O		11.70	12.0	12.30	V
Load Regulation	Reg Load	$I_O=5mA\sim 3A$		0.1	2.0	%
Line Regulation	Reg Line	$V_{IN}=13\sim 29V$		0.5	2.5	%
Ripple Rejection	$R \cdot R$		45	55		dB
Drop Out Voltage (Note)	V_D	$I_O=3A$			0.8	V
Output ON State for Control Voltage	$V_{C(ON)}$		2.0			V
Output ON State for Control Current	$I_{C(ON)}$	$V_C=2.7V$			20	μA
Output OFF State for Control Voltage	$V_{C(OFF)}$				0.8	V
Output OFF State for Control Current	$I_{C(OFF)}$	$V_C=0.4V$			0.4	mA
Quiescent Current	I_Q	$I_O=0$			10	mA

For 378R15 ($V_{IN}=21V$)

PARAMETER	SYMBOL	TEST CONDITIONS	MIN	TYP	MAX	UNIT
Output Voltage	V_O		14.70	15.0	15.30	V
Load Regulation	Reg Load	$I_O=5mA\sim 3A$		0.1	2.0	%
Line Regulation	Reg Line	$V_{IN}=16\sim 32V$		0.5	2.5	%
Ripple Rejection	$R \cdot R$		45	55		dB
Drop Out Voltage (Note)	V_D	$I_O=3A$			0.8	V
Output ON State for Control Voltage	$V_{C(ON)}$		2.0			V
Output ON State for Control Current	$I_{C(ON)}$	$V_C=2.7V$			20	μA
Output OFF State for Control Voltage	$V_{C(OFF)}$				0.8	V
Output OFF State for Control Current	$I_{C(OFF)}$	$V_C=0.4V$			0.4	mA
Quiescent Current	I_Q	$I_O=0$			10	mA

Note: Input voltage shall be the value when output voltage is 95% in comparison with the initial value.

■ TEST CIRCUIT

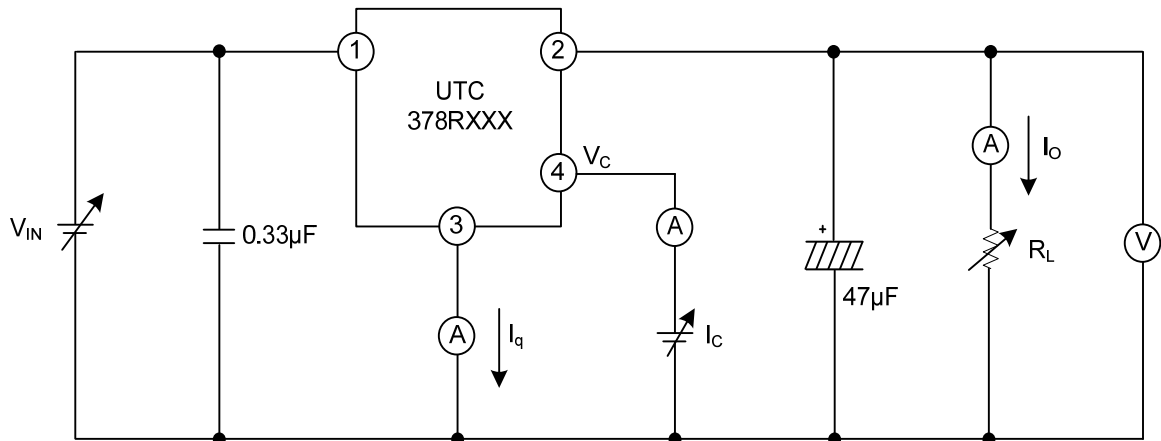

Standard Test Circuit

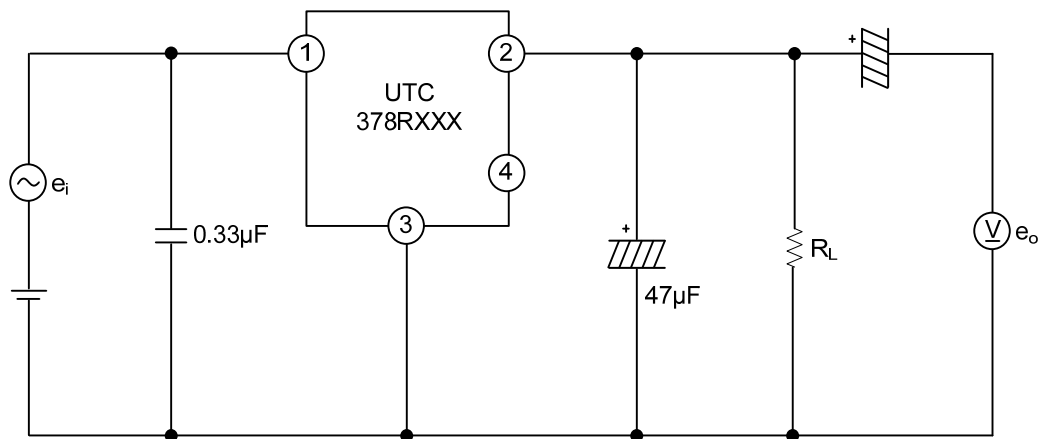

f=120Hz (sine wave)
 $e_i=0.5V_{rms}$
 $RR=20\log(e_i/e_o)$

Ripple Rejection Test Circuit

■ TYPICAL APPLICATION CIRCUIT

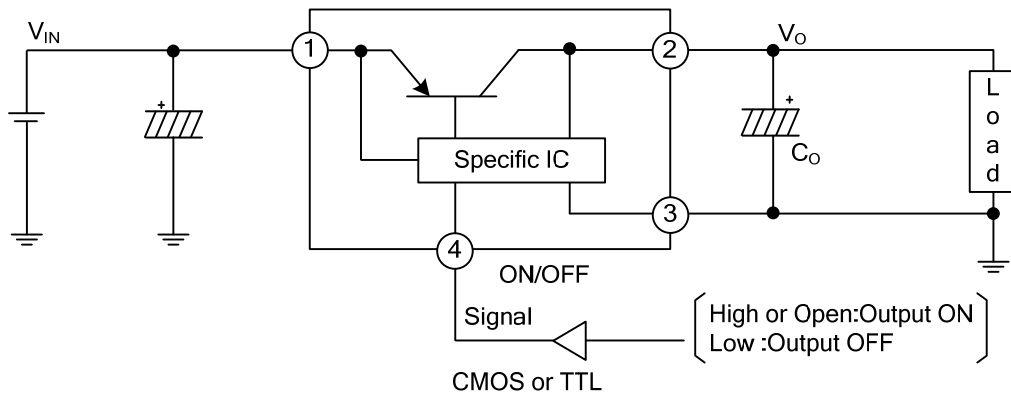

Application Circuit Standard

UTC assumes no responsibility for equipment failures that result from using products at values that exceed, even momentarily, rated values (such as maximum ratings, operating condition ranges, or other parameters) listed in products specifications of any and all UTC products described or contained herein. UTC products are not designed for use in life support appliances, devices or systems where malfunction of these products can be reasonably expected to result in personal injury. Reproduction in whole or in part is prohibited without the prior written consent of the copyright owner. UTC reserves the right to make changes to information published in this document, including without limitation specifications and product descriptions, at any time and without notice. This document supersedes and replaces all information supplied prior to the publication hereof.