



UD24301

Advance

LINEAR INTEGRATED CIRCUIT

FAST TURN-OFF INTELLIGENT CONVERTER

DESCRIPTION

The UTC **UD24301** is a high frequency synchronous rectified step-down switch mode converter with built in internal power MOSFETs. It offers a very compact solution to achieve 3A continuous output current over a wide input supply range with excellent load and line regulation. The UTC **UD24301** has synchronous mode operation for higher efficiency over output current load range.

Current mode operation provides fast transient response and eases loop stabilization.

Full protection features include OCP and thermal shut down.

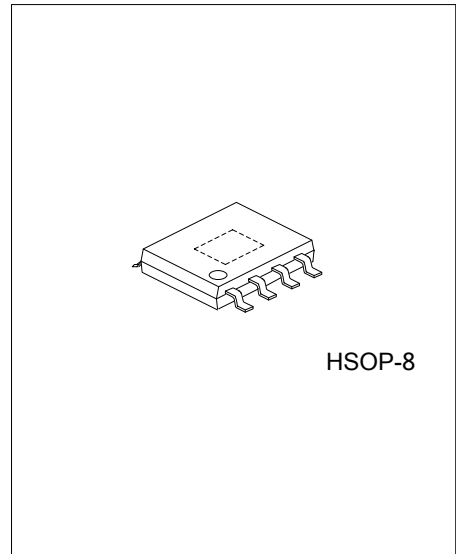

HSOP-8

FEATURES

- * Wide 4.5V to 24V Operating Input Range
- * 3A Load Current
- * 90mΩ / 40mΩ Low R_{DS(ON)} Internal Power MOSFETs
- * Low Quiescent Current
- * High Efficiency Synchronous Mode Operation
- * Fixed 500kHz Switching Frequency
- * Frequency Sync from 200kHz to 2MHz External Clock
- * AAM Power Save Mode
- * Internal Soft Start
- * OCP Protection and Hiccup
- * Thermal Shutdown
- * Output Adjustable from 0.8V

ORDERING INFORMATION

Ordering Number		Package	Packing
Lead Free	Halogen Free		
UD24301L-SH2-R	UD24301G-SH2-R	HSOP-8	Tape Reel

<p>UD24301G-SH2-R</p> <p>(1)Packing Type</p> <p>(2)Package Type</p> <p>(3)Green Package</p>	<p>(1) R: Tape Reel</p> <p>(2) SH2: HSOP-8</p> <p>(3) G: Halogen Free and Lead Free, L: Lead Free</p>
---	---

MARKING

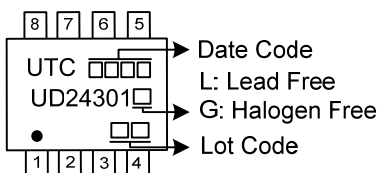

■ PIN CONFIGURATION

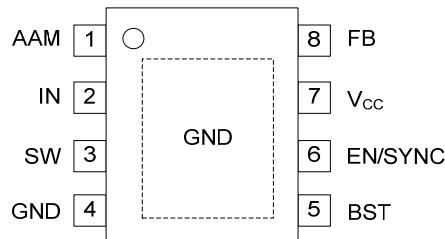

■ PIN DESCRIPTION

PIN NO.	PIN NAME	DESCRIPTION
1	AAM	A resistor is connected from AAM pin to ground to set a AAM voltage force UTC UD24301 into non-synchronous mode when load is small. Drive AAM pin high (=V _{CC}) will force UTC UD24301 into CCM.
2	IN	Supply Voltage. The UTC UD24301 operates from a +4.5V to +24V input rail. C1 is needed to decouple the input rail. Use wide PCB trace to make the connection.
3	SW	Switch Output. Use wide PCB trace to make the connection.
4	GND	System Ground. This pin is the reference ground of the regulated output voltage. For this reason care must be taken in PCB layout. Suggested to be connected to GND with copper and vias.
5	BST	Bootstrap. A capacitor and a 20 Ω resistor connected between SW and BST pins are required to form a floating supply across the high-side switch driver.
6	EN/SYNC	EN=1 to enable the UTC UD24301 . External clock can be applied to EN pin for changing switching frequency.
7	V _{CC}	Bias Supply. Decouple with 0.1μF-0.22μF cap. And the capacitance should be no more than 0.22μF
8	FB	Feedback. An external resistor divider from the output to the FB pin, sets the output voltage. To prevent current limit run away during a short circuit fault condition the frequency fold-back comparator lowers the oscillator frequency when the FB voltage is below 400mV.

■ BLOCK DIAGRAM

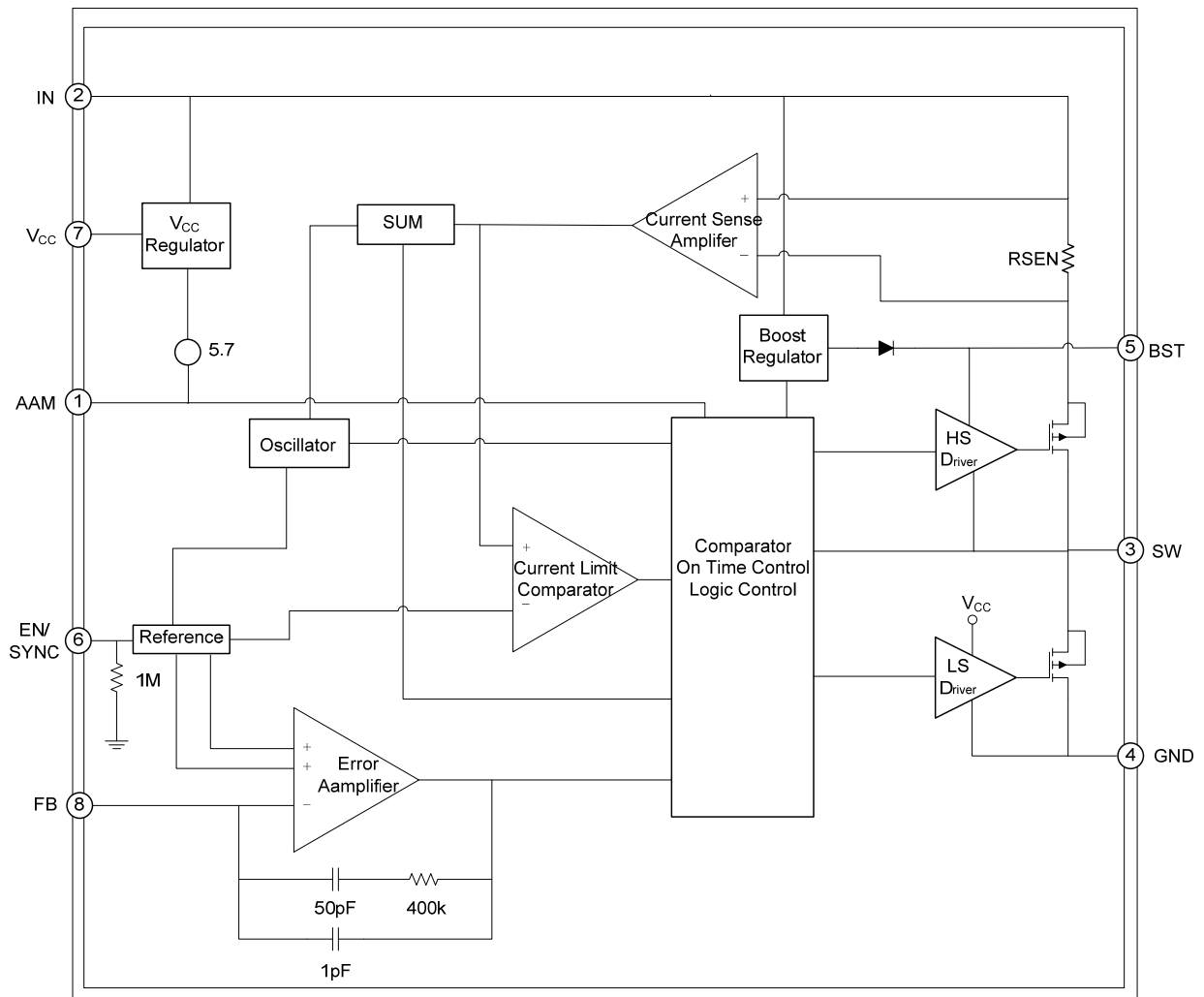

■ ABSOLUTE MAXIMUM RATING

PARAMETER	SYMBOL	RATINGS	UNIT
Input Supply Voltage	V_{IN}	26	V
SW Voltage	V_{SW}	0.3	V
Boost Voltage	V_{BST}	$V_{SW}+6$	V
All Other Pins Voltage		6	V
Junction Temperature	T_J	+150	°C
Storage Temperature	T_{STG}	-65 ~ +150	°C

Note: Absolute maximum ratings are those values beyond which the device could be permanently damaged. Absolute maximum ratings are stress ratings only and functional device operation is not implied.

■ RECOMMENDED OPERATING CONDITIONS

PARAMETER	SYMBOL	RATINGS	UNIT
Input Supply Voltage	V_{IN}	4.5 ~ 24	V
Output Voltage	V_{OUT}	$0.8V \sim V_{IN}-3$	V
Ambient Temperature	T_A	-40 ~ +125	°C

Note: If out of its operation conditions, the device is not guaranteed to function.

■ THERMAL DATA

PARAMETER	SYMBOL	RATINGS	UNIT
Junction To Ambient	θ_{JA}	143	°C/W
Junction to Case	θ_{JC}	50	°C/W

■ ELECTRICAL CHARACTERISTICS ($V_{IN}=12V$, $T_A=25^\circ C$, unless otherwise specified)

PARAMETER	SYMBOL	TEST CONDITIONS	MIN	TYP	MAX	UNIT
Supply Current (Shutdown)	I_{IN}	$V_{EN}=0V$			1	μA
Supply Current(Quiescent)	I_Q	$V_{EN}=2V$, $V_{FB}=1V$, $A_{AM}=0.5V$		0.17	1	mA
HS Switch On Resistance	HS $R_{DS(ON)}$	$V_{BST}-S_W=5V$		90		m Ω
LS Switch On Resistance	LS $R_{DS(ON)}$	$V_{CC}=5V$		40		m Ω
Switch Leakage	SW I_{LKG}	$V_{EN}=0V$, $V_{SW}=12V$			1	μA
Current Limit	I_{LIMIT}	Duty Cycle=40%	5.6	6.6	7.6	A
Oscillator Frequency	f_{SW}	$V_{FB}=750mV$	440	500	580	kHz
Fold-back Frequency	f_{FB}	$V_{FB}<400mV$		0.5		f_{SW}
Maximum Duty Cycle	D_{MAX}	$V_{FB}=700mV$	90	95		%
Minimum On Time	T_{ON_MIN}			60		ns
Sync Frequency Range	f_{SYNC}		0.2		2	MHz
Feedback Voltage	V_{FB}		772	788	804	mV
Feedback Current	I_{FB}	$V_{FB}=820mV$		10	50	nA
EN Rising Threshold	V_{EN_RISING}		1.2	1.4	1.6	V
EN Falling Threshold	$V_{EN_FALLING}$		1.1	1.25	1.4	V
EN Input Current	I_{EN}	$V_{EN}=2V$ $V_{EN}=0V$		2 0		μA
EN Turn Off Delay	$E_{NTd-off}$			8		μs
V_{IN} Under Voltage Lockout Threshold-Rising	I_{NUVth}		3.7	3.9	4.1	V
V_{IN} Under Voltage Lockout Threshold-Hysteresis	I_{NUVHYS}			650		mV
Regulator V_{CC}	V_{CC}			5		V
Load Regulation	V_{CC}	$I_{CC}=5mA$		3		%
Soft-Start Period	T_{SS}	$3V < V_G < 10V$	1	1.5	2	ms
Thermal Shutdown				170		°C
Thermal Shutdown hysteresis				50		°C

■ FUNCTION DESCRIPTION

The UTC **UD24301** is a high frequency synchronous rectified step-down switch mode converter with built in internal power MOSFETs. It offers a very compact solution to achieve 3A continuous output current over a wide input supply range with excellent load and line regulation.

The UTC **UD24301** operates in a fixed frequency, peak current control mode to regulate the output voltage. A PWM cycle is initiated by the internal clock. The integrated high-side power MOSFET is turned on and remains on until its current reaches the value set by the COMP voltage. When the power switch is off, it remains off until the next clock cycle starts. If, in 95% of one PWM period, the current in the power MOSFET does not reach the COMP set current value, the power MOSFET will be forced to turn off.

■ DETAILED DESCRIPTION

Internal Regulator

Most of the internal circuitries are powered from the 5V internal regulator. This regulator takes the V_{IN} input and operates in the full V_{IN} range. When V_{IN} is greater than 5V, the output of the regulator is in full regulation. When V_{IN} is lower than 5V, the output decreases, a 0.1 μ F ceramic capacitor for decoupling purpose is required.

Error Amplifier

The error amplifier compares the FB pin voltage with the internal 0.8V reference (REF) and outputs a COMP voltage, which is used to control the power MOSFET current. The optimized internal compensation network minimizes the external component counts and simplifies the control loop design.

Enable/SYNC control

EN is a digital control pin that turns the regulator on and off. Drive EN high to turn on the regulator, drive it low to turn it off. There is an internal 1MEG resistor from EN to GND thus EN can be floated to shut down the chip. Also EN pin voltage was clamped to around 6.5V by an internal zener-diode. Please use large enough pull up resistor connecting between V_{IN} and EN to limit the EN input current which should be less than 100 μ A. Generally, around 100k resistor should be large enough for all the applications.

The chip can be synchronized to external clock range from 200kHz up to 2MHz through this pin 2ms right after output voltage is set, with the internal clock rising edge synchronized to the external clock rising edge.

Under-Voltage Lockout (UVLO)

Under-voltage lockout (UVLO) is implemented to protect the chip from operating at insufficient supply voltage. The UTC **UD24301** UVLO comparator monitors the output voltage of the internal regulator, V_{CC} . The UVLO rising threshold is about 3.9V while its falling threshold is consistent 3.25V.

Internal Soft-Start

The soft start is implemented to prevent the converter output voltage from overshooting during start up. When the chip starts, the internal circuitry generates a soft-start voltage (SS) ramping up from 0V. The soft-start period lasts until the voltage on the soft-start capacitor exceeds the reference voltage of 0.8V. At this point the reference voltage takes over. The soft-start time is internally set to be around 1.5ms.

Over-Current-Protection and Hiccup

The UTC **UD24301** has cycle-by-cycle over current limit when the inductor current peak value exceeds the set current limit threshold. Meanwhile, output voltage starts to drop until FB is below the Under-Voltage (UV) threshold, typically 50% below the reference. Once a UV is triggered, the UTC **UD24301** enters hiccup mode to periodically restart the part. This protection mode is especially useful when the output is dead-short to ground. The average short circuit current is greatly reduced to alleviate the thermal issue and to protect the regulator. The UTC **UD24301** exits the hiccup mode once the over current condition is removed.

Thermal Shutdown

Thermal shutdown is implemented to prevent the chip from operating at exceedingly high temperatures. When the silicon die temperature is higher than 150°C, it shuts down the whole chip. When the temperature is lower than its lower threshold, typically 130°C, the chip is enabled again.

■ DETAILED DESCRIPTION (Cont.)

Floating Driver and Bootstrap Charging

The floating power MOSFET driver is powered by an external bootstrap capacitor. This floating driver has its own UVLO protection. This UVLO's rising threshold is 2.2V with a hysteresis of 150mV. The bootstrap capacitor voltage is regulated internally by V_{IN} through D1, R5, C5, L1 and C2. If $(V_{IN}-V_{SW})$ is more than 5V, U2 will regulate M3 to maintain a 5V BST voltage across C5

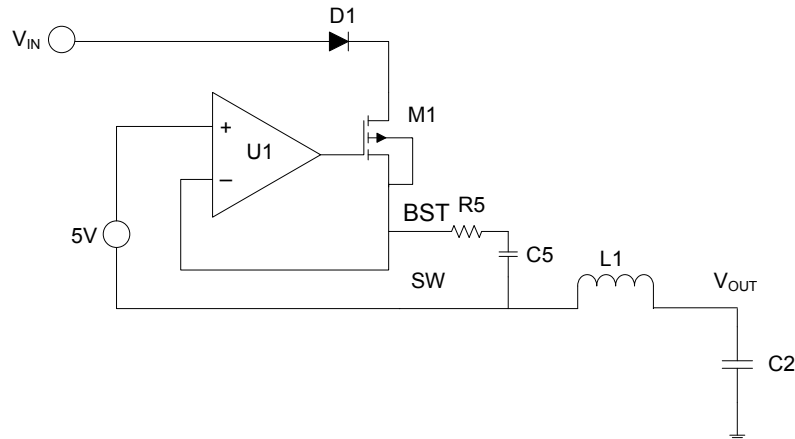

If both V_{IN} and EN are higher than their appropriate thresholds, the chip starts. The reference block starts first, generating stable reference voltage and currents, and then the internal regulator is enabled. The regulator provides stable supply for the remaining circuitries.

Three events can shut down the chip: EN low, V_{IN} low and thermal shutdown. In the shutdown procedure, the signaling path is first blocked to avoid any fault triggering. The COMP voltage and the internal supply rail are then pulled down. The floating driver is not subject to this shutdown command.

■ TYPICAL APPLICATION CIRCUIT

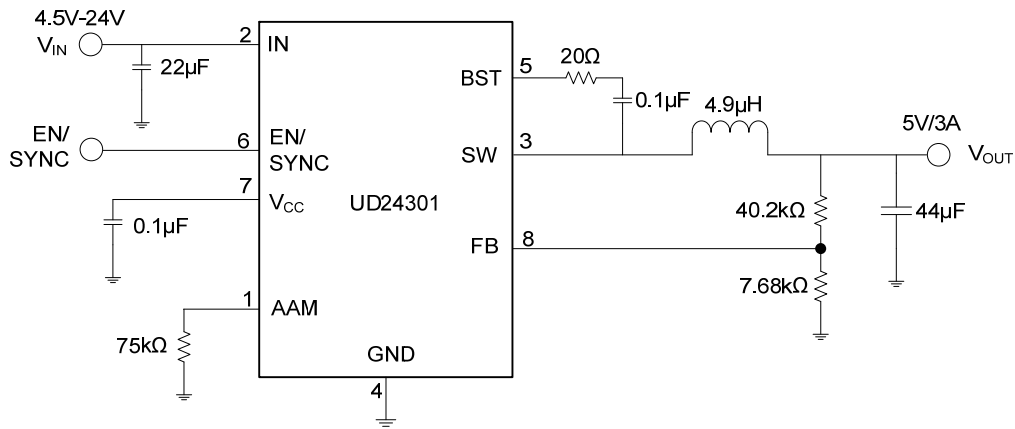

UTC assumes no responsibility for equipment failures that result from using products at values that exceed, even momentarily, rated values (such as maximum ratings, operating condition ranges, or other parameters) listed in products specifications of any and all UTC products described or contained herein. UTC products are not designed for use in life support appliances, devices or systems where malfunction of these products can be reasonably expected to result in personal injury. Reproduction in whole or in part is prohibited without the prior written consent of the copyright owner. UTC reserves the right to make changes to information published in this document, including without limitation specifications and product descriptions, at any time and without notice. This document supersedes and replaces all information supplied prior to the publication hereof.