



U74LVC2T45

Preliminary

CMOS IC

DUAL-BIT DUAL-SUPPLY BUS TRANSCEIVER WITH CONFIGURABLE VOLTAGE TRANSLATION

■ DESCRIPTION

This dual-bit noninverting bus transceiver uses two separate configurable power-supply rails. The A port is designed to track V_{CCA} . V_{CCA} accepts any supply voltage from 1.65V to 5.5V. The B port is designed to track V_{CCB} . V_{CCB} accepts any supply voltage from 1.65V to 5.5V. This allows for universal low Voltage bidirectional translation between any of the 1.8V, 2.5V, 3.3V, and 5V voltage nodes.

The **U74LVC2T45** is designed for asynchronous communication between two data buses. The logic levels of the direction-control (DIR) input activate either the B-port outputs or the A-port outputs. The device transmits data from the A bus to the B bus when the B-port outputs are activated, and from the B bus to the A bus when the A-port outputs are activated. The input circuitry on both A and B ports always is active and must have a logic HIGH or LOW level applied to prevent excess I_{CC} and I_{CCZ} .

The **U74LVC2T45** is designed so that the DIR input circuit is supplied by V_{CCA} . This device is fully specified for partial-power-down applications using I_{OFF} . The I_{OFF} circuitry disables the outputs, preventing damaging current backflow through the device when it is powered down.

The V_{CC} isolation feature ensures that if either V_{CC} input is at GND, both ports are in the high-impedance state.

■ FEATURES

- * Fully Configurable Dual-Rail Design Allows Each Port to Operate Over the Full 1.65-V to 5.5-V Power-Supply Range
- * V_{CC} Isolation Feature: If Either V_{CC} Input Is at GND, Both Ports Are in the High-Impedance State
- * $\pm 24\text{mA}$ Output Drive at 3.3V
- * I_{OFF} Supports Partial-Power-Down Mode Operation

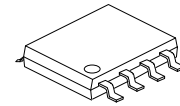

SOP-8

■ ORDERING INFORMATION

Ordering Number		Package	Packing
Lead Free	Halogen Free		
U74LVC2T45L-S08-R	U74LVC2T45G-S08-R	SOP-8	Tape Reel

<p>U74LVC2T45G-S08-R</p>	<p>(1) Packing Type (1) R: Tape Reel</p> <p>(2) Package Type (2) S08: SOP-8</p> <p>(3) Green Package (3) G: Halogen Free and Lead Free, L: Lead Free</p>
--------------------------	--

■ MARKING

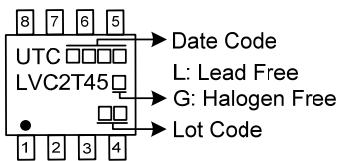

■ PIN CONFIGURATION

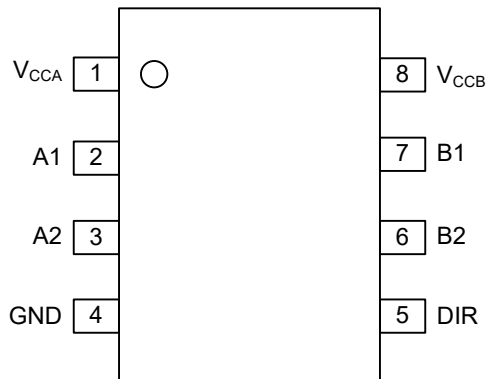

■ PIN DESCRIPTION

PIN NO.	PIN NAME	I/O	DESCRIPTION
1	V _{CCA}	P	A-portsupplyvoltage. $1.65V \leq V_{CCA} \leq 5.5V$
2	A1	I/O	Input/output A1.Referencedto V _{CCA}
3	A2	I/O	Input/output A2.Referencedto V _{CCA}
4	GND	G	Ground
5	DIR	I	Direction control signal
6	B2	I/O	Input/output B2.Referencedto V _{CCB}
7	B1	I/O	Input/output B1.Referencedto V _{CCB}
8	V _{CCB}	P	B-portsupplyvoltage. $1.65V \leq V_{CCB} \leq 5.5V$

Note: P=Power, G=Ground, I/O=Input and output, I=Input

■ FUNCTION TABLE

INPUTS DIR	OPERATION
L	B data to A bus
H	A data to B bus

■ LOGIC DIAGRAM (POSITIVE LOGIC)

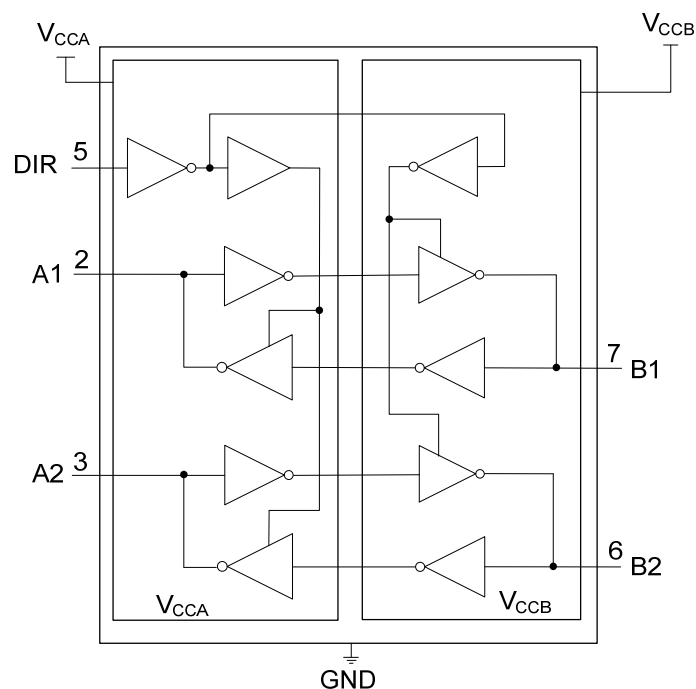

■ ABSOLUTE MAXIMUM RATING

PARAMETER	SYMBOL	TEST CONDITIONS	RATINGS	UNIT
Supply Voltage	V_{CCA}		-0.5 ~ 6.5	V
Supply Voltage	V_{CCB}		-0.5 ~ 6.5	V
Input Voltage (Note 2)	V_{IN}	A Port	-0.5 ~ 6.5	V
		B Port	-0.5 ~ 6.5	V
		Control Input	-0.5 ~ 6.5	V
Voltage applied to any output in the high-impedance or power off state (Note 2)	V_{OUT}	A Port	-0.5 ~ 6.5	V
		B Port	-0.5 ~ 6.5	V
Voltage applied to any output in the high or low state (Note 2, 3)	V_{OUT}	A Port	-0.5 ~ $V_{CCA}+0.5$	V
		B Port	-0.5 ~ $V_{CCB}+0.5$	V
Continuous Output Current	I_{OUT}		±50	mA
Continuous current through V_{CCA} , V_{CCB} or GND			±100	mA
Input Clamp Current	I_{IK}	$V_{IN} < 0V$	-50	mA
Output Clamp Current	I_{OK}	$V_{OUT} < 0V$	-50	mA
Storage Temperature Range	T_{STG}		-65 ~ +150	°C

- Notes: 1. Absolute maximum ratings are those values beyond which the device could be permanently damaged. Absolute maximum ratings are stress ratings only and functional device operation is not implied.
2. The input negative-voltage and output voltage ratings may be exceeded if the input and output current ratings are observed.
3. The value of V_{CC} is provided in the recommended operating conditions table.

RECOMMENDED OPERATING CONDITIONS

PARAMETER		SYMBOL	TEST CONDITIONS	MIN	TYP	MAX	UNIT	
Supply Voltage		V_{CCA}		1.65		5.5	V	
Supply Voltage		V_{CCB}		1.65		5.5	V	
High-Level Input Voltage	Data Inputs (Note 1)	V_{IH}	$V_{CCI}=1.65V\sim 1.95V$	V_{CCI} $\times 0.65$			V	
			$V_{CCI}=2.3V\sim 2.7V$	1.7			V	
			$V_{CCI}=3V\sim 3.6V$	2			V	
			$V_{CCI}=4.5V\sim 5.5V$	V_{CCI} $\times 0.7$			V	
	DIR (Referenced to V_{CCA}) (Note 2)		$V_{CCI}=1.65V\sim 1.95V$	V_{CCA} $\times 0.65$				V
			$V_{CCI}=2.3V\sim 2.7V$	1.7				V
			$V_{CCI}=3V\sim 3.6V$	2				V
			$V_{CCI}=4.5V\sim 5.5V$	V_{CCA} $\times 0.7$				V
Low-Level Input Voltage	Data Inputs (Note 1)	V_{IL}	$V_{CCI}=1.65V\sim 1.95V$			V_{CCI} $\times 0.35$	V	
			$V_{CCI}=2.3V\sim 2.7V$			0.7	V	
			$V_{CCI}=3V\sim 3.6V$			0.8	V	
			$V_{CCI}=4.5V\sim 5.5V$			V_{CCI} $\times 0.3$	V	
	DIR (Referenced to V_{CCA}) (Note 2)		$V_{CCI}=1.65V\sim 1.95V$			V_{CCA} $\times 0.35$		V
			$V_{CCI}=2.3V\sim 2.7V$			0.7		V
			$V_{CCI}=3V\sim 3.6V$			0.8		V
			$V_{CCI}=4.5V\sim 5.5V$			V_{CCA} $\times 0.3$		V
Input Voltage		V_{IN}		0		5.5	V	
Output Voltage		V_{OUT}		0		V_{CCO}	V	
Input Transition Rise or Fall Rate	Data Inputs	$\Delta t/\Delta v$	$V_{CCI}=1.65V\sim 1.95V$			20	ns/V	
			$V_{CCI}=2.3V\sim 2.7V$			20	ns/V	
			$V_{CCI}=3V\sim 3.6V$			10	ns/V	
			$V_{CCI}=4.5V\sim 5.5V$			5	ns/V	
	Control Input		$V_{CCI}=1.65V\sim 1.95V$			5	ns/V	
Operating Temperature		T_A		-40		+125	°C	

Notes: 1. For V_{CCI} values not specified in the data sheet, $V_{IH} \text{ min} = V_{CCI} \times 0.7V$, $V_{IL} \text{ max} = V_{CCI} \times 0.3V$.

2. For V_{CCI} values not specified in the data sheet, $V_{IH} \text{ min} = V_{CCA} \times 0.7V$, $V_{IL} \text{ max} = V_{CCA} \times 0.3V$.

■ ELECTRICAL CHARACTERISTICS (T_A=25°C , unless otherwise specified)

PARAMETER		SYMBOL	TEST CONDITIONS	MIN	TYP	MAX	UNIT
Output High Voltage		V _{OH}	V _I =V _{IH}	V _{CCA} =1.65V~4.5V, V _{CCB} =1.65V~4.5V, I _{OH} =-100μA	V _{CCO} -0.1		V
				V _{CCA} =1.65V, V _{CCB} =1.65V, I _{OH} =-4mA	1.2		V
				V _{CCA} =2.3V, V _{CCB} =2.3V, I _{OH} =-8mA	1.9		V
				V _{CCA} =3V, V _{CCB} =3V, I _{OH} =-24mA	2.4		V
				V _{CCA} =4.5V, V _{CCB} =4.5V, I _{OH} =-32mA	3.8		V
Output Low Voltage		V _{OL}	V _I =V _{IL}	V _{CCA} =1.65V~4.5V, V _{CCB} =1.65V~4.5V, I _{OL} =100μA		0.1	V
				V _{CCA} =1.65V, V _{CCB} =1.65V, I _{OL} =4mA		0.45	V
				V _{CCA} =2.3V, V _{CCB} =2.3V, I _{OL} =8mA		0.3	V
				V _{CCA} =3V, V _{CCB} =3V, I _{OL} =24mA		0.55	V
				V _{CCA} =4.5V, V _{CCB} =4.5V, I _{OL} =32mA		0.55	V
Input Leakage Current	DIR	I _{I(LEAK)}	V _{IN} =V _{CCA} or GND, V _{CCA} =1.65V~5.5V, V _{CCB} =1.65V~5.5V			±1	μA
Power OFF Leakage Current	A Port	I _{OFF}	V _{IN} or V _{OUT} =0~5.5V, V _{CCA} =0V, V _{CCB} =0V~5.5V			±1	μA
	B Port		V _{IN} or V _{OUT} =0~5.5V, V _{CCA} =0V~5.5V, V _{CCB} =0V			±1	μA
Output OFF-State Current	A or B Port	I _{OZ}	V _{OUT} =V _{CCO} or GND, V _{IN} =V _{CCI} or GND, V _{CCA} =5.5V, V _{CCB} =0V			±1	μA
Supply A Current		I _{CCA}	V _{IN} =V _{CCI} or GND, I _{OUT} =0A	V _{CCA} =1.65V~5.5V, V _{CCB} =1.65V~5.5V		3	μA
				V _{CCA} =5V, V _{CCB} =0V		2	μA
				V _{CCA} =0V, V _{CCB} =5V		-2	μA
Supply B Current		I _{CCB}	V _{IN} =V _{CCI} or GND, I _{OUT} =0A	V _{CCA} =1.65V~5.5V, V _{CCB} =1.65V~5.5V		3	μA
				V _{CCA} =5V, V _{CCB} =0V		-2	μA
				V _{CCA} =0V, V _{CCB} =5V		2	μA
Supply A Current & Supply B Current		I _{CCA} +I _{CCB}				4	μA

■ ELECTRICAL CHARACTERISTICS (Cont.)

PARAMETER		SYMBOL	TEST CONDITIONS	MIN	TYP	MAX	UNIT
Supply A Current	A Port	ΔI_{CCA}	One A Port at $V_{CCA}-0.6V$, DIR at V_{CCA} , B Port=OPEN			50	μA
Supply A Current	DIR		DIR at $V_{CCA}-0.6V$, B Port=OPEN, A Port at V_{CCA} or GND				
Supply B Current	B Port	ΔI_{CCB}	One B Port at $V_{CCB}-0.6V$ DIR at GND, A Port=OPEN				
Input Capacitance	Control Inputs	C_{IN}	$V_I=V_{CCA}$ or GND	$V_{CCA}=3.3V$, $V_{CCB}=3.3V$	2.5		pF
Output Capacitance	A or B Port	C_{IO}	$V_O=V_{CCA/B}$ or GND				

Notes: 1. V_{CCI} is the voltage associated with the input port supply V_{CCA} or V_{CCB} .

2. V_{CCO} is the voltage associated with the output port supply V_{CCA} or V_{CCB} .

■ SWITCHING CHARACTERISTICS ($T_A=25^\circ\text{C}$, unless otherwise specified)

PARAMETER	SYMBOL	TEST CONDITIONS	MIN	TYP	MAX	UNIT	
Propagation Delay From Input (A) to Output (B)	t_{PLH}	$V_{CCA}=1.8\text{V}\pm 0.15\text{V}$	$V_{CCB}=1.8\text{V}\pm 0.15\text{V}$	3.0		17.7	ns
			$V_{CCB}=2.5\text{V}\pm 0.2\text{V}$	2.2		10.3	ns
			$V_{CCB}=3.3\text{V}\pm 0.3\text{V}$	1.7		8.3	ns
			$V_{CCB}=5\text{V}\pm 0.5\text{V}$	1.4		7.2	ns
		$V_{CCA}=2.5\text{V}\pm 0.2\text{V}$	$V_{CCB}=1.8\text{V}\pm 0.15\text{V}$	2.3		16	ns
			$V_{CCB}=2.5\text{V}\pm 0.2\text{V}$	1.5		8.5	ns
			$V_{CCB}=3.3\text{V}\pm 0.3\text{V}$	1.3		6.4	ns
			$V_{CCB}=5\text{V}\pm 0.5\text{V}$	1.1		5.1	ns
		$V_{CCA}=3.3\text{V}\pm 0.3\text{V}$	$V_{CCB}=1.8\text{V}\pm 0.15\text{V}$	2.1		15.5	ns
			$V_{CCB}=2.5\text{V}\pm 0.2\text{V}$	1.4		8.0	ns
			$V_{CCB}=3.3\text{V}\pm 0.3\text{V}$	0.7		5.6	ns
			$V_{CCB}=5\text{V}\pm 0.5\text{V}$	0.4		4.4	ns
		$V_{CCA}=5\text{V}\pm 0.5\text{V}$	$V_{CCB}=1.8\text{V}\pm 0.15\text{V}$	1.9		15.1	ns
			$V_{CCB}=2.5\text{V}\pm 0.2\text{V}$	1.0		7.5	ns
			$V_{CCB}=3.3\text{V}\pm 0.3\text{V}$	0.6		5.4	ns
			$V_{CCB}=5\text{V}\pm 0.5\text{V}$	0.5		3.9	ns
Propagation Delay From Input (B) to Output (A)	t_{PLH}	$V_{CCA}=1.8\text{V}\pm 0.15\text{V}$	$V_{CCB}=1.8\text{V}\pm 0.15\text{V}$	3.0		17.7	ns
			$V_{CCB}=2.5\text{V}\pm 0.2\text{V}$	2.3		16	ns
			$V_{CCB}=3.3\text{V}\pm 0.3\text{V}$	2.1		15.5	ns
			$V_{CCB}=5\text{V}\pm 0.5\text{V}$	1.9		15.1	ns
		$V_{CCA}=2.5\text{V}\pm 0.2\text{V}$	$V_{CCB}=1.8\text{V}\pm 0.15\text{V}$	2.2		10.3	ns
			$V_{CCB}=2.5\text{V}\pm 0.2\text{V}$	1.5		8.5	ns
			$V_{CCB}=3.3\text{V}\pm 0.3\text{V}$	1.4		8.0	ns
			$V_{CCB}=5\text{V}\pm 0.5\text{V}$	1.0		7.5	ns
		$V_{CCA}=3.3\text{V}\pm 0.3\text{V}$	$V_{CCB}=1.8\text{V}\pm 0.15\text{V}$	1.7		8.3	ns
			$V_{CCB}=2.5\text{V}\pm 0.2\text{V}$	1.3		6.4	ns
			$V_{CCB}=3.3\text{V}\pm 0.3\text{V}$	0.7		5.8	ns
			$V_{CCB}=5\text{V}\pm 0.5\text{V}$	0.6		5.4	ns
		$V_{CCA}=5\text{V}\pm 0.5\text{V}$	$V_{CCB}=1.8\text{V}\pm 0.15\text{V}$	1.4		7.2	ns
			$V_{CCB}=2.5\text{V}\pm 0.2\text{V}$	1.0		5.1	ns
			$V_{CCB}=3.3\text{V}\pm 0.3\text{V}$	0.7		4.4	ns
			$V_{CCB}=5\text{V}\pm 0.5\text{V}$	0.5		3.9	ns
Propagation Delay From Input (A) to Output (B)	t_{PHL}	$V_{CCA}=1.8\text{V}\pm 0.15\text{V}$	$V_{CCB}=1.8\text{V}\pm 0.15\text{V}$	2.8		14.3	ns
			$V_{CCB}=2.5\text{V}\pm 0.2\text{V}$	2.2		8.5	ns
			$V_{CCB}=3.3\text{V}\pm 0.3\text{V}$	1.8		7.1	ns
			$V_{CCB}=5\text{V}\pm 0.5\text{V}$	1.7		7.0	ns
		$V_{CCA}=2.5\text{V}\pm 0.2\text{V}$	$V_{CCB}=1.8\text{V}\pm 0.15\text{V}$	2.1		12.9	ns
			$V_{CCB}=2.5\text{V}\pm 0.2\text{V}$	1.4		7.5	ns
			$V_{CCB}=3.3\text{V}\pm 0.3\text{V}$	1.3		5.4	ns
			$V_{CCB}=5\text{V}\pm 0.5\text{V}$	0.9		4.6	ns
		$V_{CCA}=3.3\text{V}\pm 0.3\text{V}$	$V_{CCB}=1.8\text{V}\pm 0.15\text{V}$	2.0		12.6	ns
			$V_{CCB}=2.5\text{V}\pm 0.2\text{V}$	1.3		7.0	ns
			$V_{CCB}=3.3\text{V}\pm 0.3\text{V}$	0.8		5.0	ns
			$V_{CCB}=5\text{V}\pm 0.5\text{V}$	0.7		4.0	ns
		$V_{CCA}=5\text{V}\pm 0.5\text{V}$	$V_{CCB}=1.8\text{V}\pm 0.15\text{V}$	1.8		12.2	ns
			$V_{CCB}=2.5\text{V}\pm 0.2\text{V}$	0.9		6.2	ns
			$V_{CCB}=3.3\text{V}\pm 0.3\text{V}$	0.7		4.5	ns
			$V_{CCB}=5\text{V}\pm 0.5\text{V}$	0.5		3.5	ns

■ SWITCHING CHARACTERISTICS (T_A=25°C , unless otherwise specified)

PARAMETER	SYMBOL	TEST CONDITIONS	MIN	TYP	MAX	UNIT	
Propagation Delay From Input (B) to Output (A)	t _{PHL}	V _{CCA} =1.8V±0.15V	V _{CCB} =1.8V±0.15V	2.8		14.3	ns
			V _{CCB} =2.5V±0.2V	2.1		12.9	ns
			V _{CCB} =3.3V±0.3V	2.0		12.6	ns
			V _{CCB} =5V±0.5V	1.8		12.2	ns
		V _{CCA} =2.5V±0.2V	V _{CCB} =1.8V±0.15V	2.2		8.5	ns
			V _{CCB} =2.5V±0.2V	1.4		7.5	ns
			V _{CCB} =3.3V±0.3V	1.3		7.0	ns
			V _{CCB} =5V±0.5V	0.9		6.2	ns
		V _{CCA} =3.3V±0.3V	V _{CCB} =1.8V±0.15V	1.8		7.1	ns
			V _{CCB} =2.5V±0.2V	1.3		5.4	ns
			V _{CCB} =3.3V±0.3V	0.8		5.0	ns
			V _{CCB} =5V±0.5V	0.7		4.5	ns
		V _{CCA} =5V±0.5V	V _{CCB} =1.8V±0.15V	1.7		7.0	ns
			V _{CCB} =2.5V±0.2V	0.9		4.6	ns
			V _{CCB} =3.3V±0.3V	0.7		4.0	ns
			V _{CCB} =5V±0.5V	0.5		3.5	ns
Propagation Delay From Input (DIR) to Output (A)	t _{PHZ}	V _{CCA} =1.8V±0.15V	V _{CCB} =1.8V±0.15V	10.6		30.9	ns
			V _{CCB} =2.5V±0.2V	10.3		30.5	ns
			V _{CCB} =3.3V±0.3V	10.5		30.5	ns
			V _{CCB} =5V±0.5V	10.7		29.3	ns
		V _{CCA} =2.5V±0.2V	V _{CCB} =1.8V±0.15V	6.6		17.1	ns
			V _{CCB} =2.5V±0.2V	7.1		16.8	ns
			V _{CCB} =3.3V±0.3V	6.8		16.8	ns
			V _{CCB} =5V±0.5V	5.2		16.5	ns
		V _{CCA} =3.3V±0.3V	V _{CCB} =1.8V±0.15V	5.0		10.9	ns
			V _{CCB} =2.5V±0.2V	5.1		10.8	ns
			V _{CCB} =3.3V±0.3V	5.0		10.8	ns
			V _{CCB} =5V±0.5V	5.0		10.4	ns
		V _{CCA} =5V±0.5V	V _{CCB} =1.8V±0.15V	2.9		8.2	ns
			V _{CCB} =2.5V±0.2V	2.9		7.9	ns
			V _{CCB} =3.3V±0.3V	2.8		7.9	ns
			V _{CCB} =5V±0.5V	2.2		7.8	ns
Propagation Delay From Input (DIR) to Output (B)	t _{PHZ}	V _{CCA} =1.8V±0.15V	V _{CCB} =1.8V±0.15V	10		27.9	ns
			V _{CCB} =2.5V±0.2V	8.4		14.9	ns
			V _{CCB} =3.3V±0.3V	6.5		11.3	ns
			V _{CCB} =5V±0.5V	4.1		8.6	ns
		V _{CCA} =2.5V±0.2V	V _{CCB} =1.8V±0.15V	10.7		27.9	ns
			V _{CCB} =2.5V±0.2V	8.1		13.9	ns
			V _{CCB} =3.3V±0.3V	5.8		10.5	ns
			V _{CCB} =5V±0.5V	3.5		7.6	ns
		V _{CCA} =3.3V±0.3V	V _{CCB} =1.8V±0.15V	11.2		27.3	ns
			V _{CCB} =2.5V±0.2V	8.0		13.7	ns
			V _{CCB} =3.3V±0.3V	5.8		10.4	ns
			V _{CCB} =5V±0.5V	2.9		7.4	ns
		V _{CCA} =5V±0.5V	V _{CCB} =1.8V±0.15V	11.2		26.1	ns
			V _{CCB} =2.5V±0.2V	7.2		13.9	ns
			V _{CCB} =3.3V±0.3V	5.8		10.1	ns
			V _{CCB} =5V±0.5V	1.3		7.3	ns

■ SWITCHING CHARACTERISTICS (Cont.)

PARAMETER	SYMBOL	TEST CONDITIONS	MIN	TYP	MAX	UNIT			
Propagation Delay From Input (DIR) to Output (A)	t _{PLZ}	V _{CCA} =1.8V±0.15V	V _{CCB} =1.8V±0.15V	7.3		19.7	ns		
			V _{CCB} =2.5V±0.2V	7.5		19.6	ns		
			V _{CCB} =3.3V±0.3V	7.5		19.5	ns		
			V _{CCB} =5V±0.5V	7.0		19.4	ns		
		V _{CCA} =2.5V±0.2V	V _{CCB} =1.8V±0.15V	5.3		12.6	ns		
			V _{CCB} =2.5V±0.2V	5.2		12.5	ns		
			V _{CCB} =3.3V±0.3V	4.9		12.3	ns		
		V _{CCA} =3.3V±0.3V	V _{CCB} =5V±0.5V	4.8		12.3	ns		
			V _{CCB} =1.8V±0.15V	3.4		8.4	ns		
			V _{CCB} =2.5V±0.2V	3.7		8.4	ns		
		V _{CCA} =5V±0.5V	V _{CCB} =3.3V±0.3V	3.9		8.1	ns		
			V _{CCB} =5V±0.5V	3.3		7.8	ns		
			V _{CCB} =1.8V±0.15V	1.4		6.9	ns		
			V _{CCB} =2.5V±0.2V	1.3		6.7	ns		
		Propagation Delay From Input (DIR) to Output (B)	t _{PLZ}	V _{CCA} =1.8V±0.15V	V _{CCB} =1.8V±0.15V	6.5		19.5	ns
					V _{CCB} =2.5V±0.2V	7.2		12.6	ns
V _{CCB} =3.3V±0.3V	4.3					9.7	ns		
V _{CCB} =5V±0.5V	2.1					7.1	ns		
V _{CCA} =2.5V±0.2V	V _{CCB} =1.8V±0.15V			7.8		18.9	ns		
	V _{CCB} =2.5V±0.2V			6.2		11.2	ns		
	V _{CCB} =3.3V±0.3V			3.6		8.9	ns		
V _{CCA} =3.3V±0.3V	V _{CCB} =5V±0.5V			1.4		6.2	ns		
	V _{CCB} =1.8V±0.15V			9.4		17.7	ns		
	V _{CCB} =2.5V±0.2V			5.6		11.3	ns		
V _{CCA} =5V±0.5V	V _{CCB} =3.3V±0.3V			4.3		8.3	ns		
	V _{CCB} =5V±0.5V			1.0		5.6	ns		
	V _{CCB} =1.8V±0.15V			8.4		16.9	ns		
	V _{CCB} =2.5V±0.2V			5.0		11	ns		
Propagation Delay From Input (DIR) to Output (A)	t _{PZH}			V _{CCA} =1.8V±0.15V	V _{CCB} =1.8V±0.15V			37.2	ns
					V _{CCB} =2.5V±0.2V			28.6	ns
		V _{CCB} =3.3V±0.3V				25.2	ns		
		V _{CCB} =5V±0.5V				22.2	ns		
		V _{CCA} =2.5V±0.2V	V _{CCB} =1.8V±0.15V			29.2	ns		
			V _{CCB} =2.5V±0.2V			19.7	ns		
			V _{CCB} =3.3V±0.3V			16.9	ns		
		V _{CCA} =3.3V±0.3V	V _{CCB} =5V±0.5V			13.7	ns		
			V _{CCB} =1.8V±0.15V			26	ns		
			V _{CCB} =2.5V±0.2V			17.7	ns		
		V _{CCA} =5V±0.5V	V _{CCB} =3.3V±0.3V			14.1	ns		
			V _{CCB} =5V±0.5V			11	ns		
			V _{CCB} =1.8V±0.15V			24.1	ns		
			V _{CCB} =2.5V±0.2V			16.1	ns		
		V _{CCA} =5V±0.5V	V _{CCB} =3.3V±0.3V			12.1	ns		
			V _{CCB} =5V±0.5V			9.5	ns		

■ SWITCHING CHARACTERISTICS (Cont.)

PARAMETER	SYMBOL	TEST CONDITIONS	MIN	TYP	MAX	UNIT
Propagation Delay From Input (DIR) to Output (B)	t _{PZH}	V _{CCA} =1.8V±0.15V	V _{CCB} =1.8V±0.15V		37.4	ns
			V _{CCB} =2.5V±0.2V		29.9	ns
			V _{CCB} =3.3V±0.3V		27.8	ns
			V _{CCB} =5V±0.5V		26.6	ns
		V _{CCA} =2.5V±0.2V	V _{CCB} =1.8V±0.15V		28.6	ns
			V _{CCB} =2.5V±0.2V		21	ns
			V _{CCB} =3.3V±0.3V		18.7	ns
			V _{CCB} =5V±0.5V		17.4	ns
		V _{CCA} =3.3V±0.3V	V _{CCB} =1.8V±0.15V		23.9	ns
			V _{CCB} =2.5V±0.2V		16.4	ns
			V _{CCB} =3.3V±0.3V		13.9	ns
			V _{CCB} =5V±0.5V		12.2	ns
		V _{CCA} =5V±0.5V	V _{CCB} =1.8V±0.15V		22	ns
			V _{CCB} =2.5V±0.2V		14.2	ns
			V _{CCB} =3.3V±0.3V		12.1	ns
			V _{CCB} =5V±0.5V		10.5	ns
Propagation Delay From Input (DIR) to Output (A)	t _{PZL}	V _{CCA} =1.8V±0.15V	V _{CCB} =1.8V±0.15V		42.2	ns
			V _{CCB} =2.5V±0.2V		27.8	ns
			V _{CCB} =3.3V±0.3V		23.9	ns
			V _{CCB} =5V±0.5V		20.8	ns
		V _{CCA} =2.5V±0.2V	V _{CCB} =1.8V±0.15V		36.4	ns
			V _{CCB} =2.5V±0.2V		21.4	ns
			V _{CCB} =3.3V±0.3V		17.5	ns
			V _{CCB} =5V±0.5V		13.8	ns
		V _{CCA} =3.3V±0.3V	V _{CCB} =1.8V±0.15V		34.4	ns
			V _{CCB} =2.5V±0.2V		19.1	ns
			V _{CCB} =3.3V±0.3V		15.4	ns
			V _{CCB} =5V±0.5V		11.9	ns
		V _{CCA} =5V±0.5V	V _{CCB} =1.8V±0.15V		33.1	ns
			V _{CCB} =2.5V±0.2V		18.5	ns
			V _{CCB} =3.3V±0.3V		14.1	ns
			V _{CCB} =5V±0.5V		10.8	ns
Propagation Delay From Input (DIR) to Output (B)	t _{PZL}	V _{CCA} =1.8V±0.15V	V _{CCB} =1.8V±0.15V		45.2	ns
			V _{CCB} =2.5V±0.2V		39	ns
			V _{CCB} =3.3V±0.3V		37.6	ns
			V _{CCB} =5V±0.5V		36.3	ns
		V _{CCA} =2.5V±0.2V	V _{CCB} =1.8V±0.15V		30	ns
			V _{CCB} =2.5V±0.2V		24.3	ns
			V _{CCB} =3.3V±0.3V		22.2	ns
			V _{CCB} =5V±0.5V		21.1	ns
		V _{CCA} =3.3V±0.3V	V _{CCB} =1.8V±0.15V		23.5	ns
			V _{CCB} =2.5V±0.2V		17.8	ns
			V _{CCB} =3.3V±0.3V		15.8	ns
			V _{CCB} =5V±0.5V		14.4	ns
		V _{CCA} =5V±0.5V	V _{CCB} =1.8V±0.15V		20.4	ns
			V _{CCB} =2.5V±0.2V		14.1	ns
			V _{CCB} =3.3V±0.3V		12.4	ns
			V _{CCB} =5V±0.5V		11.3	ns

■ OPERATING CHARACTERISTICS (T_A=25°C, unless otherwise specified)

PARAMETER		SYMBOL	TEST CONDITIONS	MIN	TYP	MAX	UNIT
Power Dissipation Capacitance	A Port Input B Port Output	C _{PD A}	V _{CCB} =1.8V		3		pF
			V _{CCB} =2.5V		4		pF
			V _{CCB} =3.3V		4		pF
			V _{CCB} =5V		4		pF
	B Port Input A Port Output		V _{CCB} =1.8V		18		pF
			V _{CCB} =2.5V		19		pF
			V _{CCB} =3.3V		20		pF
			V _{CCB} =5V		21		pF
	A Port Input B Port Output	C _{PD B}	V _{CCB} =1.8V		18		pF
			V _{CCB} =2.5V		19		pF
			V _{CCB} =3.3V		20		pF
			V _{CCB} =5V		21		pF
	B Port Input A Port Output		V _{CCB} =1.8V		3		pF
			V _{CCB} =2.5V		4		pF
			V _{CCB} =3.3V		4		pF
			V _{CCB} =5V		4		pF

■ TEST CIRCUIT AND WAVEFORMS

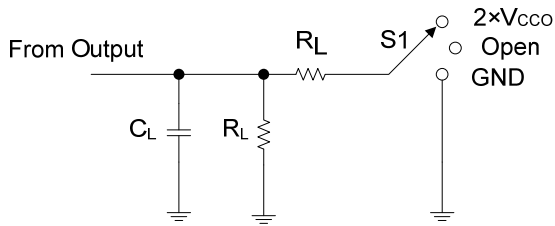

TEST	S1
t_{PD}	Open
t_{PLZ}/t_{PZL}	$2 \times V_{CCO}$
t_{PHZ}/t_{PZH}	GND

LOAD CIRCUIT

V_{CC}	C_L	R_L	V_{TP}
$1.8V \pm 0.15V$	15pF	2k Ω	0.15V
$2.5V \pm 0.2V$	15pF	2k Ω	0.15V
$3.3V \pm 0.3V$	15pF	2k Ω	0.3V
$5V \pm 0.5V$	15pF	2k Ω	0.3V

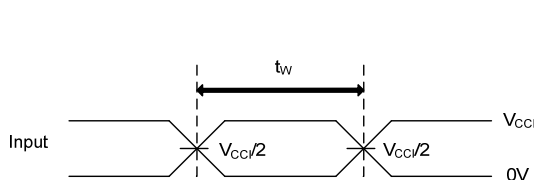

PULSE DURATION

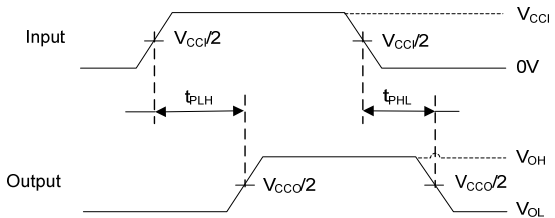

PROPAGATION DELAY TIMES

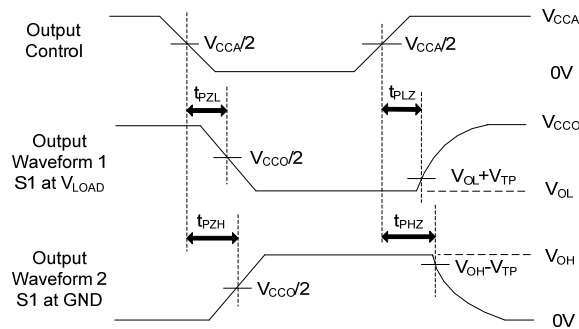

ENABLE AND DISABLE TIMES

Notes: 1. C_L includes probe and jig capacitance.

2. All input pulses are supplied by generators having the following characteristics: PRR \leq 10MHz, $Z_O = 50\Omega$, $dv/dt \geq 1V/ns$.

■ DETAILED DESCRIPTION**Overview**

The **U74LVC2T45** is dual-bit, dual-supply noninverting voltage level translation. Pin Ax and direction control pin are support by V_{CCA} and pin Bx are support by V_{CCB} . The A port is able to accept I/O voltages ranging from 1.65V to 5.5V, while the B port can accept I/O voltages from 1.65V to 5.5V. The high on DIR allows data transmission from A to B and a low on DIR allows data transmission from B to A.

■ FEATURES DESCRIPTION**Feature Description**

Fully Configurable Dual-Rail Design Allows Each Port to Operate Over the Full 1.65V to 5.5V

Power-Supply Range

Both V_{CCA} and V_{CCB} can be supplied at any voltage between 1.65V and 5.5 V making the device suitable for translating between any of the voltage nodes (1.8V, 2.5V, 3.3V and 5V).

Support High-Speed Translation

U74LVC2T45 can support high data rate application. The translated signal data rate can be up to 420 Mbps when signal is translated from 3.3V to 5V.

I_{OFF} Supports Partial-Power-Down Mode Operation

I_{OFF} will prevent backflow current by disabling I/O output circuits when device is in partial-power-down mode.

Application Information

The **U74LVC2T45** device can be used in level-translation applications for interfacing devices or systems operating at different interface voltages with one another. The maximum data rate can be up to 420 Mbps when device translate signal from 3.3V to 5V.

■ TYPICAL APPLICATION CIRCUIT

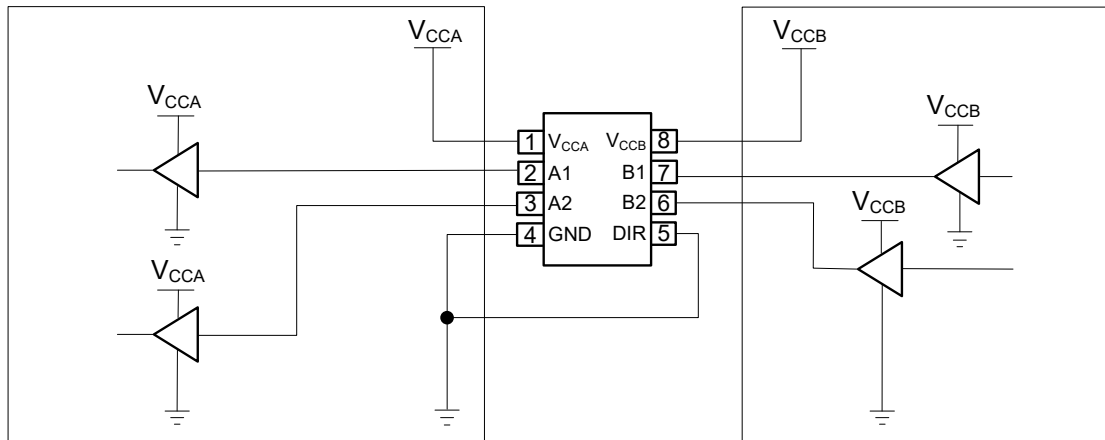

UTC assumes no responsibility for equipment failures that result from using products at values that exceed, even momentarily, rated values (such as maximum ratings, operating condition ranges, or other parameters) listed in products specifications of any and all UTC products described or contained herein. UTC products are not designed for use in life support appliances, devices or systems where malfunction of these products can be reasonably expected to result in personal injury. Reproduction in whole or in part is prohibited without the prior written consent of the copyright owner. UTC reserves the right to make changes to information published in this document, including without limitation specifications and product descriptions, at any time and without notice. This document supersedes and replaces all information supplied prior to the publication hereof.