



U74LVC1T45

CMOS IC

SINGLE-BIT DUAL-SUPPLY BUS TRANSCEIVER WITH CONFIGURABLE VOLTAGE TRANSLATION

DESCRIPTION

This single-bit noninverting bus transceiver uses two separate configurable power supply rails. The A port is designed to track V_{CCA} . V_{CCA} accepts any supply voltage from 1.65V to 5.5V. The B port is designed to track V_{CCB} . V_{CCB} accepts any supply voltage from 1.65V to 5.5V. This allows for universal low-voltage bidirectional translation between any of the 1.8V, 2.5V, 3.3V and 5V voltage nodes.

The **U74LVC1T45** is designed for asynchronous communication between two data buses. The logic levels of the direction-control (DIR) input activate either the B port outputs or the A port outputs. The device transmits data from the A bus to the B bus when the B port outputs are activated and from the B bus to the A bus when the A port outputs are activated. The input circuitry is always active on both A and B ports and must have a logic HIGH or LOW level applied to prevent excess I_{CC} and I_{CCZ} .

FEATURES

- * Fully Configurable Dual-Rail Design Allows Each Port to Operate Over the Full 1.65V to 5.5V Power-Supply Range
- * V_{CC} Isolation Feature – If Either V_{CC} Input Is at GND, Both Ports Are in the High-Impedance State
- * DIR Input Circuit Referenced to V_{CCA}
- * $\pm 24mA$ Output Drive at 3.3V
- * I_{OFF} Supports Partial-Power-Down Mode Operation

ORDERING INFORMATION

Ordering Number		Package	Packing
Lead Free	Halogen Free		
U74LVC1T45L-AG6-R	U74LVC1T45G-AG6-R	SOT-26	Tape Reel
U74LVC1T45L-AL6-R	U74LVC1T45G-AL6-R	SOT-363	Tape Reel

<p>U74LVC1T45G-AG6-R</p> <p>(1) Packing Type (2) Package Type (3) Green Package</p>	<p>(1) R: Tape Reel (2) AG6: SOT-26, AL6: SOT-363 (3) G: Halogen Free and Lead Free, L: Lead Free</p>
---	---

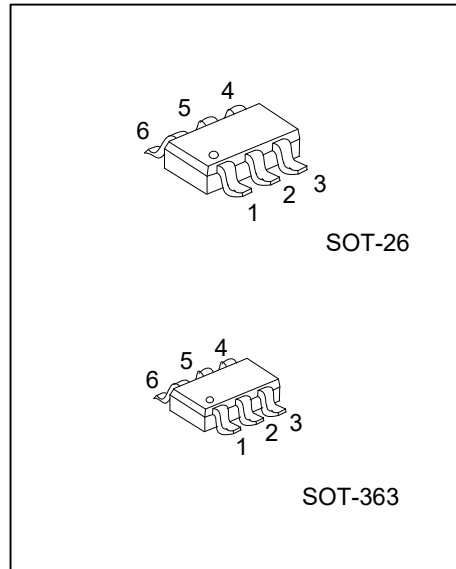

MARKING

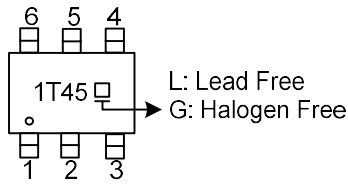

PIN CONFIGURATION

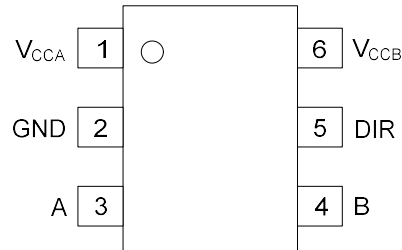

PIN DESCRIPTION

PIN NO.	PIN NAME	I/O	DESCRIPTION
1	V _{CCA}	P	SYSTEM-1 supply voltage (1.65V to 5.5V)
2	GND	G	Ground
3	A	I/O	Output level depends on V _{CCA} voltage
4	B	I/O	Input threshold value depends on V _{CCB} voltage
5	DIR	I	GND (Low level) determines B-port to A-port direction
6	V _{CCB}	P	SYSTEM-2 supply voltage (1.65V to 5.5V)

Note: P=Power, G=Ground, I/O=Input and output, I=Input

FUNCTION TABLE

INPUTS DIR	OPERATION
L	B data to A bus
H	A data to B bus

LOGIC DIAGRAM (POSITIVE LOGIC)

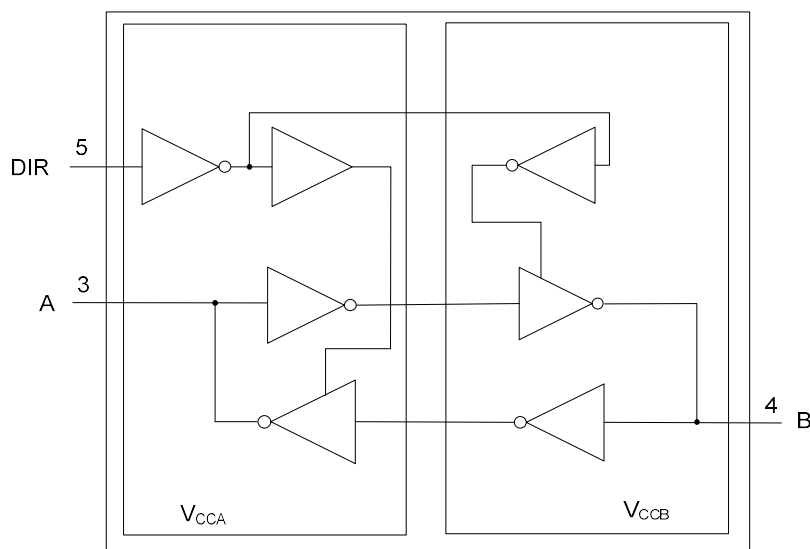

■ ABSOLUTE MAXIMUM RATING

PARAMETER	SYMBOL	TEST CONDITIONS	RATINGS	UNIT
Supply Voltage	V_{CCA}		-0.5 ~ 6.5	V
Supply Voltage	V_{CCB}		-0.5 ~ 6.5	V
Input Voltage (Note 2)	V_{IN}	A Port	-0.5 ~ 6.5	V
		B Port	-0.5 ~ 6.5	V
		Control Input	-0.5 ~ 6.5	V
Voltage applied to any output in the high-impedance or power off state (Note 2)	V_{OUT}	A Port	-0.5 ~ 6.5	V
		B Port	-0.5 ~ 6.5	V
Voltage applied to any output in the high or low state (Note 2, 3)	V_{OUT}	A Port	-0.5 ~ $V_{CCA}+0.5$	V
		B Port	-0.5 ~ $V_{CCB}+0.5$	V
Continuous Output Current	I_{OUT}		±50	mA
Continuous current through V_{CCA} , V_{CCB} or GND			±100	mA
Input Clamp Current	I_{IK}	$V_{IN}<0V$	-50	mA
Output Clamp Current	I_{OK}	$V_{OUT}<0V$	-50	mA
Storage Temperature Range	T_{STG}		-65 ~ +150	°C

- Notes: 1. Absolute maximum ratings are those values beyond which the device could be permanently damaged. Absolute maximum ratings are stress ratings only and functional device operation is not implied.
2. The input negative-voltage and output voltage ratings may be exceeded if the input and output current ratings are observed.
3. The value of V_{CC} is provided in the recommended operating conditions table.

■ RECOMMENDED OPERATING CONDITIONS

PARAMETER	SYMBOL	TEST CONDITIONS	MIN	TYP	MAX	UNIT
Supply Voltage	V_{CCA}		1.65		5.5	V
Supply Voltage	V_{CCB}		1.65		5.5	V
Input Voltage	V_{IN}		0		5.5	V
Output Voltage	V_{OUT}		0		V_{CCO}	V
Input Transition Rise or Fall Rate	Data Inputs	$\Delta t/\Delta v$	$V_{CCI}=1.65V\sim 1.95V$		20	ns/V
			$V_{CCI}=2.3V\sim 2.7V$		20	ns/V
			$V_{CCI}=3V\sim 3.6V$		10	ns/V
			$V_{CCI}=4.5V\sim 5.5V$		5	ns/V
			$V_{CCI}=1.65V\sim 1.95V$		5	ns/V
Operating Temperature	T_A		-40		+125	°C

■ ELECTRICAL CHARACTERISTICS (Unless otherwise specified)

PARAMETER		SYMBOL	TEST CONDITIONS	T _A =25°C			T _A =-40°C~+125°C			UNIT
				MIN	TYP	MAX	MIN	TYP	MAX	
High-Level Input Voltage	Data Inputs (Note 1)	V _{IH}	V _{CCI} =1.65V~1.95V	V _{CCI} ×0.65			V _{CCI} ×0.65			V
			V _{CCI} =2.3V~2.7V	1.7			1.7			V
			V _{CCI} =3V~3.6V	2			2			V
			V _{CCI} =4.5V~5.5V	V _{CCI} ×0.7			V _{CCI} ×0.7			V
	DIR (Reference d to V _{CCA}) (Note 2)		V _{CCI} =1.65V~1.95V	V _{CCA} ×0.65			V _{CCA} ×0.65			V
			V _{CCI} =2.3V~2.7V	1.7			1.7			V
			V _{CCI} =3V~3.6V	2			2			V
			V _{CCI} =4.5V~5.5V	V _{CCA} ×0.7			V _{CCA} ×0.7			V
Low-Level Input Voltage	Data Inputs (Note 1)	V _{IL}	V _{CCI} =1.65V~1.95V			V _{CCI} ×0.35			V _{CCI} ×0.35	V
			V _{CCI} =2.3V~2.7V			0.7			0.7	V
			V _{CCI} =3V~3.6V			0.8			0.8	V
			V _{CCI} =4.5V~5.5V			V _{CCI} ×0.3			V _{CCI} ×0.3	V
	DIR (Reference d to V _{CCA}) (Note 2)		V _{CCI} =1.65V~1.95V			V _{CCA} ×0.35			V _{CCA} ×0.35	V
			V _{CCI} =2.3V~2.7V			0.7			0.7	V
			V _{CCI} =3V~3.6V			0.8			0.8	V
			V _{CCI} =4.5V~5.5V			V _{CCA} ×0.3			V _{CCA} ×0.3	V

Notes: 1. For V_{CCI} values not specified in the data sheet, V_{IH} min=V_{CCI}×0.7V, V_{IL} max=V_{CCI}×0.3V.

2. For V_{CCI} values not specified in the data sheet, V_{IH} min=V_{CCA}×0.7V, V_{IL} max=V_{CCA}×0.3V.

■ ELECTRICAL CHARACTERISTICS (Cont.)

PARAMETER	SYMBOL	TEST CONDITIONS	T _A =25°C			T _A =-40°C~+125°C			UNIT	
			MIN	TYP	MAX	MIN	TYP	MAX		
Output High Voltage	V _{OH}	V _I =V _{IH}	V _{CCA} =1.65V~4.5V, V _{CCB} =1.65V~4.5V, I _{OH} =-100μA	V _{CCO} -0.1			V _{CCO} -0.1			V
			V _{CCA} =1.65V, V _{CCB} =1.65V, I _{OH} =-4mA	1.2			0.95			V
			V _{CCA} =2.3V, V _{CCB} =2.3V, I _{OH} =-8mA	1.9			1.7			V
			V _{CCA} =3V, V _{CCB} =3V, I _{OH} =-24mA	2.4			2.0			V
			V _{CCA} =4.5V, V _{CCB} =4.5V, I _{OH} =-32mA	3.8			3.4			V
Output Low Voltage	V _{OL}	V _I =V _{IL}	V _{CCA} =1.65V~4.5V, V _{CCB} =1.65V~4.5V, I _{OL} =100μA			0.1			0.1	V
			V _{CCA} =1.65V, V _{CCB} =1.65V, I _{OL} =4mA			0.45			0.7	V
			V _{CCA} =2.3V, V _{CCB} =2.3V, I _{OL} =8mA			0.3			0.45	V
			V _{CCA} =3V, V _{CCB} =3V, I _{OL} =24mA			0.55			0.8	V
			V _{CCA} =4.5V, V _{CCB} =4.5V, I _{OL} =32mA			0.55			0.8	V
Input Leakage Current	DIR	I _{I(LEAK)}	V _{IN} =V _{CCA} or GND, V _{CCA} =1.65V~5.5V, V _{CCB} =1.65V~5.5V			±1			±10	μA
Power OFF Leakage Current	A Port	I _{OFF}	V _{IN} or V _{OUT} =0~5.5V, V _{CCA} =0V, V _{CCB} =0V~5.5V			±1			±10	μA
	B Port		V _{IN} or V _{OUT} =0~5.5V, V _{CCA} =0V~5.5V, V _{CCB} =0V			±1			±10	μA
Output OFF-State Current	A or B Port	I _{OZ}	V _{OUT} =V _{CCO} or GND, V _{IN} =V _{CCI} or GND, V _{CCA} =1.65V~5.5V, V _{CCB} =1.65V~5.5V			±1			±10	μA

Notes: 1. V_{CCI} is the voltage associated with the input port supply V_{CCA} or V_{CCB}.

2. V_{CCO} is the voltage associated with the output port supply V_{CCA} or V_{CCB}.

■ ELECTRICAL CHARACTERISTICS (Cont.)

PARAMETER		SYMBOL	TEST CONDITIONS	T _A =25°C			T _A =-40°C~+125°C			UNIT	
				MIN	TYP	MAX	MIN	TYP	MAX		
Supply A Current		I _{CCA}	V _{CC} A=1.65V~5.5V, V _{CC} B=1.65V~5.5V			3			5	μA	
			V _{CC} A=5.5V, V _{CC} B=0V			2			3	μA	
			V _{CC} A=0V, V _{CC} B=5.5V			-2			-3	μA	
Supply B Current		I _{CCB}	V _{IN} =V _{CCI} or GND, I _{OUT} =0A V _{CC} A=1.65V~5.5V, V _{CC} B=1.65V~5.5V			3			5	μA	
			V _{CC} A=5.5V, V _{CC} B=0V			-2			-3	μA	
			V _{CC} A=0V, V _{CC} B=5.5V			2			3	μA	
Supply A Current & Supply B Current		I _{CCA} +I _{CCB}	V _{CC} A=1.65V~5.5V, V _{CC} B=1.65V~5.5V			4			6	μA	
Supply A Current	A Port	ΔI _{CCA}	A Port at V _{CC} A-0.6 V, DIR at V _{CC} A, B Port=OP EN			50			75	μA	
Supply A Current	DIR		DIR at V _{CC} A-0.6 V, B Port=OP EN, A Port at V _{CC} A or GND	V _{CC} A=3V~5.5V, V _{CC} B=3V~5.5V			50			75	μA
Supply B Current	B Port		B Port at V _{CC} B-0.6 V DIR at GND, A Port=OP EN				50			75	μA

■ **SWITCHING CHARACTERISTICS** (Unless otherwise specified)

PARAMETER	SYMBOL	TEST CONDITIONS	T _A =25°C			T _A =-40°C~+125°C			UNIT			
			MIN	TYP	MAX	MIN	TYP	MAX				
Propagation Delay From Input (A) to Output (B)	t _{PLH}	V _{CCA} =1.8V ±0.15V	V _{CCB} =1.8V±0.15V	1.5		17.7	1.0		19.5	ns		
			V _{CCB} =2.5V±0.2V	1.5		10.3	1.0		12.1	ns		
			V _{CCB} =3.3V±0.3V	1.5		8.3	1.0		9.4	ns		
			V _{CCB} =5V±0.5V	1.0		7.2	0.5		8.1	ns		
		V _{CCA} =2.5V ±0.2V	V _{CCB} =1.8V±0.15V	1.5		16	1.0		17.6	ns		
			V _{CCB} =2.5V±0.2V	1.0		8.5	0.5		9.4	ns		
			V _{CCB} =3.3V±0.3V	1.0		6.4	0.5		7.6	ns		
		V _{CCA} =3.3V ±0.3V	V _{CCB} =1.8V±0.15V	1.5		15.5	1.0		17.1	ns		
			V _{CCB} =2.5V±0.2V	1.0		8.0	0.5		8.8	ns		
			V _{CCB} =3.3V±0.3V	0.5		5.8	0.3		6.2	ns		
		V _{CCA} =5V ±0.5V	V _{CCB} =5V±0.5V	0.3		4.4	0.2		4.9	ns		
			V _{CCB} =1.8V±0.15V	1.5		15.1	1.0		16.7	ns		
			V _{CCB} =2.5V±0.2V	0.5		7.5	0.3		8.3	ns		
			V _{CCB} =3.3V±0.3V	0.3		5.4	0.2		6	ns		
		Propagation Delay From Input (B) to Output (A)	t _{PLH}	V _{CCA} =1.8V ±0.15V	V _{CCB} =1.8V±0.15V	1.5		17.7	1.0		19.5	ns
					V _{CCB} =2.5V±0.2V	1.5		16	1.0		17.6	ns
V _{CCB} =3.3V±0.3V	1.5					15.5	1.0		17.1	ns		
V _{CCB} =5V±0.5V	1.5					15.1	1.0		16.7	ns		
V _{CCA} =2.5V ±0.2V	V _{CCB} =1.8V±0.15V			1.5		10.3	1.0		10.9	ns		
	V _{CCB} =2.5V±0.2V			1.0		8.5	0.5		9.4	ns		
	V _{CCB} =3.3V±0.3V			1.0		8.0	0.5		8.8	ns		
V _{CCA} =3.3V ±0.3V	V _{CCB} =5V±0.5V			0.5		7.5	0.3		8.3	ns		
	V _{CCB} =1.8V±0.15V			1.5		8.3	1.0		8.9	ns		
	V _{CCB} =2.5V±0.2V			1.0		6.4	0.5		6.9	ns		
V _{CCA} =5V ±0.5V	V _{CCB} =3.3V±0.3V			0.5		5.8	0.3		6.6	ns		
	V _{CCB} =5V±0.5V			0.3		4.4	0.2		6	ns		
	V _{CCB} =1.8V±0.15V			1.0		7.2	0.5		7.8	ns		
	V _{CCB} =2.5V±0.2V			0.5		5.1	0.3		5.9	ns		
Propagation Delay From Input (A) to Output (B)	t _{PHL}			V _{CCA} =1.8V ±0.15V	V _{CCB} =3.3V±0.3V	0.3		4.4	0.2		4.9	ns
					V _{CCB} =5V±0.5V	0.2		3.9	0.1		4.3	ns
		V _{CCB} =1.8V±0.15V	1.5			14.3	1.0		15.8	ns		
		V _{CCB} =2.5V±0.2V	1.5			8.5	1.0		9.4	ns		
		V _{CCA} =2.5V ±0.2V	V _{CCB} =3.3V±0.3V	1.5		7.1	1.0		7.9	ns		
			V _{CCB} =5V±0.5V	1.5		7.0	1.0		7.7	ns		
			V _{CCB} =1.8V±0.15V	1.5		12.9	1.0		14.2	ns		
		V _{CCA} =3.3V ±0.3V	V _{CCB} =2.5V±0.2V	1.0		7.5	0.5		8.3	ns		
			V _{CCB} =3.3V±0.3V	1.0		5.4	0.5		6	ns		
			V _{CCB} =5V±0.5V	0.5		4.6	0.3		5.1	ns		
		V _{CCA} =5V ±0.5V	V _{CCB} =1.8V±0.15V	1.5		12.6	1.0		13.9	ns		
			V _{CCB} =2.5V±0.2V	1.0		7.0	0.5		7.7	ns		
			V _{CCB} =3.3V±0.3V	0.5		5.0	0.3		5.5	ns		
			V _{CCB} =5V±0.5V	0.5		4.0	0.3		4.4	ns		
		V _{CCA} =5V ±0.5V	V _{CCB} =1.8V±0.15V	1.5		12.2	1.0		13.5	ns		
			V _{CCB} =2.5V±0.2V	0.5		6.2	0.3		6.9	ns		
V _{CCB} =3.3V±0.3V	0.3			4.5	0.2		5	ns				
		V _{CCB} =5V±0.5V	0.2		3.5	0.1		3.9	ns			

■ SWITCHING CHARACTERISTICS (Cont.)

PARAMETER	SYMBOL	TEST CONDITIONS	T _A =25°C			T _A =-40°C~+125°C			UNIT	
			MIN	TYP	MAX	MIN	TYP	MAX		
Propagation Delay From Input (B) to Output (A)	t _{PHL}	V _{CCA} =1.8V ±0.15V	V _{CCB} =1.8V±0.15V	1.5		14.3	1.0		15.8	ns
			V _{CCB} =2.5V±0.2V	1.5		12.9	1.0		14.2	ns
			V _{CCB} =3.3V±0.3V	1.5		12.6	1.0		13.9	ns
			V _{CCB} =5V±0.5V	1.5		12.2	1.0		13.5	ns
		V _{CCA} =2.5V ±0.2V	V _{CCB} =1.8V±0.15V	1.5		8.5	1.0		9.4	ns
			V _{CCB} =2.5V±0.2V	1.0		7.5	0.5		8.3	ns
			V _{CCB} =3.3V±0.3V	1.0		7.0	0.5		7.7	ns
			V _{CCB} =5V±0.5V	0.5		6.2	0.3		6.9	ns
		V _{CCA} =3.3V ±0.3V	V _{CCB} =1.8V±0.15V	1.5		7.1	1.0		7.9	ns
			V _{CCB} =2.5V±0.2V	1.0		5.4	0.5		6	ns
			V _{CCB} =3.3V±0.3V	0.5		5.0	0.3		5.5	ns
			V _{CCB} =5V±0.5V	0.5		4.5	0.3		5	ns
		V _{CCA} =5V ±0.5V	V _{CCB} =1.8V±0.15V	1.5		7.0	1.0		7.7	ns
			V _{CCB} =2.5V±0.2V	0.5		4.6	0.3		5.1	ns
			V _{CCB} =3.3V±0.3V	0.3		4.0	0.2		4.4	ns
			V _{CCB} =5V±0.5V	0.2		3.5	0.1		3.9	ns
Propagation Delay From Input (DIR) to Output (A)	t _{PHZ}	V _{CCA} =1.8V ±0.15V	V _{CCB} =1.8V±0.15V	1.5		19.4	1.0		21.6	ns
			V _{CCB} =2.5V±0.2V	1.5		18.5	1.0		19.5	ns
			V _{CCB} =3.3V±0.3V	1.5		18.4	1.0		19.2	ns
			V _{CCB} =5V±0.5V	1.5		17.1	1.0		18.9	ns
		V _{CCA} =2.5V ±0.2V	V _{CCB} =1.8V±0.15V	1.5		8.1	1.0		9	ns
			V _{CCB} =2.5V±0.2V	1.5		8.1	1.0		9	ns
			V _{CCB} =3.3V±0.3V	1.5		8.1	1.0		9	ns
			V _{CCB} =5V±0.5V	1.5		8.1	1.0		9	ns
		V _{CCA} =3.3V ±0.3V	V _{CCB} =1.8V±0.15V	1.5		7.3	1.0		8.1	ns
			V _{CCB} =2.5V±0.2V	1.5		7.3	1.0		8.1	ns
			V _{CCB} =3.3V±0.3V	1.5		7.3	1.0		8.1	ns
			V _{CCB} =5V±0.5V	1.5		7.3	1.0		8.1	ns
		V _{CCA} =5V ±0.5V	V _{CCB} =1.8V±0.15V	1.5		5.4	1.0		6	ns
			V _{CCB} =2.5V±0.2V	1.5		5.4	1.0		6	ns
			V _{CCB} =3.3V±0.3V	1.5		5.5	1.0		6	ns
			V _{CCB} =5V±0.5V	1.5		5.4	1.0		6	ns
Propagation Delay From Input (DIR) to Output (B)	t _{PHZ}	V _{CCA} =1.8V ±0.15V	V _{CCB} =1.8V±0.15V	1.5		21.9	1.0		24.1	ns
			V _{CCB} =2.5V±0.2V	1.5		11.5	1.0		12.7	ns
			V _{CCB} =3.3V±0.3V	1.5		10.3	1.0		11.4	ns
			V _{CCB} =5V±0.5V	1.5		8.2	1.0		9.1	ns
		V _{CCA} =2.5V ±0.2V	V _{CCB} =1.8V±0.15V	1.5		23.7	1.0		23.6	ns
			V _{CCB} =2.5V±0.2V	1.5		11.4	1.0		12.1	ns
			V _{CCB} =3.3V±0.3V	1.5		10.2	1.0		10.3	ns
			V _{CCB} =5V±0.5V	1.5		7.1	1.0		7.6	ns
		V _{CCA} =3.3V ±0.3V	V _{CCB} =1.8V±0.15V	1.5		20.5	1.0		18.2	ns
			V _{CCB} =2.5V±0.2V	1.5		10.1	1.0		11.2	ns
			V _{CCB} =3.3V±0.3V	1.5		8.8	1.0		9.5	ns
			V _{CCB} =5V±0.5V	1.5		6.8	1.0		7.2	ns
		V _{CCA} =5V ±0.5V	V _{CCB} =1.8V±0.15V	1.5		20.2	1.0		17.8	ns
			V _{CCB} =2.5V±0.2V	1.5		9.8	1.0		10.7	ns
			V _{CCB} =3.3V±0.3V	1.5		8.5	1.0		9.2	ns
			V _{CCB} =5V±0.5V	1.5		6.5	1.0		7.2	ns

■ SWITCHING CHARACTERISTICS (Cont.)

PARAMETER	SYMBOL	TEST CONDITIONS	T _A =25°C			T _A =-40°C~+125°C			UNIT			
			MIN	TYP	MAX	MIN	TYP	MAX				
Propagation Delay From Input (DIR) to Output (A)	t _{PLZ}	V _{CCA} =1.8V ±0.15V	V _{CCB} =1.8V±0.15V	1.5		10.5	1.0		11.6	ns		
			V _{CCB} =2.5V±0.2V	1.5		10.5	1.0		11.6	ns		
			V _{CCB} =3.3V±0.3V	1.5		10.7	1.0		11.6	ns		
			V _{CCB} =5V±0.5V	1.5		10.9	1.0		11.6	ns		
		V _{CCA} =2.5V ±0.2V	V _{CCB} =1.8V±0.15V	1.0		5.9	0.5		6.4	ns		
			V _{CCB} =2.5V±0.2V	1.0		5.9	0.5		6.4	ns		
			V _{CCB} =3.3V±0.3V	1.0		5.9	0.5		6.4	ns		
		V _{CCA} =3.3V ±0.3V	V _{CCB} =1.8V±0.15V	1.5		5.6	1.0		6.2	ns		
			V _{CCB} =2.5V±0.2V	1.5		5.6	1.0		6.2	ns		
			V _{CCB} =3.3V±0.3V	1.5		5.7	1.0		6.2	ns		
		V _{CCA} =5V ±0.5V	V _{CCB} =1.8V±0.15V	1.5		5.7	1.0		6.2	ns		
			V _{CCB} =2.5V±0.2V	0.5		3.8	0.3		4.1	ns		
			V _{CCB} =3.3V±0.3V	0.5		3.8	0.3		4.1	ns		
			V _{CCB} =5V±0.5V	0.5		3.7	0.3		4.1	ns		
		Propagation Delay From Input (DIR) to Output (B)	t _{PLZ}	V _{CCA} =1.8V ±0.15V	V _{CCB} =1.8V±0.15V	1.5		16	1.0		17.6	ns
					V _{CCB} =2.5V±0.2V	1.5		9.2	1.0		10.2	ns
V _{CCB} =3.3V±0.3V	1.5					8.4	1.0		9.3	ns		
V _{CCB} =5V±0.5V	1.5					6.4	1.0		7.4	ns		
V _{CCA} =2.5V ±0.2V	V _{CCB} =1.8V±0.15V			1.5		18.9	1.0		20.6	ns		
	V _{CCB} =2.5V±0.2V			1.5		9.6	1.0		10.4	ns		
	V _{CCB} =3.3V±0.3V			1.5		8.4	1.0		9.3	ns		
V _{CCA} =3.3V ±0.3V	V _{CCB} =1.8V±0.15V			1.5		5.3	1.0		5.9	ns		
	V _{CCB} =2.5V±0.2V			1.5		14.5	1.0		15.8	ns		
	V _{CCB} =3.3V±0.3V			1.5		7.8	1.0		8.6	ns		
V _{CCA} =5V ±0.5V	V _{CCB} =2.5V±0.2V			1.5		7.1	1.0		7.9	ns		
	V _{CCB} =3.3V±0.3V			1.5		4.9	1.0		5.4	ns		
	V _{CCB} =1.8V±0.15V			1.5		14.8	1.0		16.4	ns		
	V _{CCB} =2.5V±0.2V			1.5		7.4	1.0		8.2	ns		
V _{CCA} =5V ±0.5V	V _{CCB} =3.3V±0.3V			1.5		7.0	1.0		7.7	ns		
	V _{CCB} =5V±0.5V			1.5		4.5	1.0		5	ns		
	V _{CCB} =1.8V±0.15V			33.7			37.1	ns				
	V _{CCB} =2.5V±0.2V			25.2			27.8	ns				
	V _{CCB} =3.3V±0.3V			23.9			26.4	ns				
Propagation Delay From Input (DIR) to Output (A)	t _{PZH}	V _{CCA} =1.8V ±0.15V	V _{CCB} =5V±0.5V			21.5			24.1	ns		
			V _{CCB} =1.8V±0.15V			29.2			32.9	ns		
			V _{CCB} =2.5V±0.2V			18.1			19.3	ns		
			V _{CCB} =3.3V±0.3V			16.4			18.1	ns		
		V _{CCA} =2.5V ±0.2V	V _{CCB} =5V±0.5V			12.8			14.2	ns		
			V _{CCB} =1.8V±0.15V			22.8			23.8	ns		
			V _{CCB} =2.5V±0.2V			14.2			15.5	ns		
		V _{CCA} =3.3V ±0.3V	V _{CCB} =3.3V±0.3V			12.9			14.1	ns		
			V _{CCB} =5V±0.5V			10.3			11.4	ns		
			V _{CCB} =1.8V±0.15V			22			23.9	ns		
		V _{CCA} =5V ±0.5V	V _{CCB} =2.5V±0.2V			12.5			13.5	ns		
			V _{CCB} =3.3V±0.3V			11.4			12.3	ns		
			V _{CCB} =5V±0.5V			8.4			9.3	ns		

■ SWITCHING CHARACTERISTICS (Cont.)

PARAMETER	SYMBOL	TEST CONDITIONS	T _A =25°C			T _A =-40°C~+125°C			UNIT			
			MIN	TYP	MAX	MIN	TYP	MAX				
Propagation Delay From Input (DIR) to Output (B)	t _{PZH}	V _{CCA} =1.8V ±0.15V	V _{CCB} =1.8V±0.15V			28.2			31.1	ns		
			V _{CCB} =2.5V±0.2V			20.8			21.9	ns		
			V _{CCB} =3.3V±0.3V			19			20.1	ns		
			V _{CCB} =5V±0.5V			18.1			19.1	ns		
		V _{CCA} =2.5V ±0.2V	V _{CCB} =1.8V±0.15V				21.9			24	ns	
			V _{CCB} =2.5V±0.2V				14.4			15.8	ns	
			V _{CCB} =3.3V±0.3V				12.3			13.3	ns	
		V _{CCA} =3.3V ±0.3V	V _{CCB} =5V±0.5V				10.9			11.7	ns	
			V _{CCB} =1.8V±0.15V				21.1			23.3	ns	
			V _{CCB} =2.5V±0.2V				13.6			15	ns	
		V _{CCA} =5V ±0.5V	V _{CCB} =3.3V±0.3V				11.5			12.4	ns	
			V _{CCB} =5V±0.5V				10.1			11.1	ns	
			V _{CCB} =1.8V±0.15V				18.9			20.8	ns	
		Propagation Delay From Input (DIR) to Output (A)	t _{PZL}	V _{CCA} =1.8V ±0.15V	V _{CCB} =1.8V±0.15V			36.2			39.9	ns
					V _{CCB} =2.5V±0.2V			24.4			26.9	ns
					V _{CCB} =3.3V±0.3V			22.9			25.3	ns
V _{CCB} =5V±0.5V						20.4			22.6	ns		
V _{CCA} =2.5V ±0.2V	V _{CCB} =1.8V±0.15V						32.2			33.8	ns	
	V _{CCB} =2.5V±0.2V						18.9			20.4	ns	
	V _{CCB} =3.3V±0.3V						17.2			18.5	ns	
V _{CCA} =3.3V ±0.3V	V _{CCB} =5V±0.5V						13.3			14.5	ns	
	V _{CCB} =1.8V±0.15V						27.6			29.1	ns	
	V _{CCB} =2.5V±0.2V						15.5			17.2	ns	
V _{CCA} =5V ±0.5V	V _{CCB} =3.3V±0.3V						13.8			15	ns	
	V _{CCB} =5V±0.5V						11.3			12	ns	
	V _{CCB} =1.8V±0.15V						27.2			28.5	ns	
Propagation Delay From Input (DIR) to Output (B)	t _{PZL}			V _{CCA} =1.8V ±0.15V	V _{CCB} =1.8V±0.15V			33.7			35.2	ns
					V _{CCB} =2.5V±0.2V			27			28.3	ns
					V _{CCB} =3.3V±0.3V			25.5			26.8	ns
		V _{CCB} =5V±0.5V				24.1			25.6	ns		
		V _{CCA} =2.5V ±0.2V	V _{CCB} =1.8V±0.15V				21			23.2	ns	
			V _{CCB} =2.5V±0.2V				15.6			17.3	ns	
			V _{CCB} =3.3V±0.3V				13.5			15	ns	
		V _{CCA} =3.3V ±0.3V	V _{CCB} =5V±0.5V				12.7			14.1	ns	
			V _{CCB} =1.8V±0.15V				19.9			22	ns	
			V _{CCB} =2.5V±0.2V				14.3			15.8	ns	
		V _{CCA} =5V ±0.5V	V _{CCB} =3.3V±0.3V				12.3			13.6	ns	
			V _{CCB} =5V±0.5V				11.3			12.5	ns	
			V _{CCB} =1.8V±0.15V				17.6			19.5	ns	
		V _{CCA} =5V ±0.5V	V _{CCB} =2.5V±0.2V				11.6			12.9	ns	
			V _{CCB} =3.3V±0.3V				10			11	ns	
				V _{CCB} =5V±0.5V						8.6	ns	

■ **OPERATING CHARACTERISTICS** ($T_A=25^\circ\text{C}$, unless otherwise specified)

PARAMETER		SYMBOL	TEST CONDITIONS	MIN	TYP	MAX	UNIT	
Input Capacitance	Control Inputs	C_{IN}	$V_I=V_{CCA}$ or GND		2.5		pF	
Output Capacitance	A or B Port	C_{IO}	$V_O=V_{CCA/B}$ or GND		6		pF	
Power Dissipation Capacitance	A Port Input B Port Output	C_{PDA}	$C_L=0, f=10\text{MHz}$ $t_r=t_f=1\text{nS}$	$V_{CCB}=1.8\text{V}$		3		pF
				$V_{CCB}=2.5\text{V}$		4		pF
				$V_{CCB}=3.3\text{V}$		4		pF
				$V_{CCB}=5\text{V}$		4		pF
	B Port Input A Port Output			$V_{CCB}=1.8\text{V}$		18		pF
				$V_{CCB}=2.5\text{V}$		19		pF
				$V_{CCB}=3.3\text{V}$		20		pF
				$V_{CCB}=5\text{V}$		21		pF
	A Port Input B Port Output	C_{PDB}		$V_{CCB}=1.8\text{V}$		18		pF
				$V_{CCB}=2.5\text{V}$		19		pF
				$V_{CCB}=3.3\text{V}$		20		pF
				$V_{CCB}=5\text{V}$		21		pF
	B Port Input A Port Output			$V_{CCB}=1.8\text{V}$		3		pF
				$V_{CCB}=2.5\text{V}$		4		pF
$V_{CCB}=3.3\text{V}$				4		pF		
$V_{CCB}=5\text{V}$				4		pF		

TEST CIRCUIT AND WAVEFORMS

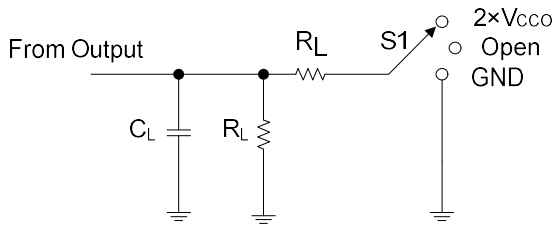

TEST	S1
t_{PD}	Open
t_{PLZ}/t_{PZL}	$2 \times V_{CCO}$
t_{PHZ}/t_{PZH}	GND

LOAD CIRCUIT

V_{CCO}	C_L	R_L	V_{TP}
$1.8V \pm 0.15V$	15pF	2k Ω	0.15V
$2.5V \pm 0.2V$	15pF	2k Ω	0.15V
$3.3V \pm 0.3V$	15pF	2k Ω	0.3V
$5V \pm 0.5V$	15pF	2k Ω	0.3V

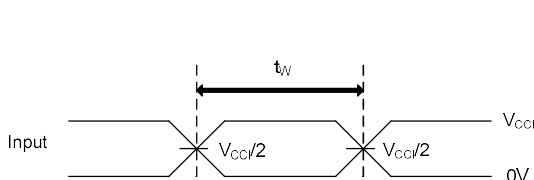

PULSE DURATION

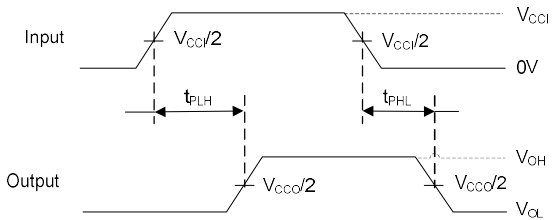

PROPAGATION DELAY TIMES

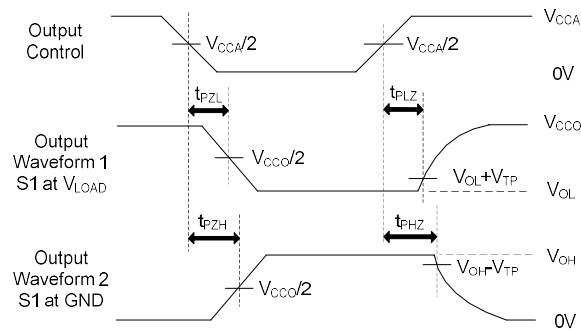

ENABLE AND DISABLE TIMES

Notes: 1. C_L includes probe and jig capacitance.

2. All input pulses are supplied by generators having the following characteristics: PRR \leq 10MHz, $Z_O = 50\Omega$, $dv/dt \geq 1V/ns$.

■ DETAILED DESCRIPTION

Overview

The **U74LVC1T45** is a single-bit, dual-supply, noninverting voltage level transceiver. Pin A and that direction control pin (DIR) are supported by V_{CCA} and pin B is supported by V_{CCB} . The A port is able to accept I/O voltages ranging from 1.65V to 5.5V, while the B port can accept I/O voltages from 1.65V to 5.5V. The high on the DIR allows data transmissions from A to B and a low on the DIR allows data transmissions from B to A.

■ FEATURES DESCRIPTION

Fully Configurable Dual-Rail Design Allows Each Port to Operate Over the Full 1.65V to 5.5V Power-Supply Range

Both V_{CCA} and V_{CCB} can be supplied at any voltage between 1.65V and 5.5V, making the device suitable for translating between any of the voltage nodes (1.8V, 2.5V, 3.3V, and 5V).

Support High Speed Translation

The **U74LVC1T45** device supports high data rate applications. The translated signal data rate can be up to 420Mbps when the signal is translated from 3.3V to 5V.

I_{OFF} Supports Partial Power-Down Mode Operation

I_{OFF} prevents backflow current by disabling I/O output circuits when device is in partial-power-down mode.

■ TYPICAL APPLICATION CIRCUIT

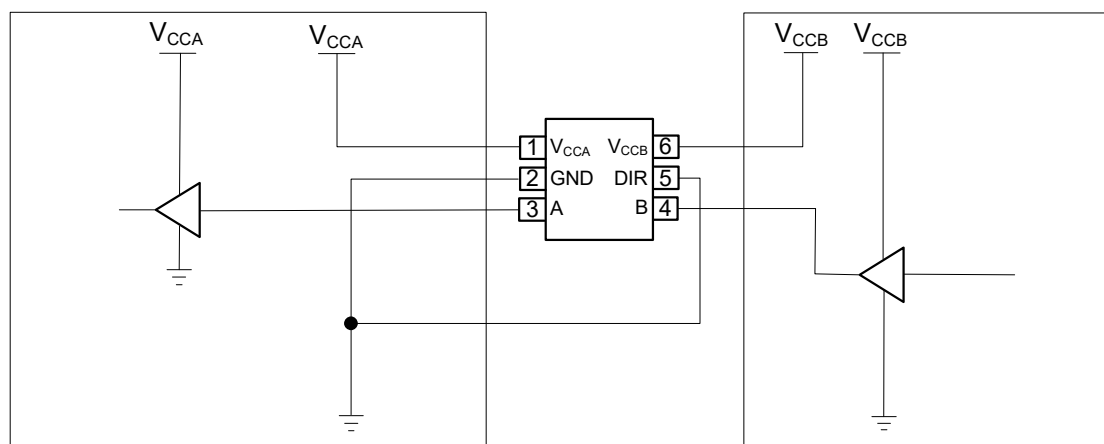

UTC assumes no responsibility for equipment failures that result from using products at values that exceed, even momentarily, rated values (such as maximum ratings, operating condition ranges, or other parameters) listed in products specifications of any and all UTC products described or contained herein. UTC products are not designed for use in life support appliances, devices or systems where malfunction of these products can be reasonably expected to result in personal injury. Reproduction in whole or in part is prohibited without the prior written consent of the copyright owner. UTC reserves the right to make changes to information published in this document, including without limitation specifications and product descriptions, at any time and without notice. This document supersedes and replaces all information supplied prior to the publication hereof.