



2N4403-Q

PNP SILICON TRANSISTOR

PNP GENERAL PURPOSE AMPLIFIER

DESCRIPTION

The UTC 2N4403-Q is designed for use as a general purpose amplifier and switch requiring collector currents up to 500mA.

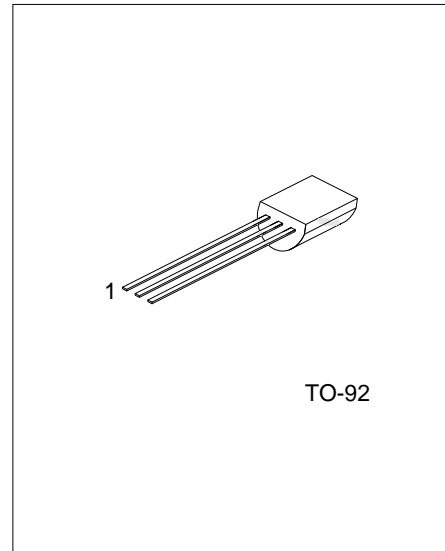

ORDERING INFORMATION

Ordering Number		Package	Pin Assignment			Packing
Lead Free	Halogen Free		1	2	3	
2N4403L-Q-T92-B	2N4403G-Q-T92-B	TO-92	E	B	C	Tape Box
2N4403L-Q-T92-K	2N4403G-Q-T92-K	TO-92	E	B	C	Bulk

Note: Pin Assignment: E: Emitter B: Base C: Collector

<p>2N4403G-Q-AE3-R</p> <p>(1) Packing Type</p> <p>(2) Package Type</p> <p>(3) Green Package</p>	<p>(1) B: Tape Box, K: Bulk</p> <p>(2) T92: TO-92</p> <p>(3) G: Halogen Free and Lead Free, L: Lead Free</p>
---	--

MARKING

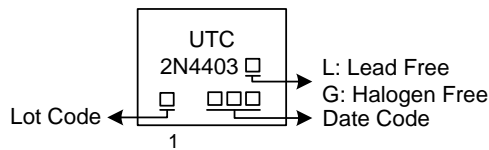

■ **ABSOLUTE MAXIMUM RATINGS** ($T_A=25^\circ\text{C}$, unless otherwise specified)

PARAMETER	SYMBOL	RATINGS	UNIT
Collector-Base Voltage	V_{CBO}	-40	V
Collector-Emitter Voltage	V_{CEO}	-40	V
Emitter-Base Voltage	V_{EBO}	-5	V
Collector Current-Continuous	I_C	-600	mA
Total Device Dissipation	P_C	625	mW
Derate above 25°C		5.0	mW/ $^\circ\text{C}$
Junction Temperature	T_J	+150	$^\circ\text{C}$
Storage Temperature	T_{STG}	-55 ~ +150	$^\circ\text{C}$

- Notes: 1. Absolute maximum ratings are those values beyond which the device could be permanently damaged. Absolute maximum ratings are stress ratings only and functional device operation is not implied.
 2. These are steady state limits. The factory should be consulted on applications involving pulsed or low duty cycle operations.

■ **THERMAL DATA** ($T_A=25^\circ\text{C}$, unless otherwise specified)

CHARACTERISTIC	SYMBOL	RATINGS	UNIT
Junction to Ambient	θ_{JA}	200	$^\circ\text{C}/\text{W}$
Junction to Case	θ_{JC}	83.3	$^\circ\text{C}/\text{W}$

■ **ELECTRICAL CHARACTERISTICS** ($T_A=25^\circ\text{C}$, unless otherwise specified)

PARAMETER	SYMBOL	TEST CONDITIONS	MIN	TYP	MAX	UNIT
OFF CHARACTERISTICS						
Collector-Emitter Breakdown Voltage (Note)	BV_{CEO}	$I_C=-1\text{mA}, I_B=0$	-40			V
Collector-Base Breakdown Voltage	BV_{CBO}	$I_C=-0.1\text{mA}, I_E=0$	-40			V
Emitter-Base Breakdown Voltage	BV_{EBO}	$I_E=-0.1\text{mA}, I_C=0$	-5			V
Collector-Base Cutoff Current	I_{CBO}	$V_{CE}=-40\text{V}, I_E=0$			-0.1	μA
Collector-Emitter Cutoff Current	I_{CEO}	$V_{CE}=-40\text{V}, I_B=0$			-0.1	μA
Emitter-Base Cutoff Current	I_{EBO}	$V_{EB}=-5\text{V}, I_C=0$			-0.1	μA
ON CHARACTERISTICS*						
DC Current Gain	h_{FE1}	$V_{CE}=-1\text{V}, I_C=-0.1\text{mA}$	30			
	h_{FE2}	$V_{CE}=-1\text{V}, I_C=-1\text{mA}$	60			
	h_{FE3}	$V_{CE}=-1\text{V}, I_C=-10\text{mA}$	100			
	h_{FE4}	$V_{CE}=-2\text{V}, I_C=-150\text{mA}$ (Note)	100		300	
	h_{FE5}	$V_{CE}=-2\text{V}, I_C=-500\text{mA}$ (Note)	20			
Collector-Emitter Saturation Voltage	$V_{CE(SAT1)}$	$I_C=-150\text{mA}, I_B=-15\text{mA}$			-0.4	V
	$V_{CE(SAT2)}$	$I_C=-500\text{mA}, I_B=-50\text{mA}$			-0.75	
Base-Emitter Saturation Voltage	$V_{BE(SAT1)}$	$I_C=-150\text{mA}, I_B=-15\text{mA}$ (Note)	-0.75		-0.95	V
	$V_{BE(SAT2)}$	$I_C=-500\text{mA}, I_B=-50\text{mA}$			-1.3	

Note: Pulse test: Pulse Width $\leq 300\mu\text{s}$, Duty Cycle $\leq 2\%$.

TYPICAL CHARACTERISTICS

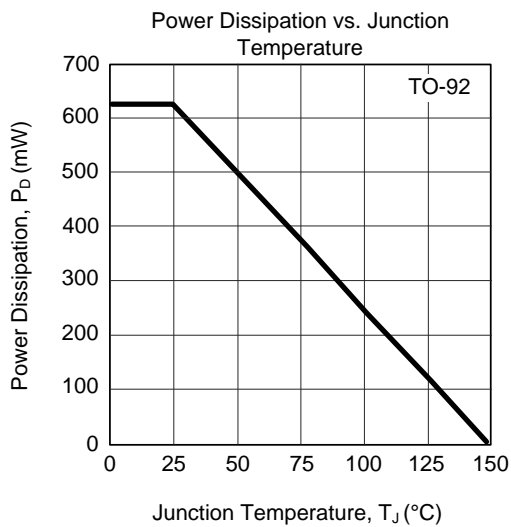
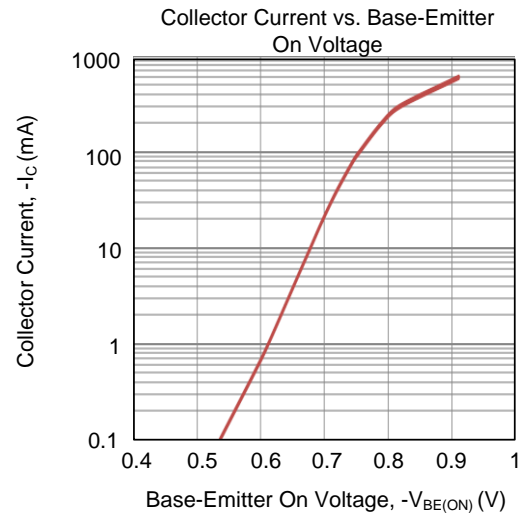
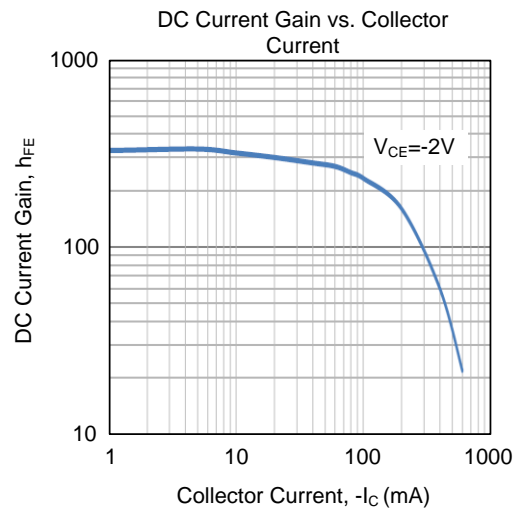
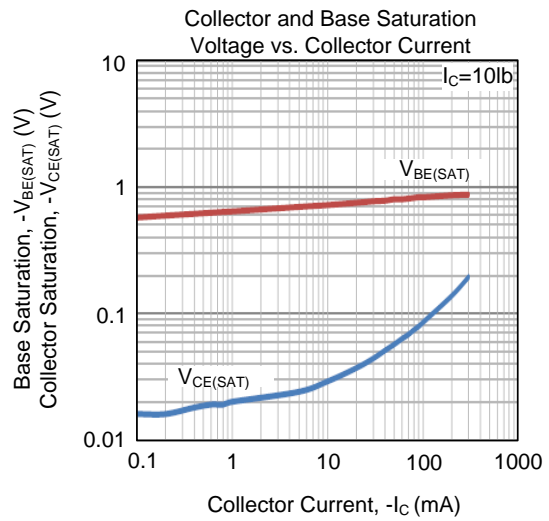
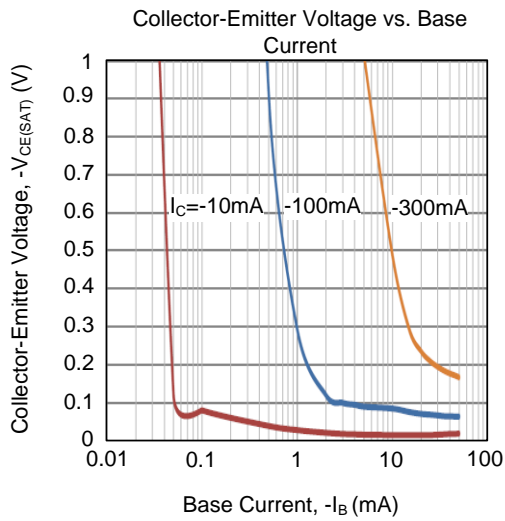

UTC assumes no responsibility for equipment failures that result from using products at values that exceed, even momentarily, rated values (such as maximum ratings, operating condition ranges, or other parameters) listed in products specifications of any and all UTC products described or contained herein. UTC products are not designed for use in life support appliances, devices or systems where malfunction of these products can be reasonably expected to result in personal injury. Reproduction in whole or in part is prohibited without the prior written consent of the copyright owner. UTC reserves the right to make changes to information published in this document, including without limitation specifications and product descriptions, at any time and without notice. This document supersedes and replaces all information supplied prior to the publication hereof.