



1.4A BOOST FOR WHITE LED DRIVER

DESCRIPTION

The UTC **L5104** is a high frequency, asynchronous boost converter. The internal MOSFET can support up to 8 White LEDs for backlighting and OLED power application, and the internal soft start function can reduce the inrush current.

The UTC **L5104** uses current mode, 1.0MHz fixed frequency architecture to regulate the LED current, which is set through an external current sense resistor. Its low 300mV feedback voltage reduces power loss and improves efficiency. The OVP pin monitors the output voltage and turns off the converter if an over-voltage condition is present due to an open circuit condition. The UTC **L5104** includes under-voltage lockout, current limiting and thermal shutdown protection preventing damage in the event of an output overload.

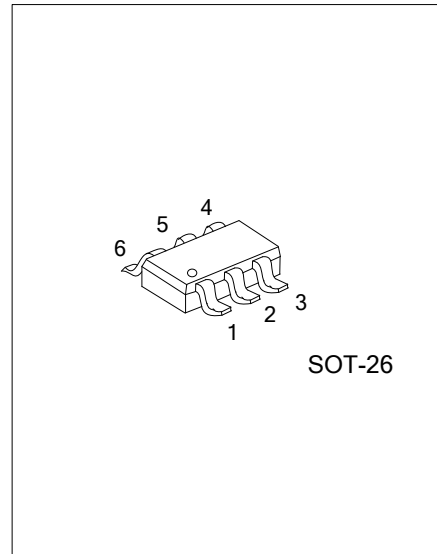

FEATURES

- * 2.5V~5.5V operating input voltage range
- * Drives up to 8 series White LEDs
- * 1.0MHz Fixed Switching Frequency
- * Wide range for PWM dimming (200Hz~200KHz)
- * Internal 1.4A switching current limit
- * Over Voltage Protection (OVP)
- * Internal Soft-start Function
- * Current limit and Thermal shutdown protection
- * Under voltage Lockout

ORDERING INFORMATION

Ordering Number		Package	Packing
Lead Free	Halogen Free		
L5104L-AG6-R	L5104G-AG6-R	SOT-26	Tape Reel

<p>L5104G-AG6-R</p> <ul style="list-style-type: none"> (1)Packing Type (2)Package Type (3)Green Package 	<ul style="list-style-type: none"> (1) R: Tape Reel (2) AG6: SOT-26 (3) G: Halogen Free and Lead Free, L: Lead Free
--	--

MARKING

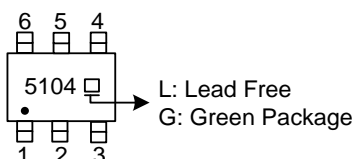

■ PIN CONFIGURATION

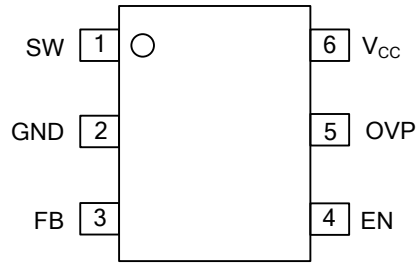

■ PIN DESCRIPTION

PIN NO.	PIN NAME	DESCRIPTION
1	SW	Switching Pin.
2	GND	Ground Pin.
3	FB	Feedback Pin.
4	EN	Chip Enable & Dimming pin. Active high. Internal pull low.
5	OVP	Over voltage detect pin.
6	V _{CC}	Power Input Pin.

■ BLOCK DIAGRAM

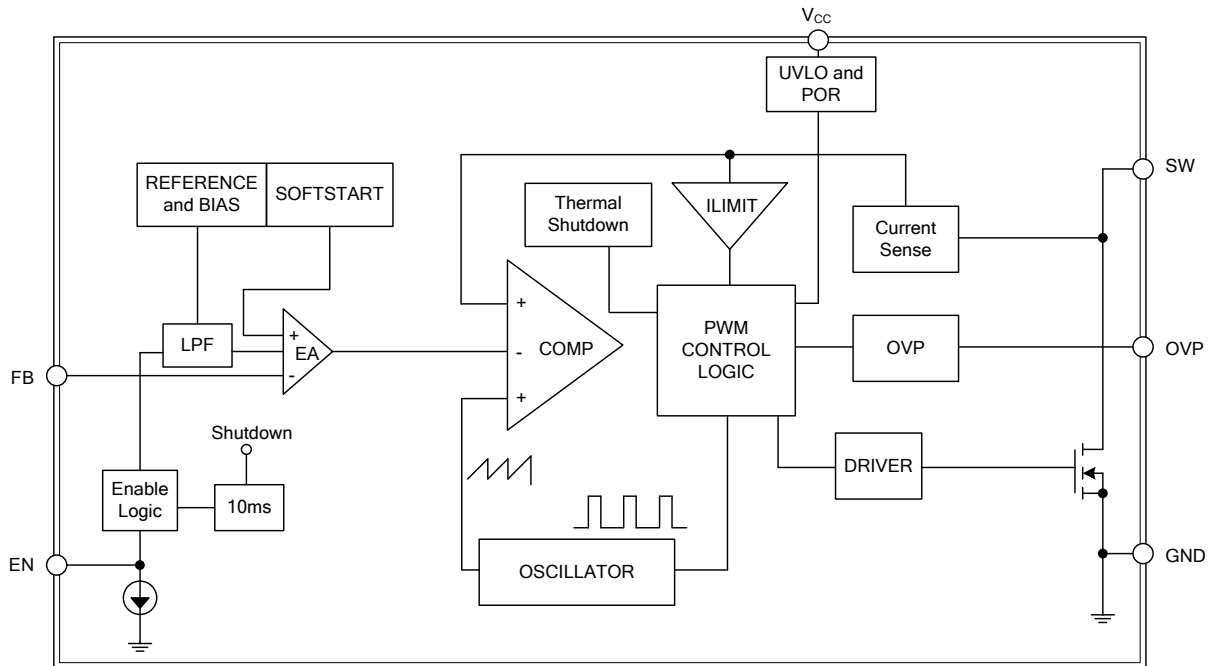

■ ABSOLUTE MAXIMUM RATING ($T_A=25^{\circ}\text{C}$, unless otherwise specified)

PARAMETER	SYMBOL	RATINGS	UNIT
V _{CC} Pin Voltage	V _{IN}	6	V
SW Pin Voltage	V _{SW}	33	V
OVP Pin Voltage	V _{OVP}	33	V
EN, FB Pins Voltage		V _{IN} +0.3	V
Operating Junction Temperature	T _{OPR}	-40 ~ +125	°C
Storage Temperature Range	T _{STG}	-65 ~ +150	°C

Note: Absolute maximum ratings are those values beyond which the device could be permanently damaged. Absolute maximum ratings are stress ratings only and functional device operation is not implied.

■ RECOMMENDED OPERATING CONDITIONS

PARAMETER	SYMBOL	RATINGS	UNIT
Input Supply Voltage	V _{IN}	2.5 ~ 5.5	V

■ THERMAL CHARACTERISTICS

PARAMETER	SYMBOL	RATINGS	UNIT
Junction To Ambient	θ_{JA}	250	°C/W

Note: θ_{JA} is measured with the PCB copper are (need connect to GND of the UTC L5104) of approximately 1 in² (Multi-layer).

■ ELECTRICAL CHARACTERISTICS (V_{IN}=5V, V_{EN}=5V, I_{OUT}=20mA, T_A=25°C)

PARAMETER	SYMBOL	TEST CONDITIONS	MIN	TYP	MAX	UNIT
Input Voltage Range	V _{IN}		2.5		5.5	V
Input UVLO	UVLO	Rising		2.25	2.45	V
UVLO Hysteresis				0.1		V
OVP Sense Voltage	V _{OV}		27.5	29		V
Quiescent Current	I _{CCQ}	V _{FB} =0.5V, I _{OUT} =0mA		200	400	μA
Supply Current	I _{IN}	V _{FB} =0V, Switching		1	2	mA
Shutdown Current	I _{SD}	V _{EN} =0V, T _{EN} >20mS		1	4	μA
FB Pin Voltage	V _{FB}		0.285	0.300	0.315	V
FB Pin Current	I _{FB}				±100	nA
Load Regulation		1mA<I _{OUT} <20mA		1		%
Line Regulation		3V<V _{IN} <4.3V		1		%
EN Pin Voltage High	V _{ENH}		1.4			V
EN Pin Voltage Low	V _{ENL}				0.4	V
EN Hysteresis				0.1		V
EN Pin Sink Current	I _{IH}			1		μA
Switching Frequency	F _{OSC}		0.75	1	1.25	MHz
N-Channel MOSFET Current Limit (Note)	C _L			1.4		A
	C _L	Duty on 50%		1.9		A
Switching Maximum Duty	D _{MAX}			92		%
Dimming Clock Rate			0.2		200	KHz
N-Switch R _{DS(ON)}	R _{DS(ON)-N}	V _{IN} =3.6V		0.5	1.0	Ω
Thermal Shutdown	T _{SD}			150		°C
Thermal Shutdown Protection Hysteresis	T _{SH}			25		°C

Note: Guaranteed by design.

■ FUNCTION DESCRIPTION

Setting the ILED Current

Application circuit item shows the basic application circuit with UTC **L5104** adjustable output version. The external resistor sets the LED output current according to the following equation:

I _{LED}	REST	
20mA	15Ω	6mW
350mA	0.857Ω	105mW

Under Voltage Lockout (UVLO)

To avoid mis-operation of the device at low input voltages an under voltage lockout is included that disables the device, if the input voltage falls below (2.25V~100mV).

Over Voltage Protection

OVP measure the output voltage for open circuit protection. Connect OVP pin to the output at the top of the LED string. If V_{OUT} above 36V, the OVP protection is happened that stops the internal driver until V_{OUT} below 36V.

Input Capacitor Selection

The input capacitor reduces the surge current drawn from the input and switching noise from the device. The input capacitor impedance at the switching frequency shall be less than input source impedance to prevent high frequency switching current passing to the input. A low ESR input capacitor sized for maximum RMS current must be used. Ceramic capacitors with X5R or X7R dielectrics are highly recommended because of their low ESR and small temperature coefficients. A 2.2uF ceramic capacitor for most applications is sufficient. For a lower output power requirement application, this value can be decreased.

Output Capacitor Selection

The output capacitor is required to keep the output voltage ripple small and to ensure regulation loop stability. The output capacitor must have low impedance at the switching frequency. Ceramic capacitors with X5R or X7R dielectrics are recommended due to their low ESR and high ripple current. A 1uF ceramic capacitors works for most of the applications. Higher capacitor values can be used to improve the load transient response.

■ TYPICAL APPLICATION CIRCUIT

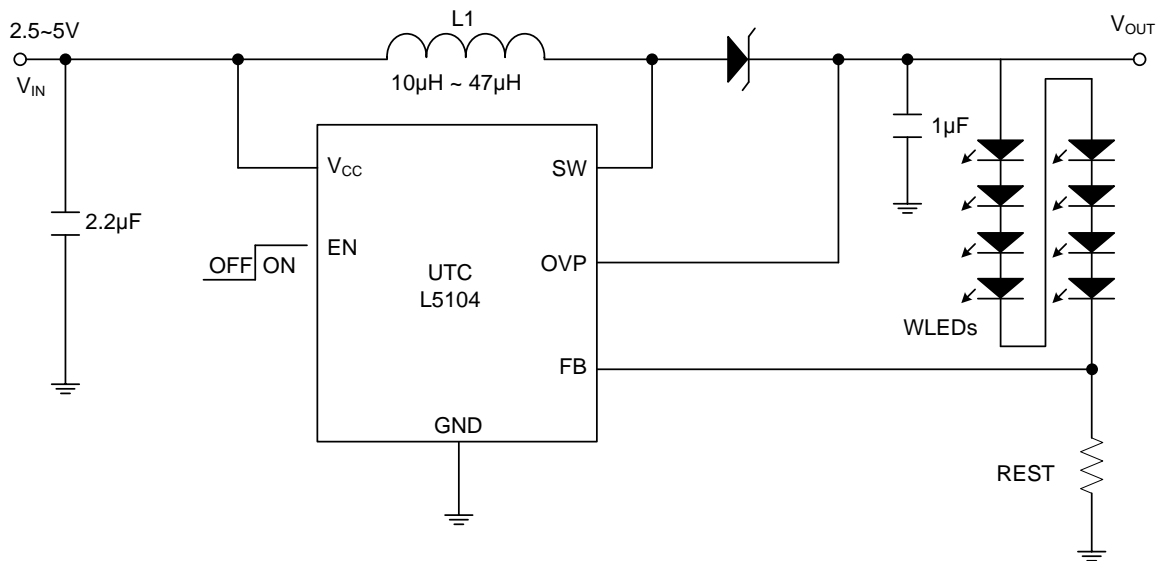

UTC assumes no responsibility for equipment failures that result from using products at values that exceed, even momentarily, rated values (such as maximum ratings, operating condition ranges, or other parameters) listed in products specifications of any and all UTC products described or contained herein. UTC products are not designed for use in life support appliances, devices or systems where malfunction of these products can be reasonably expected to result in personal injury. Reproduction in whole or in part is prohibited without the prior written consent of the copyright owner. UTC reserves the right to make changes to information published in this document, including without limitation specifications and product descriptions, at any time and without notice. This document supersedes and replaces all information supplied prior to the publication hereof.