



UBCR302

Preliminary

TRIACS

2A TRIAC

DESCRIPTION

The UTC **UBCR302** is a 2A triacs which can be operated in 3 quadrants only, it uses UTC's advanced technology to provide customers with high commutation performances, etc.

The UTC **UBCR302** is suitable for use in electric pot, electric rice cooker and controller for other heater.

FEATURES

- * $I_{T(RMS)}$: 2A
- * V_{DRM} : 800V ($T_J=125^{\circ}C$)
- * $I_{GT\ I-II-III}$: 10mA

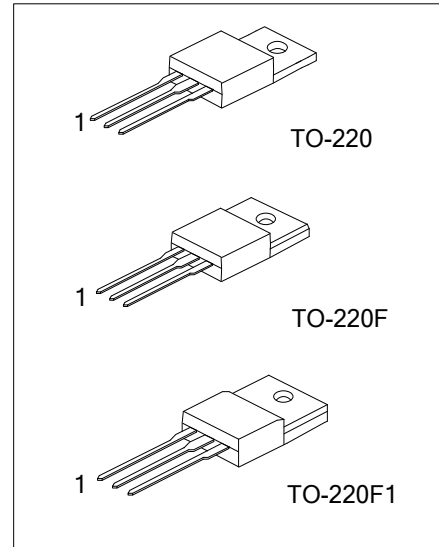

SYMBOL

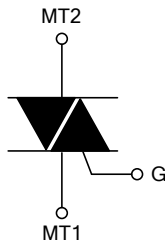

ORDERING INFORMATION

Ordering Number		Package	Pin Assignment			Packing
Lead Free	Halogen Free		1	2	3	
UBCR302L-x-TA3-T	UBCR302G-x-TA3-T	TO-220	MT1	MT2	G	Tube
UBCR302L-x-TF1-T	UBCR302G-x-TF1-T	TO-220F1	MT1	MT2	G	Tube
UBCR302L-x-TF3-T	UBCR302G-x-TF3-T	TO-220F	MT1	MT2	G	Tube

Note: Pin Assignment: MT1: MT1 MT2: MT2 G: Gate

<p>UBCR302G-x-TA3-T</p> <p>(1) Packing Type (2) Package Type (3) V_{DRM} (4) Green Package</p>	<p>(1) T: Tube (2) TA3: TO-220, TF3: TO-220F, TF1: TO-220F1 (3) 8: 800V (4) G: Halogen Free and Lead Free, L: Lead Free</p>
---	---

MARKING

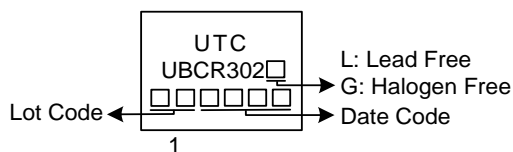

■ ABSOLUTE MAXIMUM RATINGS

PARAMETER	SYMBOL	RATINGS	UNIT
Repetitive Peak Off-State Voltage (Note 1)	V_{DRM} / V_{RRM}	800	V
On-State RMS Current (Commercial Frequency, Sine Full Wave 360° Conduction)	$I_{T(RMS)}$	2	A
Surge On-State Current (60Hz Sinewave 1 Full Cycle, Peak Value, Non-Repetitive)	I_{TSM}	10	A
I^2t for Fusing (Value Corresponding to 1 Cycle of Half Wave 60Hz, Surge On-State Current)	I^2t	0.41	A ² s
Peak Gate Current	I_{GM}	1	A
Peak Gate Power Dissipation	P_{GM}	1	W
Average Gate Power Dissipation	$P_{G(AV)}$	0.1	W
Peak Gate Voltage	V_{GM}	6	V
Operating Junction Temperature	T_J	-40 ~ +125	°C
Storage Junction Temperature	T_{STG}	-40 ~ +150	°C

Note: Absolute maximum ratings are those values beyond which the device could be permanently damaged. Absolute maximum ratings are stress ratings only and functional device operation is not implied.

■ THERMAL DATA

PARAMETER	SYMBOL	RATINGS	UNIT
Junction to Case	TO-220	3.2	°C/W
	TO-220F/TO-220F1	5.2	°C/W

■ ELECTRICAL CHARACTERISTICS ($T_J=25\text{ }^\circ\text{C}$, unless otherwise specified)

PARAMETER	SYMBOL	TEST CONDITIONS	MIN	TYP	MAX	UNIT	
Gate Trigger Current (Note 2)	I_{GT}	$T_J=25^\circ\text{C}$, $V_D=6\text{V}$, $R_L=6\Omega$, $R_G=330\Omega$	I			10	mA
			II			10	mA
			III			10	mA
Gate Trigger Voltage (Note 2)	V_{GT}	$T_J=25^\circ\text{C}$, $V_D=6\text{V}$, $R_L=6\Omega$, $R_G=330\Omega$	I			2.0	V
			II			2.0	V
			III			2.0	V
Gate Non-Trigger Voltage	V_{GD}	$T_J=150^\circ\text{C}$, $V_D=1/2 V_{DRM}$	0.1			V	
Holding Current (Note 2)	I_H	$I_T=300\text{mA}$		2.98		mA	
Latching Current	I_L	$I_G=1.2I_{GT}$	I-II		5	mA	
			II		10	mA	
Critical Rate of Rise of Off-State commutation Voltage (Note 3)	$(dv/dt)_c$	$T_J=125^\circ\text{C}$	0.5			V/ μs	

■ STATIC CHARACTERISTICS

PARAMETER	SYMBOL	TEST CONDITIONS	MIN	TYP	MAX	UNIT
On-State Voltage	V_{TM}	$T_J=25^\circ\text{C}$, $I_{TM}=3\text{A}$, Instantaneous Measurement			2.1	V
Repetitive Peak Off-State Current	I_{DRM}	$T_J=150^\circ\text{C}$, V_{DRM} Applied			1.0	mA

Notes: 1. Gate open.

2. Measurement using the gate trigger characteristics measurement circuit.

3. Test conditions of the critical-rate of rise of off-state commutation voltage is shown in the table below.

■ **COMMUTATING VOLTAGE AND CURRENT WAVEFORMS (INDUCTIVE LOAD)**

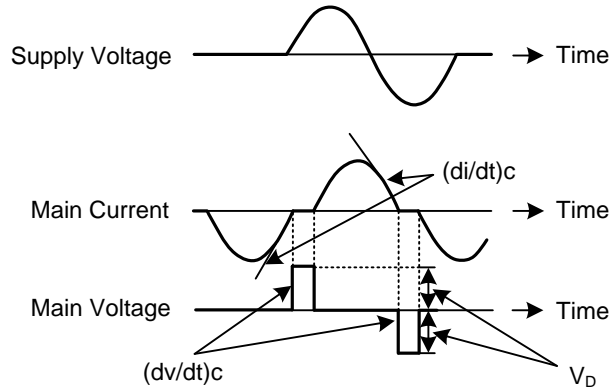

Note: Test Conditions: 1. Junction temperature: $T_J=125^\circ\text{C}$
 2. Rate of decay of on-state commutating current: $(di/dt)_c=-1.0\text{A/ms}$
 3. Peak off-state voltage: $V_D=400\text{V}$

■ **TEST CIRCUITS**

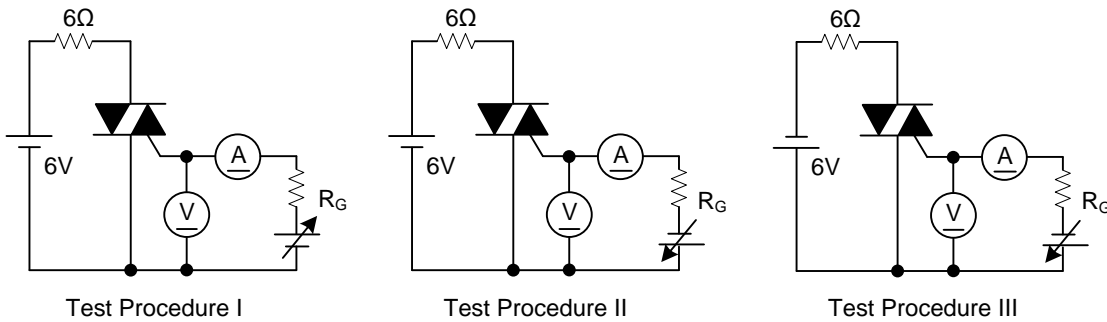

UTC assumes no responsibility for equipment failures that result from using products at values that exceed, even momentarily, rated values (such as maximum ratings, operating condition ranges, or other parameters) listed in products specifications of any and all UTC products described or contained herein. UTC products are not designed for use in life support appliances, devices or systems where malfunction of these products can be reasonably expected to result in personal injury. Reproduction in whole or in part is prohibited without the prior written consent of the copyright owner. UTC reserves the right to make changes to information published in this document, including without limitation specifications and product descriptions, at any time and without notice. This document supersedes and replaces all information supplied prior to the publication hereof.