

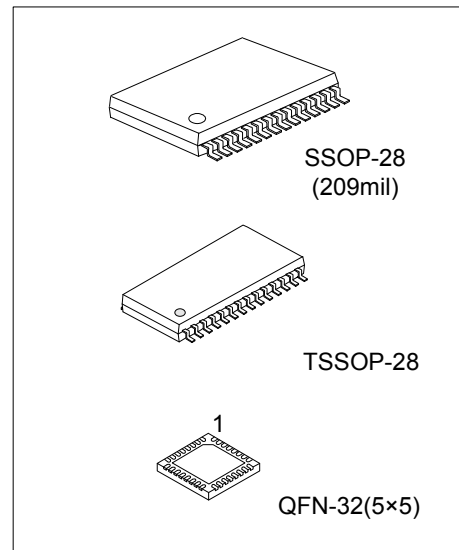

UT5232

CMOS IC

+3.0V TO +5.5V POWER SUPPLY, 235KBPS, MULTICHANNEL RS-232 LINE DRIVERS/RECEIVERS



DESCRIPTION

The UTC **UT5232** consists of 3 drivers and 5 receivers. It meets EIA/TIA-232 and V.28/V.24 specifications, it intended for notebook computer applications. A high-efficiency, dual charge-pumps power supply and a low-dropout transmitter combine to deliver true RS-232 performance from a single +3.0V ~ +5.5V power supply. A guaranteed data rate of 120kbps provides compatibility with popular software for communicating with PCs.

The UTC **UT5232** achieves 1µA supply current in shutdown condition. When the **UT5232** doesn't detect a valid signal level on its receiver inputs, the on-board power supply and drivers will shutdown, and when a valid level is applied to any RS-232 receiver input, then the system turns on again. Therefore, the system saves power without changes to the existing BIOS or operating system.

The UTC **UT5232** requires only 0.1µF capacitors in 3.3V operation, and can operate from input voltages ranging from +3.0V ~ +5.5V. It is ideal for 3.3V-only systems, 5.0V-only systems, or mixed 3.3V and 5.0V systems that require true RS-232 performance.

The UTC **UT5232** includes one complementary always-active receiver that can monitor an external device (such as a modem) in shutdown, without forward biasing the protection diodes in a UART that may have V_{CC} completely removed.

FEATURES

- * Operates With 3.0V ~ 5.5V Power Supply
- * Three Drivers and Five Receivers
- * Operates Up To 235 kbps
- * Designed to Transmit at a Data Rate of 235 kbps
- * Low Standby Current (1uA Typical)
- * External Capacitors (4×0.1µF)
- * Accepts 5.0V Logic Input With 3.3V Supply
- * Always-Active Non-inverting Receiver Output (R_{2OUTB})
- * Serial-Mouse Drivability
- * ESD(HBM) Protected ±15KV(MIN.) for RS-232 Pins

ORDERING INFORMATION

Ordering Number		Package	Packing
Lead Free	Halogen Free		
UT5232L-P28-R	UT5232G-P28-R	TSSOP-28	Tape Reel
UT5232L-R28-R	UT5232G-R28-R	SSOP-28	Tape Reel
UT5232L-Q32-5050-R	UT5232G-Q32-5050-R	QFN-32(5×5)	Tape Reel

<p>UT5232G-P28-R</p> <p>(1)Packing Type (2)Package Type (3)Green Package</p>	<p>(1) R: Tape Reel (2) P28: TSSOP-28, R28: SSOP-28 Q32-5050: QFN-32(5×5) (3) G: Halogen Free and Lead Free, L: Lead Free</p>
--	---

■ MARKING

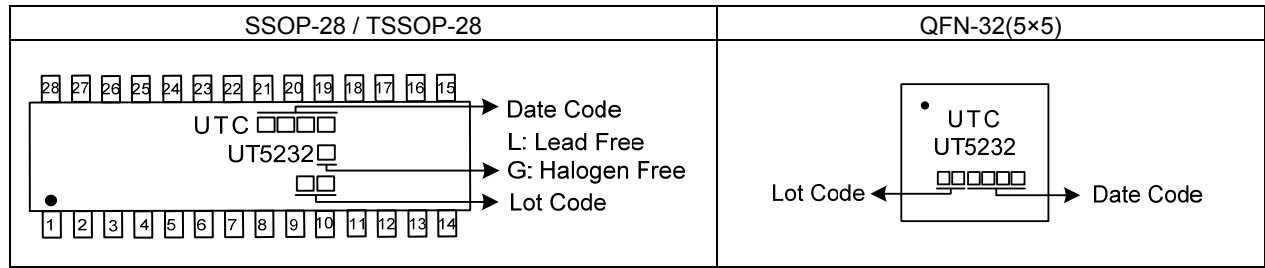

PIN CONFIGURATION

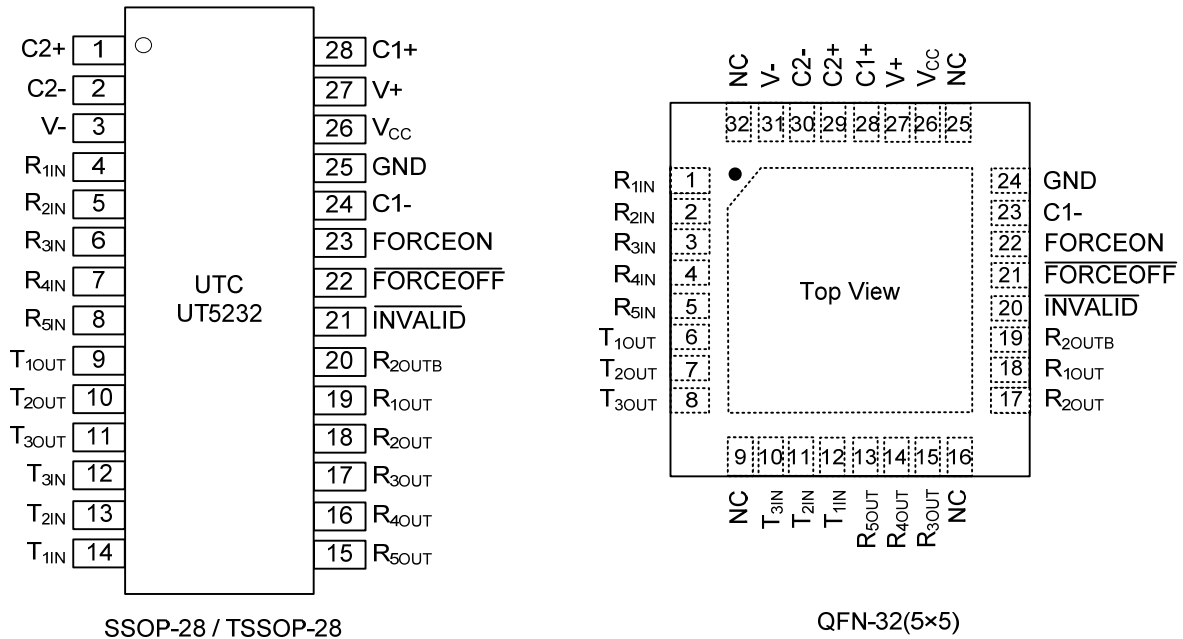

PIN DESCRIPTION

PIN NO.		PIN NAME	DESCRIPTION
SSOP-28 TSSOP-28	QFN-32(5x5)		
1	29	C2+	Positive terminal of inverting charge-pump capacitor
2	30	C2-	Negative terminal of inverting charge-pump capacitor
3	31	V-	-5.5V generated by the charge pump
4~8	1~5	R _{XIN}	RS-232 Receiver Inputs
9~11	6~8	T _{XOUT}	RS-232 Transmitter Outputs
12~14	10~12	T _{XIN}	TTL/CMOS Transmitter Inputs
15~19	13~15, 7~18	R _{XOUT}	TTL/CMOS Receiver Outputs
20	17	R _{2OUTB}	Noninverting Receiver Output—active in shutdown
21	20	$\overline{\text{INVALID}}$	Output of the valid signal detector. Indicates if a valid RS-232 level is present on receiver inputs logic “1”.
22	21	$\overline{\text{FORCEOFF}}$	Drive low to shut down transmitters and on-board power supply. This over-rides all automatic circuitry and FORCEON (Table 1).
23	22	FORCEON	Drive high to override automatic circuitry keeping transmitters on ($\overline{\text{FORCEOFF}}$ must be high) (Table 1).
24	23	C1-	Negative terminal of the voltage doubler charge-pump capacitor
25	24	GND	Ground
26	26	V _{CC}	+3.0V ~ +5.5V Supply Voltage
27	27	V+	+5.5V generated by the charge pump
28	28	C1+	Positive terminal of the voltage doubler charge-pump capacitor
-	9, 16, 25, 32	NC	No Connect

■ BLOCK DIAGRAM

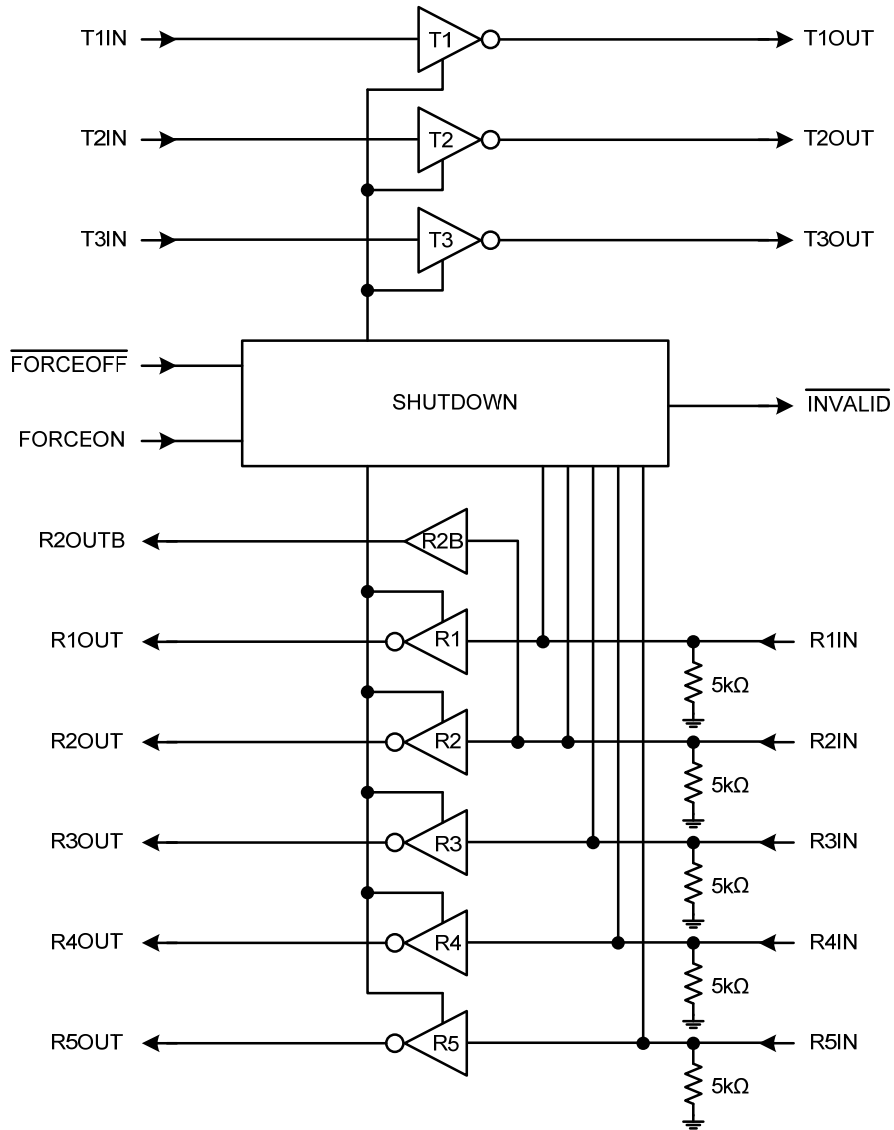

■ ABSOLUTE MAXIMUM RATING

PARAMETER		SYMBOL	RATINGS	UNIT
V _{CC}		V _{CC}	6	V
V+ (Note 2)		V+	7	V
V- (Note 2)		V-	-7	V
V+ + V- (Note 2)		V _{PUMP}	+13	V
Input Voltages	T_IN, $\overline{\text{FORCEOFF}}$, FORCEON	V _{IN}	6	V
	R_IN		±25	V
Output Voltages	T_OUT	V _{OUT}	±13.2	V
	R_OUT, $\overline{\text{INVALID}}$		V _{CC}	V
Short-Circuit Duration	T_OUT	SC	Continuous	
Operating Temperature		T _{OPR}	-40 ~ +85	°C
Storage Temperature		T _{STG}	-65 ~ +150	°C

Notes: 1. Absolute maximum ratings are those values beyond which the device could be permanently damaged. Absolute maximum ratings are stress ratings only and functional device operation is not implied.
 2. V+ and V- can have maximum magnitudes of 7V, but their absolute difference cannot exceed 13V.

■ THERMAL DATA

PARAMETER		SYMBOL	RATINGS	UNIT
Junction to Ambient	SSOP-28/TSSOP-28	θ_{JA}	63	°C/W
	QFN-32(5×5)		38	°C/W

Note: On PCB test.

■ ELECTRICAL CHARACTERISTICS

(V_{CC} = +3.0V~+5.5V, C1~C4=0.1μF (Note 1, 2), T_A = T_{MIN} to T_{MAX}, unless otherwise specified)

PARAMETER	SYMBOL	TEST CONDITIONS	MIN	TYP	MAX	UNIT		
DC CHARACTERISTICS								
Supply Current, Shutdown	I _{SHDN}	V _{CC} = 3.3V or 5.0V, T _A = 25°C	All R_IN open, $\overline{\text{FORCEOFF}} = V_{CC}$, FORCEON = GND		1.0	10	μA	
			$\overline{\text{FORCEOFF}} = \text{GND}$		1.0	10	μA	
Supply Current, Shutdown Disabled	I _{CC}	T _A = 25°C	FORCEON = $\overline{\text{FORCEOFF}} = V_{CC}$, no load		0.3	1	mA	
LOGIC INPUTS AND RECEIVER OUTPUTS								
Input Logic Threshold	Low	V _{LGL}	T_IN, FORCEON, $\overline{\text{FORCEOFF}}$			0.8	V	
	High	V _{LGH}	T_IN, EN, FORCEON, $\overline{\text{FORCEOFF}}$	V _{CC} = 3.3V V _{CC} = 5.0V	2.0 2.4		V	
Input Leakage Current	I _{IN(LK)}		T_IN, EN, FORCEON, $\overline{\text{FORCEOFF}}$		±0.01	±1.0	μA	
Output Leakage Current	I _{ROUT(LK)}		Receivers disabled		±0.05	±10	μA	
Output Voltage	Low	V _{ROUTL}	I _{OUT} = 1.6mA			0.4	V	
	High	V _{ROUTH}	I _{OUT} = -1.0mA	V _{CC} - 0.6	V _{CC} - 0.1		V	
SHUTDOWN (FORCEON = GND, $\overline{\text{FORCEOFF}} = V_{CC}$)								
Receiver Input Thresholds to Transmitters	Enabled	V _{R(EN)}	Fig.1	Positive threshold			2.7	V
	Disabled	V _{R(DIS)}	1μA supply current, Fig.1	Negative threshold	-2.7			V
$\overline{\text{INVALID}}$ Output Voltage	Low	V _{INVL}	I _{OUT} = 1.6mA			0.4	V	
	High	V _{INVH}	I _{OUT} = -1.0mA	V _{CC} - 0.6			V	
Receiver Threshold to Transmitters Enabled	t _{WU}		Fig.2		250		μs	

■ ELECTRICAL CHARACTERISTICS(Cont.)

($V_{CC} = +3.0V \sim +5.5V$, $C1 \sim C4 = 0.1\mu F$ (Note 1, 2), $T_A = T_{MIN}$ to T_{MAX} , Unless Otherwise Specified)

PARAMETER		SYMBOL	TEST CONDITIONS	MIN	TYP	MAX	UNIT	
Receiver Positive or Negative Threshold to INVALID	High	t_{INVH}	Fig.2		80		μs	
	Low	t_{INVL}			30		μs	
RECEIVER INPUTS								
Input Voltage Range		V_{RR}		-25		25	V	
Input Threshold Low		V_{RINL}	$T_A = 25^\circ C$	$V_{CC} = 3.3V$	0.6	1.2	V	
				$V_{CC} = 5.0V$	0.8	1.5		
Input Threshold High		V_{RINH}	$T_A = 25^\circ C$	$V_{CC} = 3.3V$		1.5	2.4	V
				$V_{CC} = 5.0V$		1.8	2.4	
Input Hysteresis		V_{RINHYS}			0.3		V	
Input Resistance		V_{RINRES}	$T_A = 25^\circ C$	3	5	8	k Ω	
TRANSMITTER OUTPUTS								
Output Voltage Swing		V_{TOUTSW}	All transmitter outputs loaded with 3k Ω to ground	± 5.0	± 5.4		V	
Output Resistance		$V_{TOUTRES}$	$V_{CC} = V_+ = V_- = 0V$, Transmitter output = $\pm 2V$	300	10M		Ω	
Output Short-Circuit Current		I_{TSC}			± 35	± 60	mA	
Output Leakage Current		$I_{TOUT(LK)}$	$V_{OUT} = \pm 12V$, Transmitters disabled			± 25	μA	
MOUSE DRIVABILITY								
Transmitter Output Voltage		V_{TOUT}	$T_{1IN} = T_{2IN} = GND$, $T_{3IN} = V_{CC}$, T_{3OUT} loaded with 3k Ω to GND, T_{1OUT} and T_{2OUT} loaded with 2.5mA each	± 5.0			V	
TIMING CHARACTERISTICS								
Maximum Data Rate		DR	$R_L = 3k\Omega$, $C_L = 1000pF$, one transmitter switching	120	235		kbps	
Receiver Propagation Delay		t_{PHL}	Receiver input to receiver output, $C_L = 150pF$		0.3		μs	
		t_{PLH}			0.3			
Receiver Output Time	Enable	$t_{R(EN)}$	Normal operation		200		ns	
	Disable	$t_{R(DIS)}$			200		ns	
Transmitter Skew		t_{TS}	$ t_{PHL} - t_{PLH} $		200	1000	ns	
Receiver Skew		t_{RS}	$ t_{PHL} - t_{PLH} $		100	500	ns	
Transition-Region Slew Rate		SR	$V_{CC} = 3.3V$, $T_A = 25^\circ C$, $R_L = 3k\Omega \sim 7k\Omega$, measured from +3V $\sim -3V$ or $-3V \sim +3V$	$C_L = 200pF \sim 2500pF$	4	13	30	V/ μs
				$C_L = 200pF \sim 1000pF$	6	15	30	

Notes: 1. Typical values are at $V_{CC} = 3.3V$ or $V_{CC} = 5.0V$, and $T_A = 25^\circ C$.

2. $C1 \sim C4 = 0.1\mu F$, measured at $3.0V \sim 3.6V$. $C1 = 0.047\mu F$, $C2 \sim C4 = 0.33\mu F$, measured at $4.5V \sim 5.5V$.

■ DETAILED DESCRIPTION

Charge-Pump Voltage Converter

The UTC **UT5232** consists of a regulated dual charge pumps that provide output voltages of +5.5V and -5.5V, regardless of the input voltage (V_{CC}) changing from +3.0V to +5.5V.

The charge pumps operate in a discontinuous mode: if the output voltages are less than 5.5V, the charge pumps are enabled; if the output voltages exceed 5.5V, the charge pumps are disabled.

Each charge pump requires a flying capacitor (C1, C2) and a reservoir capacitor (C3, C4) to generate the V+ and V- supplies, refer to application circuit.

RS-232 Transmitters

UTC **UT5232**'s transmitters are inverting level translators that convert CMOS-logic levels to 5.0V EIA/TIA-232 levels. They guarantee a 120kbps data rate with worst-case loads of 3kΩ in parallel with 1000pF, providing compatibility with PC-to-PC communication software. Typically, the UTC **UT5232** can operate at data rates of 235kbps.

Transmitters can be paralleled to drive multiple receivers or mouse. When $\overline{FORCEOFF}$ is driven to ground, or shutdown circuitry senses invalid voltage levels at all receiver inputs, the transmitters are disabled and the outputs are forced into a high-impedance state.

RS-232 Receivers

The UTC **UT5232**'s receivers convert RS-232 signals to CMOS-logic output levels. All receivers have one inverting three-state output. If the receivers are in shutdown, the outputs of receivers are high impedance.

The UTC **UT5232** has an always-active complementary output (R_{2OUTB}). R_{2OUTB} is an extra output that monitors receiver activity while the other receivers are high impedance. This allows Ring Indicator to be monitored without forward biasing other devices connected to the receiver outputs. This is ideal for systems where V_{CC} is set to 0V in shutdown to accommodate peripherals.

Table 1. $\overline{FORCEOFF}$ Control Truth Table

$\overline{FORCEOFF}$	T_OUT	R_OUT	R2OUTB
0	High-Z	High-Z	Active
1	Active (Note 3)	Active (Note 3)	Active

Note: 3. If the part is in shutdown mode ($\overline{FORCEOFF} = V_{CC}$, FORCEON = GND), it is shutdown if no valid RS-232 levels are present on all receiver inputs.

Shutdown Function

A 1μA supply current is achieved with shutdown feature, which operates when FORCEON is low and $\overline{FORCEOFF}$ is high. When the UTC **UT5232** senses no valid signal levels on all receiver inputs for 30μs, the on-board power supply and drivers are shut off, reducing supply current to 1μA. This occurs if the RS-232 cable is disconnected or the connected peripheral transmitters are turned off. The system turns on again when a valid level is applied to any RS-232 receiver input. As a result, the system saves power without changes to the existing BIOS or operating system. $\overline{INVALID}$ indicates the receiver inputs' condition, when using shutdown function, the $\overline{INVALID}$ output is high when the device is on and low when the device is shut down.

Table 2. Each Transmitter

INPUT				OUTPUT	DRIVER STATUS
TIN	FORCEON	$\overline{FORCEOFF}$	VALID RIN RS-232 LEVEL	TOUT	
X	X	L	X	Z	Power off
L	H	H	X	H	Normal operation with auto-powerdown disable
H	H	H	X	L	
L	L	H	YES	H	Normal operation with auto-powerdown enabled
H	L	H	YES	L	
X	L	H	NO	Z	Power off with auto-powerdown feature

H=high level, L=low level, X=irrelevant, Z=high impedance, YES=any RIN valid, NO=all RIN invalid.

■ DETAILED DESCRIPTION (Cont.)

Table 3. Each Receiver

INPUT			OUTPUT	RECEIVER STATUS
RIN	FORCEON	$\overline{\text{FORCEOFF}}$	ROUT	
X	X	L	Z	Power off
L	X	H	H	Normal operation
H	X	H	L	
OPEN	X	H	H	

H=high level, L=low level, X=irrelevant, Z=high impedance (off), OPEN=input disconnected or connected driver off.

Table 4. INVALID and R2OUTB Output

VALID RIN RS-232 LEVEL	INPUT			OUTPUT		OUTPUT STATUS
	R2IN	FORCEON	$\overline{\text{FORCEOFF}}$	$\overline{\text{INVALID}}$	R2OUTB	
YES	L	X	X	H	L	Always Active
YES	H	X	X	H	H	
YES	OPEN	X	X	H	L	Always Active
NO	OPEN	X	X	L	L	

H=high level, L=low level, X=irrelevant, Z=high impedance (off),

OPEN=input disconnected or connected driver off, YES=any RIN valid, NO=all RIN invalid.

Table 2 summarizes the UTC **UT5232** operating modes. FORCEON and $\overline{\text{FORCEOFF}}$ override the automatic circuitry and force the transceiver into its normal operating state or into its low-power standby state. When neither control is asserted, the IC selects between these states automatically based on receiver input levels.

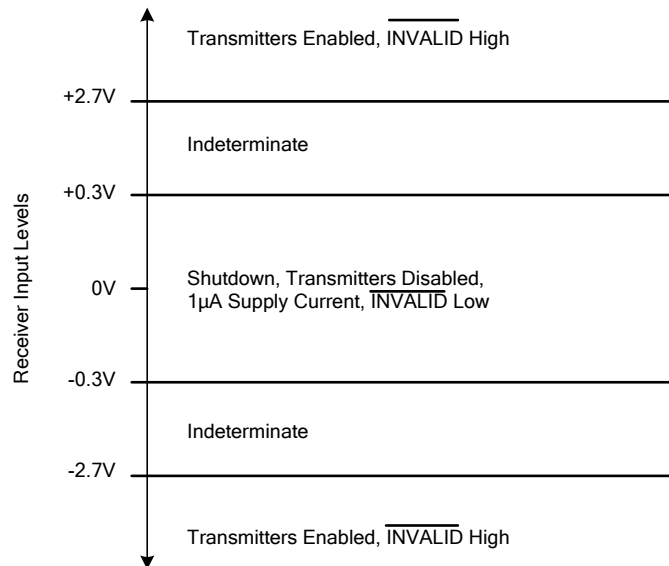

Fig.1 Shutdown Input Levels

■ DETAILED DESCRIPTION (Cont.)

When shutdown, the UTC **UT5232**'s charge pumps are turned off, V+ decays to V_{CC}, V- decays to ground, the transmitter outputs are disabled (high impedance). The time required to exit shutdown is typically 100μs.

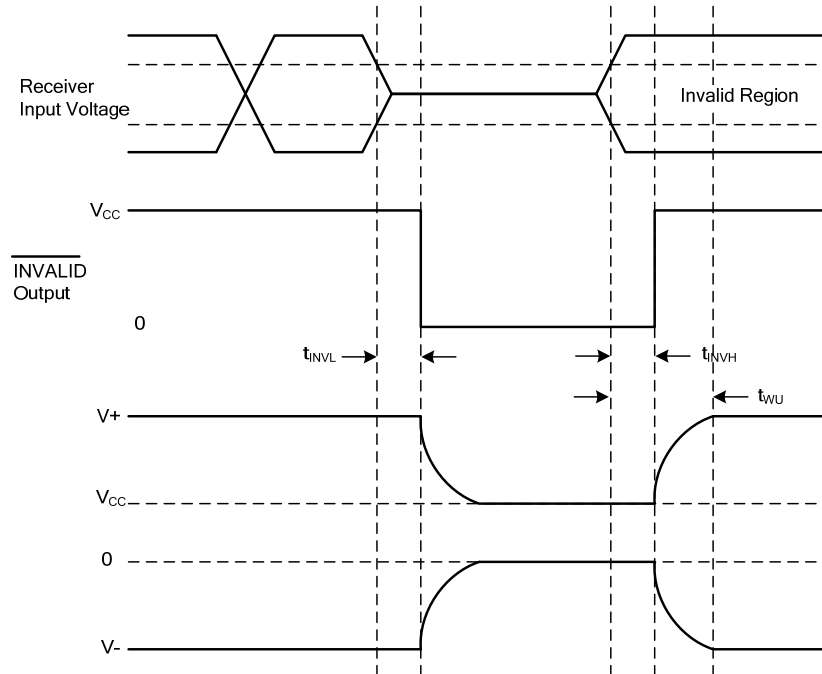

Fig.2 Shutdown Input Timing

■ TYPICAL APPLICATION CIRCUIT

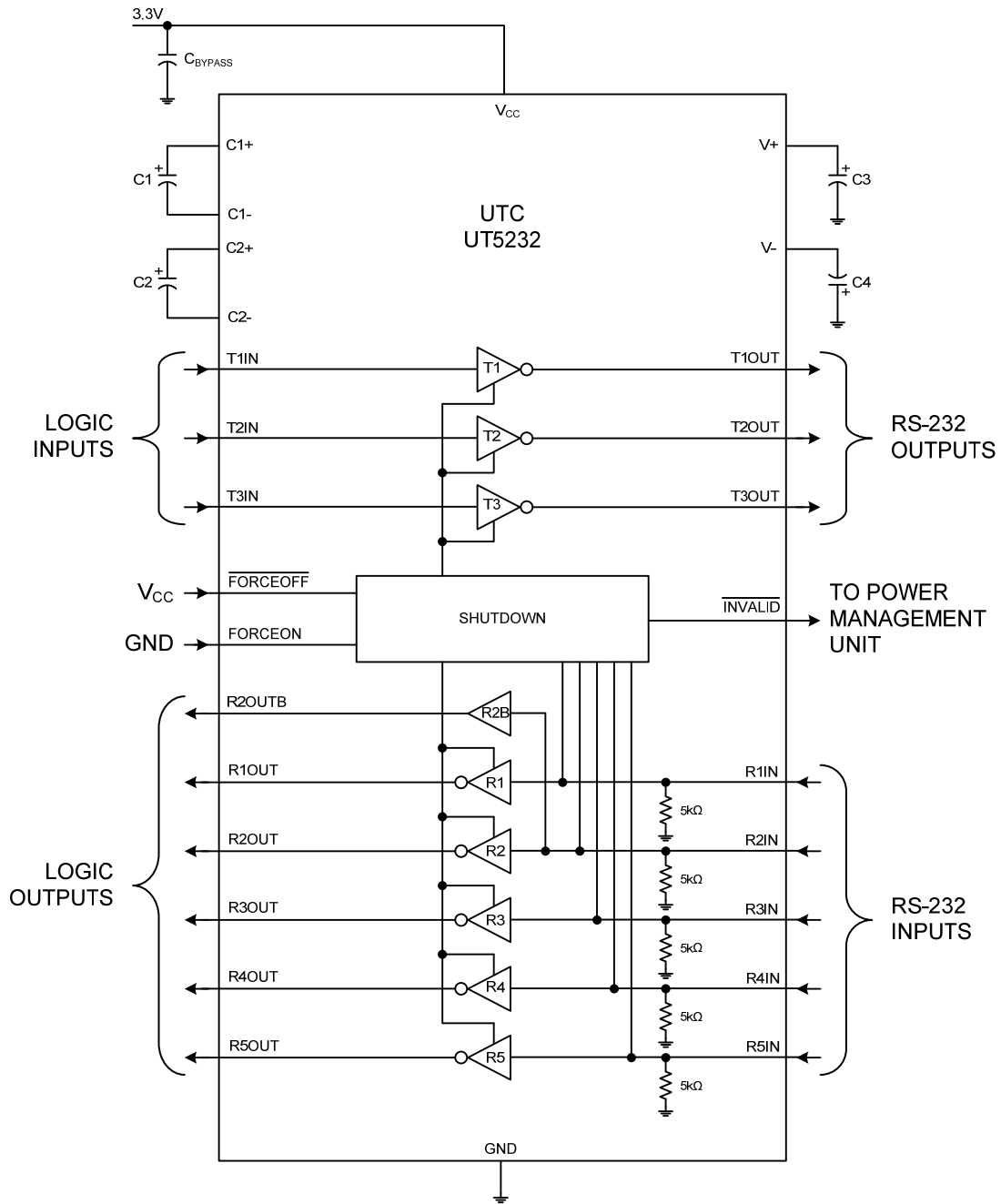

Fig.3 Application Circuit

Table 5. Required Capacitor Value

V _{CC} (V)	C1 (μF)	C2, C3, C4 (μF)	C _{BYPASS} (μF)
3.0 ~ 3.6	0.1	0.1	0.22
4.5 ~ 5.5	0.047	0.33	0.1
3.0 ~ 5.5	0.1	0.47	0.22

■ TYPICAL CHARACTERISTICS

Charge-Pump (C1~C4=0.1μF)

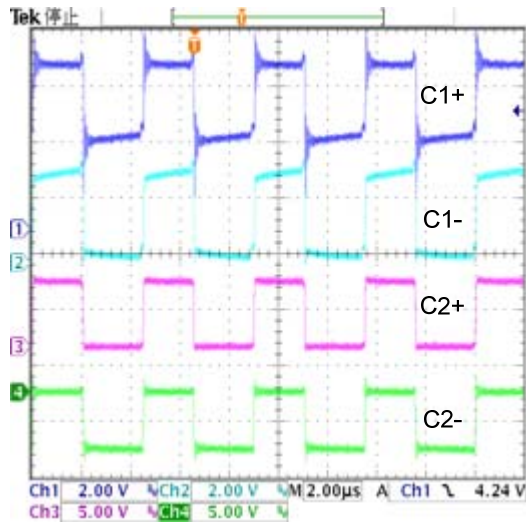

V_{CC}=3V, OUT=3KΩ

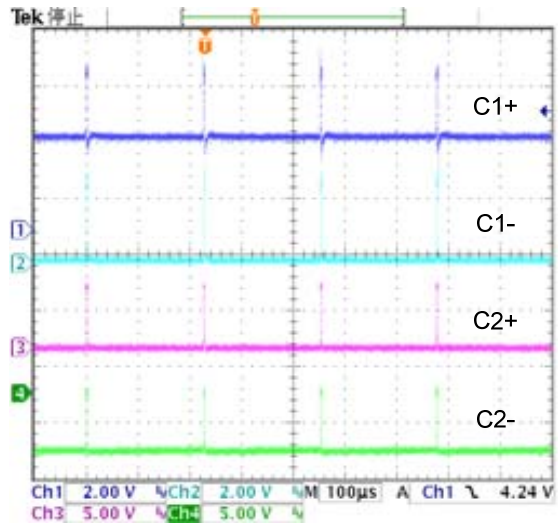

V_{CC}=3V, No Load

UTC assumes no responsibility for equipment failures that result from using products at values that exceed, even momentarily, rated values (such as maximum ratings, operating condition ranges, or other parameters) listed in products specifications of any and all UTC products described or contained herein. UTC products are not designed for use in life support appliances, devices or systems where malfunction of these products can be reasonably expected to result in personal injury. Reproduction in whole or in part is prohibited without the prior written consent of the copyright owner. UTC reserves the right to make changes to information published in this document, including without limitation specifications and product descriptions, at any time and without notice. This document supersedes and replaces all information supplied prior to the publication hereof.