



UD05209

Preliminary

CMOS IC

1.5MHz, 2A, $V_{FB}=0.6V$ SYNCHRONOUS STEP-DOWN CONVERTER

DESCRIPTION

UTC **UD05209** devices are synchronous step-down converters optimized for small solution size and high efficiency. The devices integrate switches capable of delivering an output current up to 2A. The devices are based on an adaptive on time with valley current mode control scheme. Typical operating frequency is 1.5 MHz at medium to heavy loads. The devices are optimized to achieve very low output voltage ripple even with small external components and feature an excellent load transient response. In shutdown, the current consumption is reduced to 1 μ A. The **UD05209** provide an adjustable output voltage via an external resistor divider. The output voltage start-up ramp is controlled by an internal soft start, typically 250 μ s. Power sequencing is possible by configuring the Enable pin. Other features like over current protection and over temperature protection are built in.

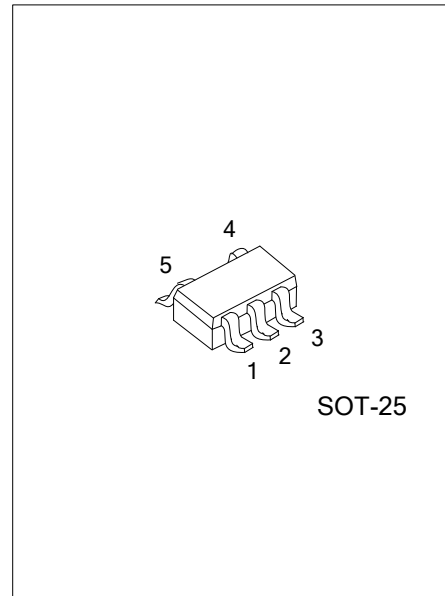

FEATURES

- * 2.7V to 5.5V Input Voltage Range
- * 1.5MHz Typical Switching Frequency
- * Output Current up to 2A
- * Adaptive On-Time Current Control
- * Over Current Protection
- * Internal Soft Startup of 250 μ s (Typ.)
- * Adjustable Output Voltage
- * Thermal Shutdown Protection

ORDERING INFORMATION

Ordering Number		Package	Packing
Lead Free	Halogen Free		
UD05209L-AF5-R	UD05209G-AF5-R	SOT-25	Tape Reel

<p>UD05209G-AF5-R</p> <ul style="list-style-type: none"> (1) Packing Type (2) Package Type (3) Green Package 	<ul style="list-style-type: none"> (1) R: Tape Reel (2) AF5: SOT-25 (3) G: Halogen Free and Lead Free, L: Lead Free
---	--

MARKING

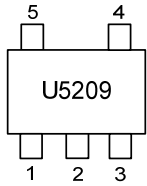

PIN CONFIGURATION

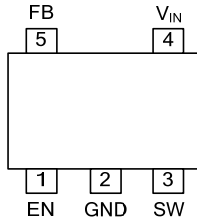

PIN DESCRIPTION

PIN NO.	PIN NAME	DESCRIPTION
1	EN	Enable pin H: Normal operation : L: Shutdown
2	GND	Ground pin
3	SW	Switch pin connected to the internal MOSFET switches and inductor terminal. Connect the inductor of the output filter to this pin.
4	V _{IN}	Power Supply Input Pin
5	FB	Feedback pin for the internal control loop. Connect this pin to the external feedback divider.

BLOCK DIAGRAM

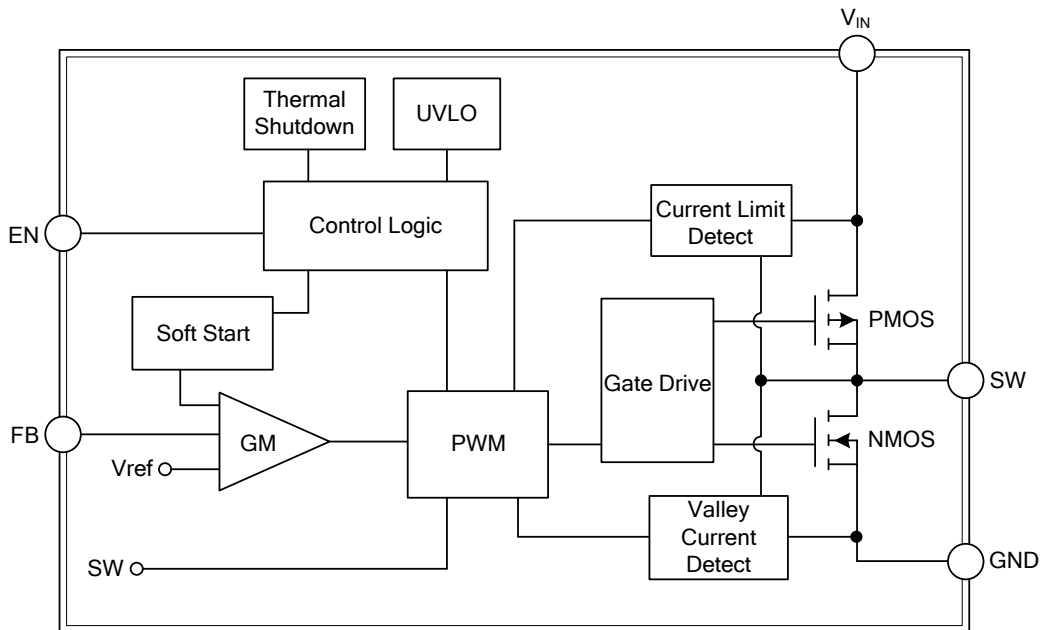

■ ABSOLUTE MAXIMUM RATING ($T_A=25^\circ\text{C}$, unless otherwise specified)

PARAMETER	SYMBOL	RATINGS	UNIT
IN Pin Voltage	V_{IN}	7	V
Enable Pin Voltage	V_{EN}	7	V
Switch Pin Voltage	V_{SW}	V_{IN}	V
Feedback Pin Voltage	V_{FB}	3.6	V
Junction Temperature	T_J	0 ~ +150	$^\circ\text{C}$
Operating Temperature	T_{OPR}	0 ~ +150	$^\circ\text{C}$
Storage Temperature	T_{STG}	0 ~ +150	$^\circ\text{C}$

Note: Absolute maximum ratings are those values beyond which the device could be permanently damaged. Absolute maximum ratings are stress ratings only and functional device operation is not implied.

■ THERMAL DATA

PARAMETER	SYMBOL	RATINGS	UNIT
Junction to Ambient	θ_{JA}	280	$^\circ\text{C/W}$

■ ELECTRICAL CHARACTERISTICS ($V_{IN}=V_{EN}=3.6\text{V}$, $T_A=25^\circ\text{C}$, unless otherwise specified)

PARAMETER	SYMBOL	TEST CONDITIONS	MIN	TYP	MAX	UNIT
Input Voltage Range	V_{IN}		2.7		5.5	V
Quiescent Current Into V_{IN} Pin	I_Q	$I_{OUT} = 0\text{mA}$, Not switching		700		μA
Under Voltage Lock Out	V_{UVLO}			2.2		V
High-Level Input Voltage	V_{IH}	$2.7\text{ V} \leq V_{IN} \leq 5.5\text{ V}$		0.85		V
Low-Level Input Voltage	V_{IL}	$2.7\text{ V} \leq V_{IN} \leq 5.5\text{ V}$		0.8		V
Shutdown Current Into V_{IN} Pin	I_{SD}			1		μA
EN Leakage Current	$I_{EN, LKG}$			1		μA
Feedback Regulation Voltage	V_{FB}		0.588	0.6	0.612	V
High-Side FET on Resistance	$R_{DS(ON)}$	$I_{SW} = 1000\text{mA}$, $V_{IN} = 3.6\text{V}$		120		$\text{m}\Omega$
Low-Side FET on Resistance		$I_{SW} = 1000\text{mA}$, $V_{IN} = 3.6\text{V}$		105		$\text{m}\Omega$
Low-Side FET Valley Current Limit	$I_{LIM, LS}$			1.3		A
High-Side FET Peak Current Limit	$I_{LIM, HS}$			3.8		A
Switching Frequency	f_{SW}	$I_{LOAD}=1\text{A}$		1.5		MHz
Minimum off Time	$t_{OFF MIN}$			90		ns

■ TYPICAL APPLICATION CIRCUIT

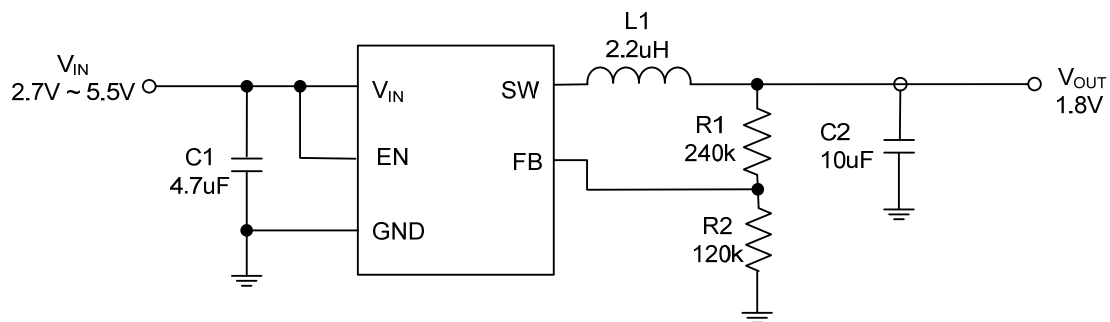

■ FUNCTION DESCRIPTIONS

UD05209 operates with an adaptive on-time control scheme, which is able to dynamically adjust the on-time duration based on the input voltage and output voltage so that it can achieve relative constant frequency operation. The device operates at typically 1.5-MHz frequency pulse width modulation (PWM) at moderate to heavy load currents.

SOFT START

After enabling the device, internal soft-start circuitry monotonically ramps up the output voltage which reaches nominal output voltage during a soft-start time of 250 μ s (typical). This avoids excessive inrush current and creates a smooth output voltage rise slope.

SHORT CIRCUIT PROTECTION

To avoid mis-operation of the device, short circuit protection is implemented that latch output to GND when output short.

UTC assumes no responsibility for equipment failures that result from using products at values that exceed, even momentarily, rated values (such as maximum ratings, operating condition ranges, or other parameters) listed in products specifications of any and all UTC products described or contained herein. UTC products are not designed for use in life support appliances, devices or systems where malfunction of these products can be reasonably expected to result in personal injury. Reproduction in whole or in part is prohibited without the prior written consent of the copyright owner. UTC reserves the right to make changes to information published in this document, including without limitation specifications and product descriptions, at any time and without notice. This document supersedes and replaces all information supplied prior to the publication hereof.