



## 12N50-TC

Power MOSFET

### 12A, 500V N-CHANNEL POWER MOSFET

#### DESCRIPTION

The UTC 12N50-TC is a high voltage and high current power MOSFET, designed to have better characteristics, such as fast switching time, low gate charge, low on-state resistance and a high rugged avalanche characteristics. This power MOSFET is usually used at high speed switching applications in power supplies, PWM motor controls, high efficient DC to DC converters and bridge circuits.

#### FEATURES

- \*  $R_{DS(ON)} \leq 0.65 \Omega @ V_{GS}=10V, I_D=6.0A$
- \* Fast switching
- \* Improved dv/dt capability

#### SYMBOL

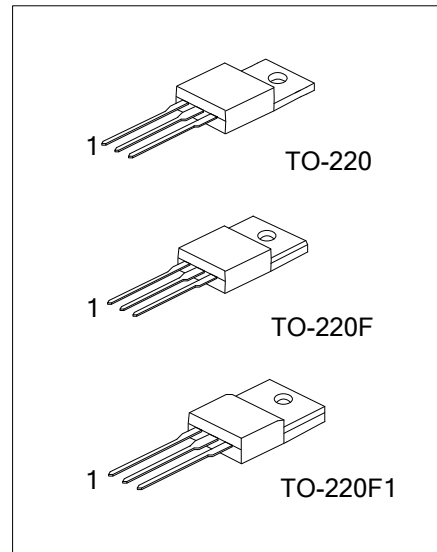
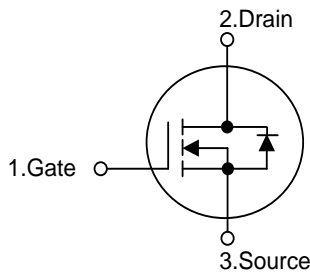

#### ORDERING INFORMATION

Ordering Number		Package	Pin Assignment			Packing
Lead Free	Halogen Free		1	2	3	
12N50L-TA3-T	12N50G-TA3-T	TO-220	G	D	S	Tube
12N50L-TF1-T	12N50G-TF1-T	TO-220F1	G	D	S	Tube
12N50L-TF3-T	12N50G-TF3-T	TO-220F	G	D	S	Tube

Note: Pin Assignment: G: Gate C: Collector E: Emitter

<p>12N50G-TA3-T</p> <p>(1) Packing Type</p> <p>(2) Package Type</p> <p>(3) Green Package</p>	<p>(1) T: Tube</p> <p>(2) TA3: TO-220, TF1: TO-220F1, TF3: TO-220F</p> <p>(3) G: Halogen Free and Lead Free, L: Lead Free</p>
--	---

#### MARKING

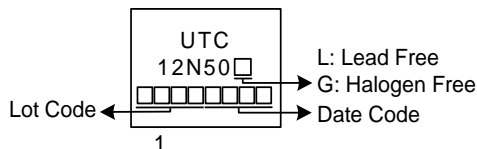

### ■ ABSOLUTE MAXIMUM RATINGS (T<sub>C</sub> = 25°C, unless otherwise specified)

PARAMETER		SYMBOL	RATINGS	UNIT
Drain-Source Voltage		V <sub>DSS</sub>	500	V
Gate-Source Voltage		V <sub>GSS</sub>	±30	V
Drain Current	Continuous	I <sub>D</sub>	12	A
	Pulsed (Note 2)	I <sub>DM</sub>	24	A
Avalanche Energy	Single Pulsed (Note 3)	E <sub>AS</sub>	310	mJ
Peak Diode Recovery dv/dt (Note 4)		dv/dt	4.1	V/ns
Power Dissipation	TO-220	P <sub>D</sub>	150	W
	TO-220F/TO-220F1		36	W
Junction Temperature		T <sub>J</sub>	+150	°C
Storage Temperature		T <sub>STG</sub>	-55 ~ +150	°C

Notes: 1. Absolute maximum ratings are those values beyond which the device could be permanently damaged.

Absolute maximum ratings are stress ratings only and functional device operation is not implied.

2. Repetitive Rating : Pulse width limited by maximum junction temperature

3. L = 10mH, I<sub>AS</sub> = 7.85A, V<sub>DD</sub> = 50V, R<sub>G</sub> = 25Ω, Starting T<sub>J</sub> = 25°C

4. I<sub>SD</sub> ≤ 12A, di/dt ≤ 200A/s, V<sub>DD</sub> ≤ BV<sub>DSS</sub> Starting T<sub>J</sub> = 25°C

### ■ THERMAL DATA

PARAMETER		SYMBOL	RATINGS	UNIT
Junction to Ambient		θ <sub>JA</sub>	62.5	°C/W
Junction to Case	TO-220	θ <sub>JC</sub>	0.83	°C/W
	TO-220F/TO-220F1		3.47	°C/W

### ■ ELECTRICAL CHARACTERISTICS (T<sub>C</sub>=25°C, unless otherwise specified)

PARAMETER	SYMBOL	TEST CONDITIONS	MIN	TYP	MAX	UNIT
<b>OFF CHARACTERISTICS</b>						
Drain-Source Breakdown Voltage	BV <sub>DSS</sub>	V <sub>GS</sub> =0V, I <sub>D</sub> =250μA	500			V
Drain-Source Leakage Current	I <sub>DSS</sub>	V <sub>DS</sub> =500V, V <sub>GS</sub> =0V			10	μA
Gate-Source Leakage Current	I <sub>GSS</sub>	V <sub>GS</sub> =±30V, V <sub>DS</sub> =0V			±100	nA
<b>ON CHARACTERISTICS</b>						
Gate Threshold Voltage	V <sub>GS(TH)</sub>	V <sub>DS</sub> =V <sub>GS</sub> , I <sub>D</sub> =250μA	2.0		4.0	V
Static Drain-Source On-State Resistance	R <sub>DS(ON)</sub>	V <sub>GS</sub> =10V, I <sub>D</sub> =6.0A			0.65	Ω
<b>DYNAMIC CHARACTERISTICS</b>						
Input Capacitance	C <sub>ISS</sub>	V <sub>DS</sub> =25V, V <sub>GS</sub> =0V, f=1MHz		1380		pF
Output Capacitance	C <sub>OSS</sub>			140		pF
Reverse Transfer Capacitance	C <sub>RSS</sub>			5		pF
<b>SWITCHING CHARACTERISTICS</b>						
Total Gate Charge	Q <sub>G</sub>	V <sub>DS</sub> =100V, V <sub>GS</sub> =10V, I <sub>D</sub> =12A, I <sub>G</sub> =1mA (Note1,2)		26		nC
Gate-Source Charge	Q <sub>GS</sub>			11		nC
Gate-Drain Charge	Q <sub>GD</sub>			6		nC
Turn-On Delay Time	t <sub>D(ON)</sub>	V <sub>DD</sub> =100V, I <sub>D</sub> =12A, R <sub>G</sub> =25Ω (Note1,2)		21		ns
Turn-On Rise Time	t <sub>R</sub>			19		ns
Turn-Off Delay Time	t <sub>D(OFF)</sub>			80		ns
Turn-Off Fall Time	t <sub>F</sub>			23		ns
<b>SOURCE- DRAIN DIODE RATINGS AND CHARACTERISTICS</b>						
Maximum Body-Diode Continuous Current	I <sub>S</sub>				12	A
Maximum Body-Diode Pulsed Current	I <sub>SM</sub>				24	A
Drain-Source Diode Forward Voltage	V <sub>SD</sub>	V <sub>GS</sub> =0V, I <sub>S</sub> =12A			1.4	V
Reverse Recovery Time	t <sub>rr</sub>	V <sub>GS</sub> =0V, I <sub>S</sub> =12A, di/dt=100A/μs		324		ns
Reverse Recovery Charge	Q <sub>rr</sub>			3.9		μC

Notes: 1. Pulse Test : Pulse width ≤ 300μs, Duty cycle ≤ 2%.

2. Essentially independent of operating temperature.

## ■ TEST CIRCUITS AND WAVEFORMS

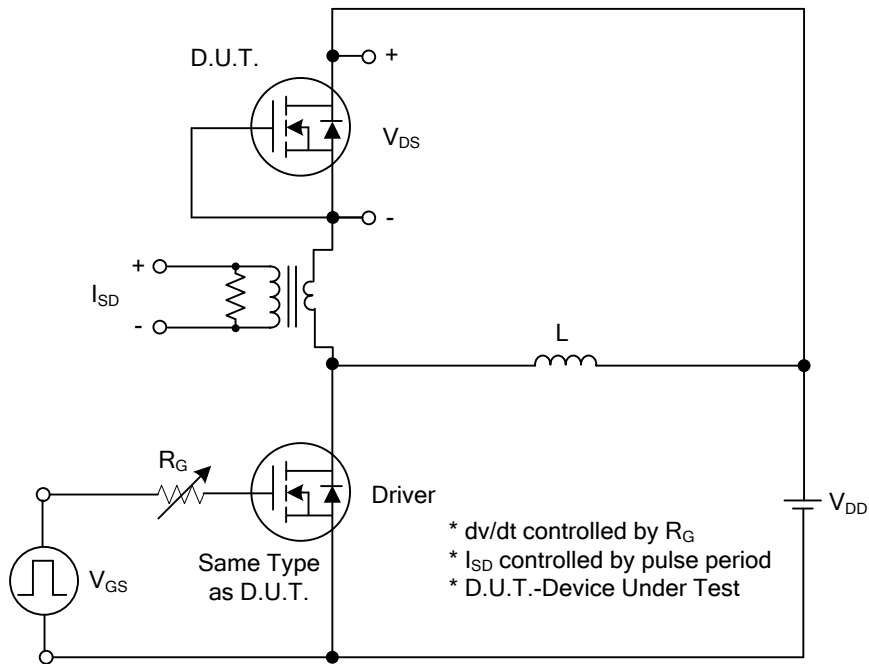

Peak Diode Recovery  $dv/dt$  Test Circuit

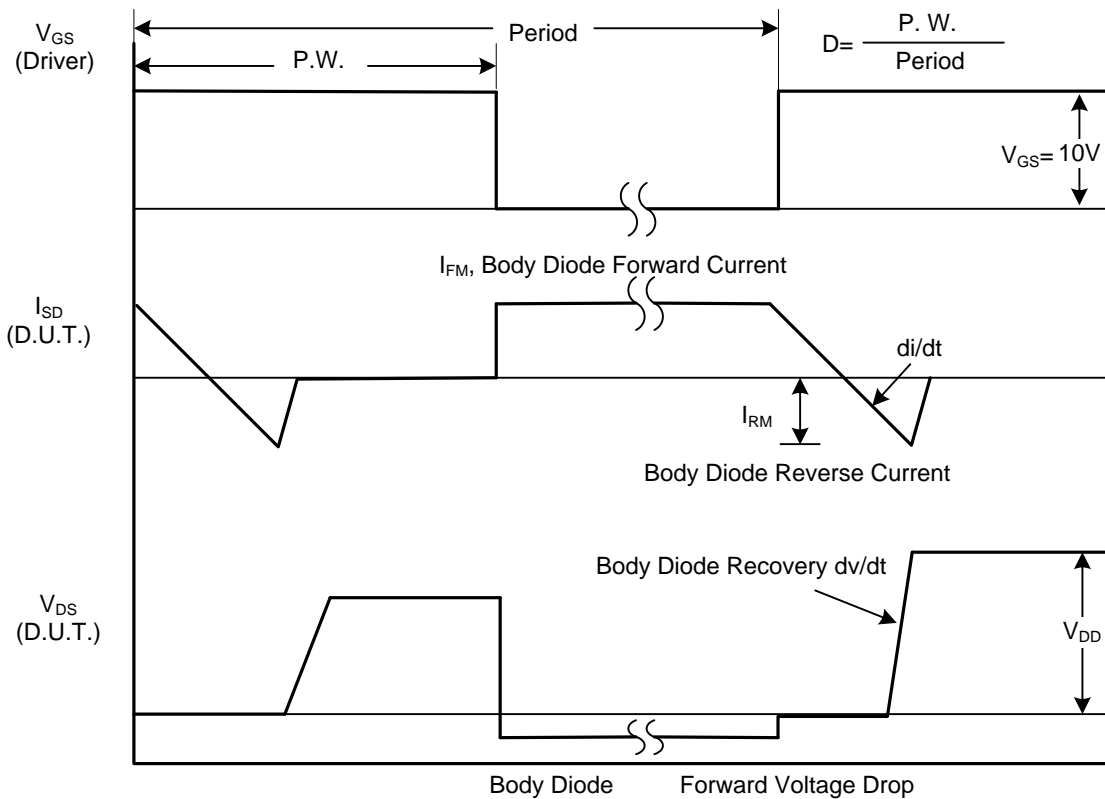

Peak Diode Recovery  $dv/dt$  Waveforms

## TEST CIRCUITS AND WAVEFORMS

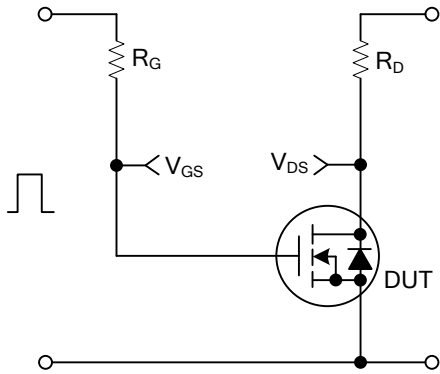

Switching Test Circuit

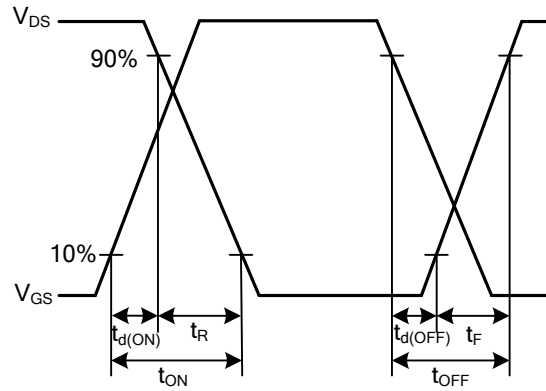

Switching Waveforms

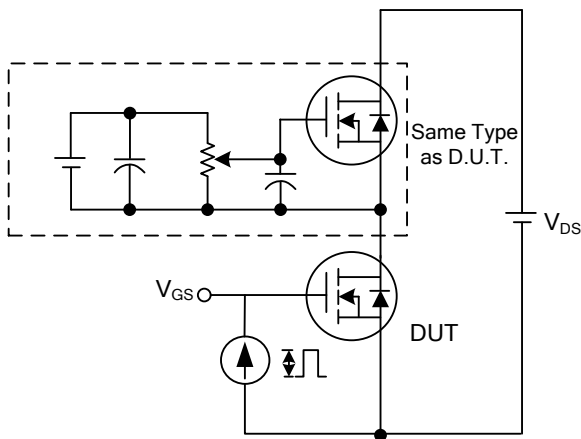

Gate Charge Test Circuit

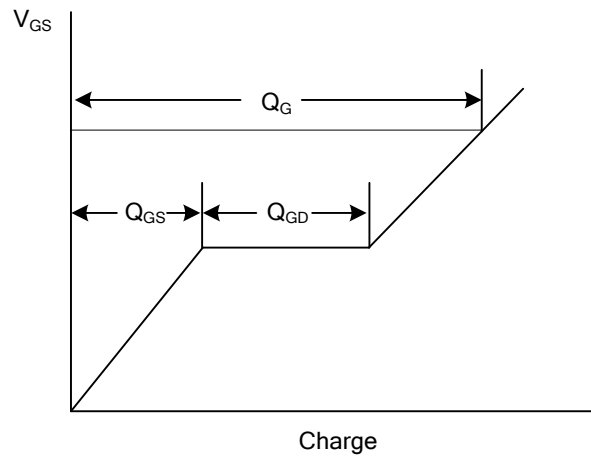

Gate Charge Waveform

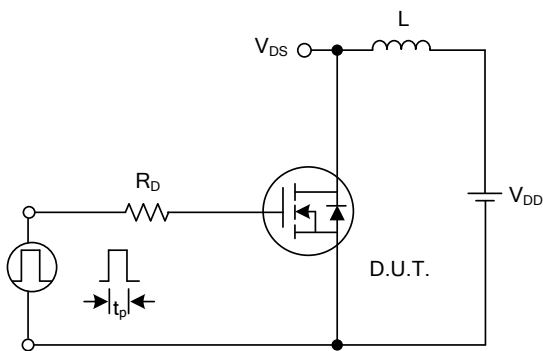

Unclamped Inductive Switching Test Circuit

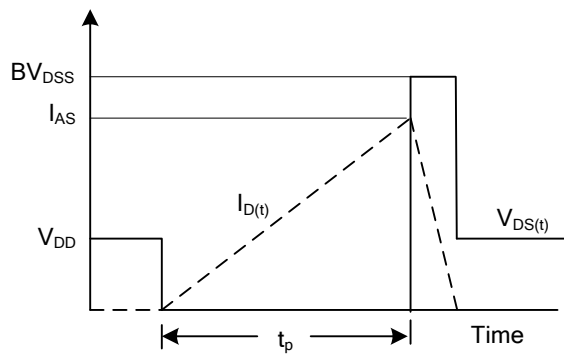

Unclamped Inductive Switching Waveforms

## ■ TYPICAL CHARACTERISTICS

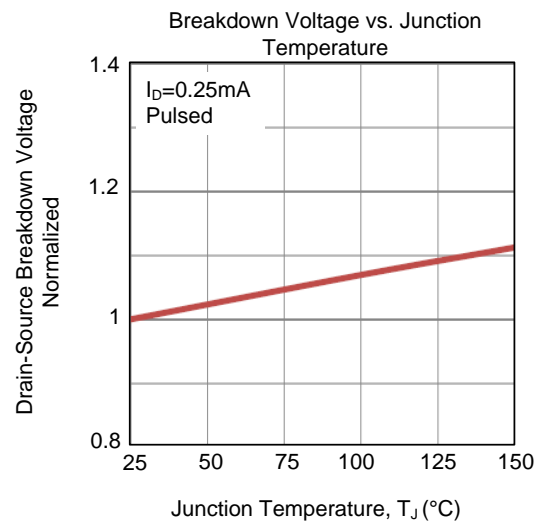
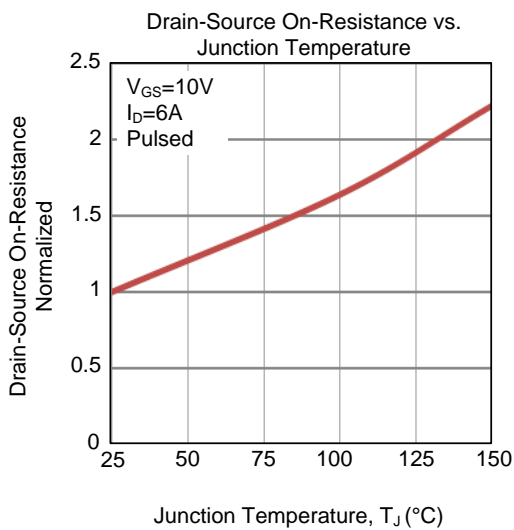
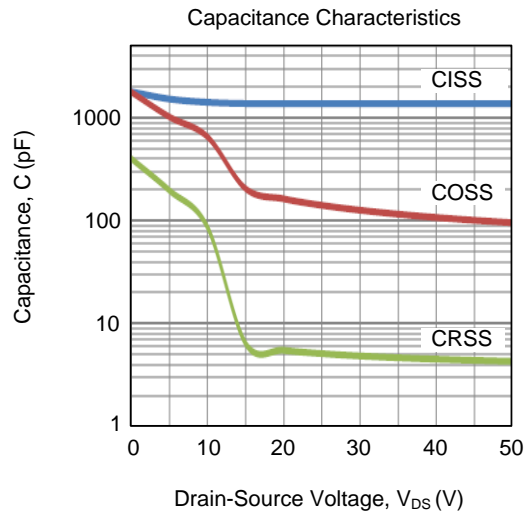
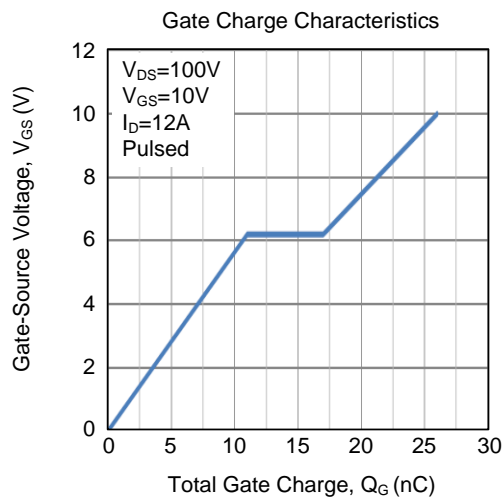
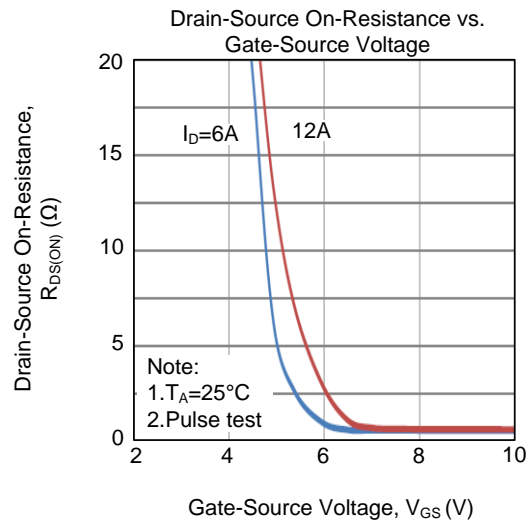
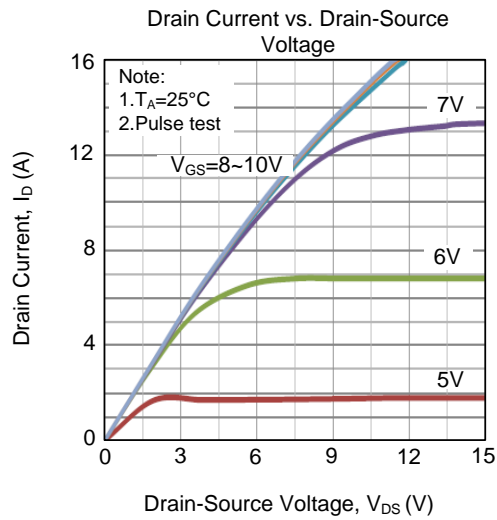

## ■ TYPICAL CHARACTERISTICS (Cont.)

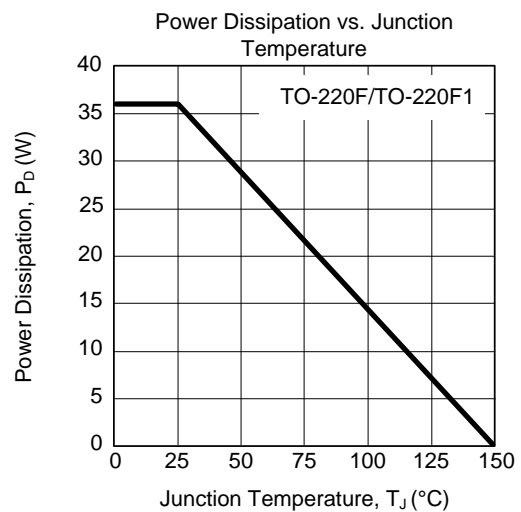
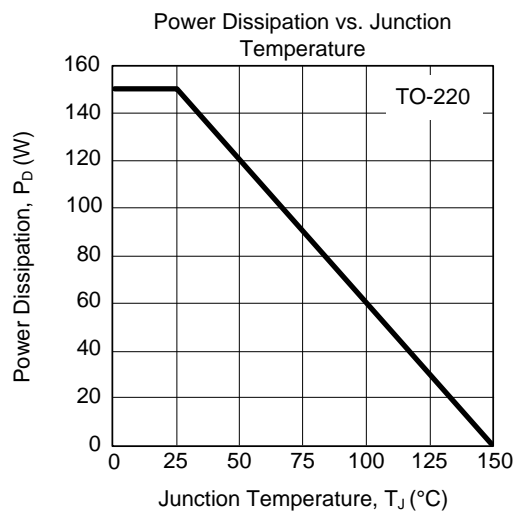
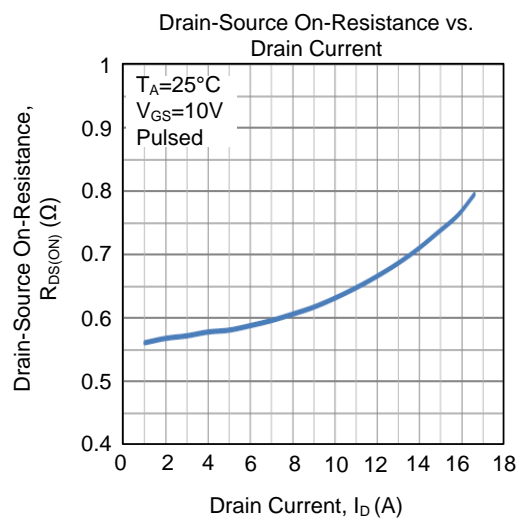
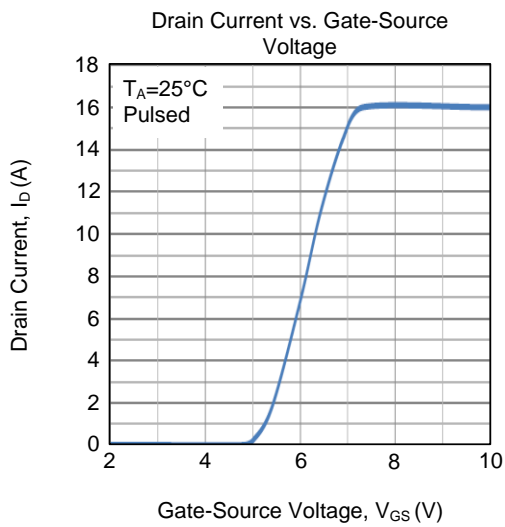
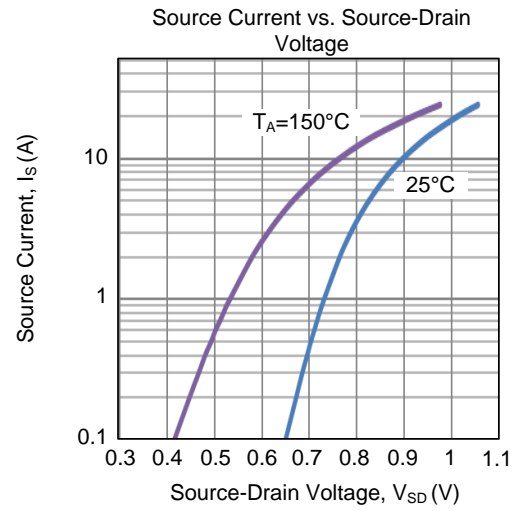
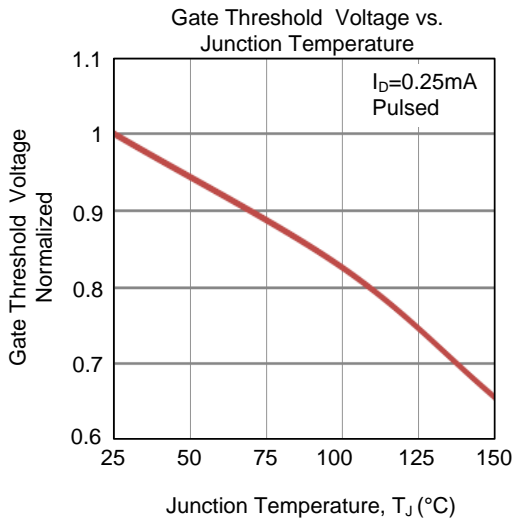

### ■ TYPICAL CHARACTERISTICS (Cont.)

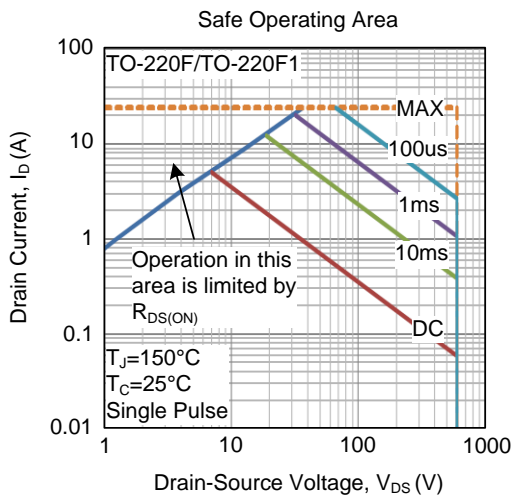
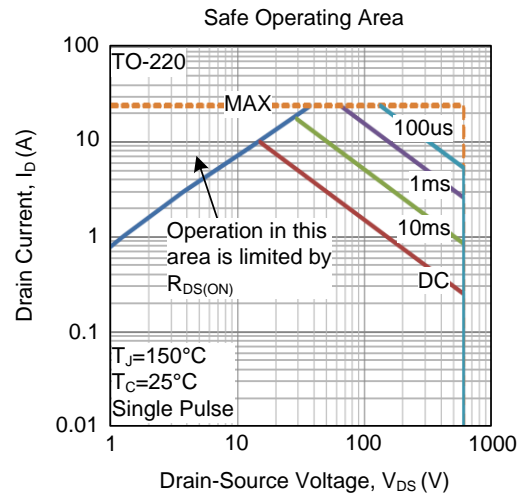
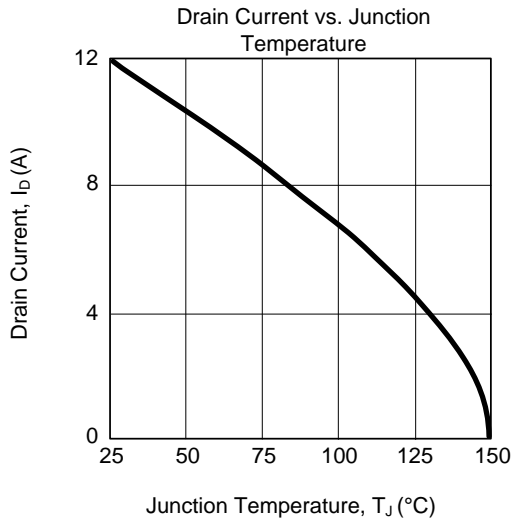

UTC assumes no responsibility for equipment failures that result from using products at values that exceed, even momentarily, rated values (such as maximum ratings, operating condition ranges, or other parameters) listed in products specifications of any and all UTC products described or contained herein. UTC products are not designed for use in life support appliances, devices or systems where malfunction of these products can be reasonably expected to result in personal injury. Reproduction in whole or in part is prohibited without the prior written consent of the copyright owner. UTC reserves the right to make changes to information published in this document, including without limitation specifications and product descriptions, at any time and without notice. This document supersedes and replaces all information supplied prior to the publication hereof.