



U74HC273

CMOS IC

OCTAL D-TYPE FLIP-FLOPS WITH CLEAR

DESCRIPTION

The **U74HC273** devices are positive-edge-triggered D-type flip-flops with a direct active low clear (CLR) input.

Information at the data (D) inputs meeting the setup time requirements is transferred to the Q outputs on the positive-going edge of the clock (CLK) pulse. Clock triggering occurs at a particular voltage level and is not related directly to the transition time of the positive-going pulse. When CLK is at either the high or low level, the D input has no effect at the output.

FEATURES

- * Wide Operating Voltage Range of 2V to 6V
- * Low Power Consumption, 80- μ A Maximum I_{CC}
- * Typical $t_{PD} = 12ns$
- * $\pm 4mA$ Output Drive at 5V
- * Low Input Current of 1 μ A Maximum
- * Contain Eight Flip-Flops With Single-Rail Outputs
- * Direct Clear Input
- * Individual Data Input to Each Flip-Flop

ORDERING INFORMATION

Ordering Number		Package	Packing
Lead Free	Halogen Free		
U74HC273L-D20-T	U74HC273G-D20-T	DIP-20	Tube
U74HC273L-S20-R	U74HC273G-S20-R	SOP-20	Tape Reel
U74HC273L-R20-R	U74HC273G-R20-R	SSOP-20	Tape Reel
U74HC273L-P20-R	U74HC273G-P20-R	TSSOP-20	Tape Reel

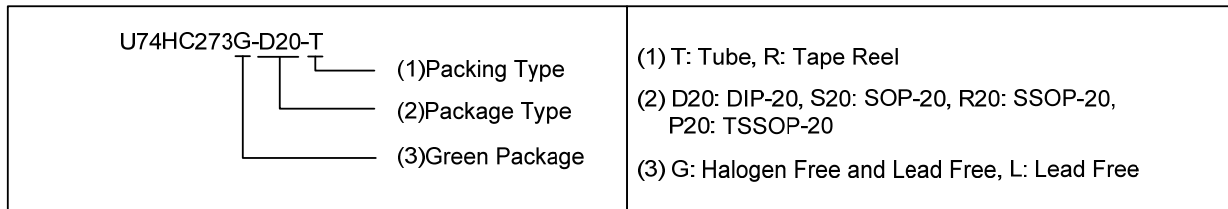

MARKING

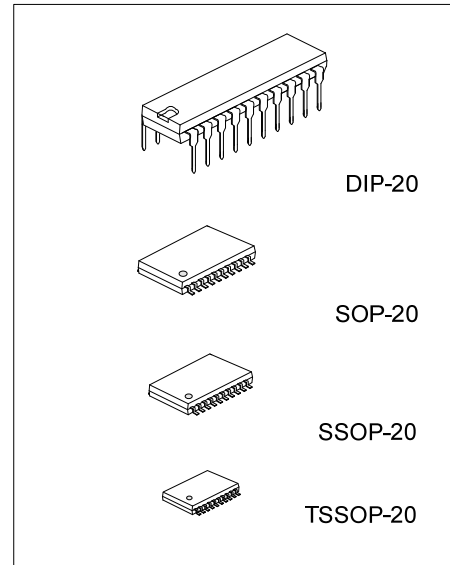
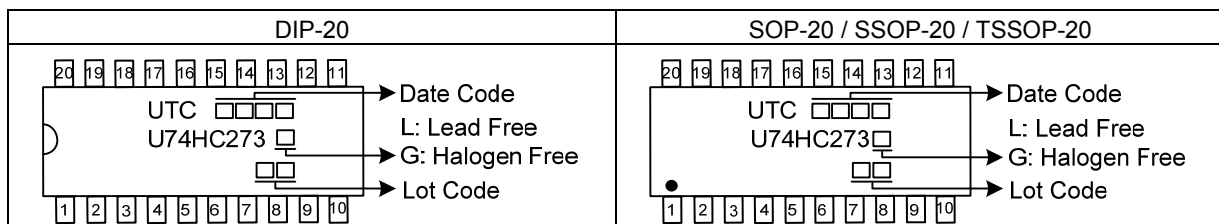

■ PIN CONFIGURATION

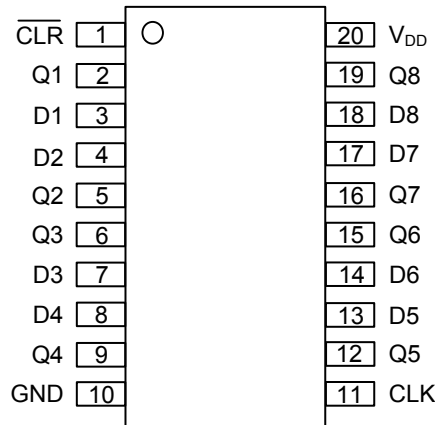

■ FUNCTION TABLE

INPUTS			OUTPUT
$\overline{\text{CLR}}$	CLK	D	Q
L	X	X	L
H	\uparrow	H	H
H	\uparrow	L	L
H	L	X	Q_0

H = High voltage level ; L = Low voltage level ; X = Don't care

■ FUNCTIONAL BLOCK DIAGRAM

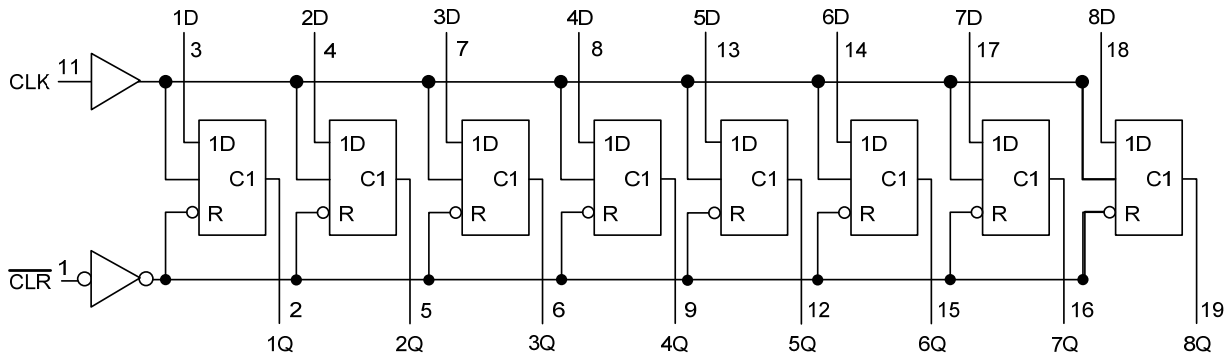

■ LOGIC DIAGRAM, EACH FLIP-FLOP (POSITIVE LOGIC)

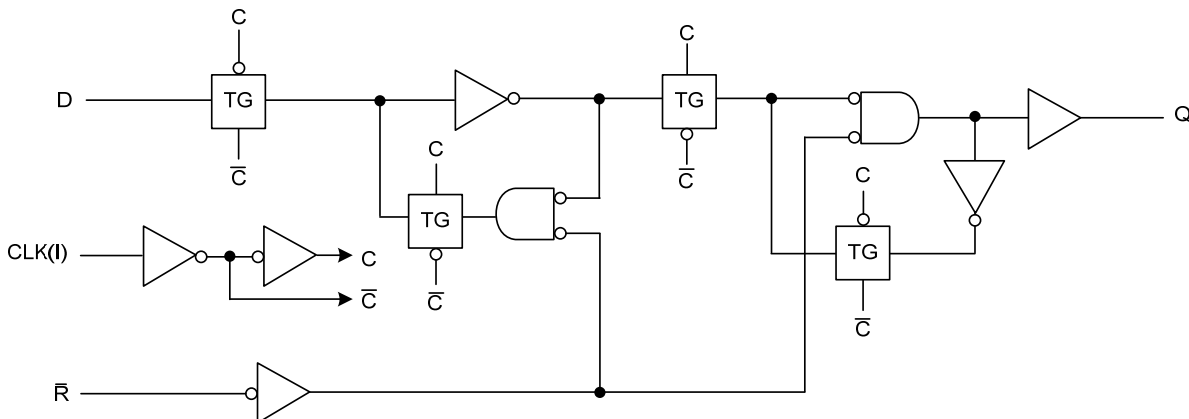

■ ABSOLUTE MAXIMUM RATING (T_A=25°C, unless otherwise specified)

PARAMETER	SYMBOL	CONDITIONS	RATINGS	UNIT
Supply Voltage	V _{CC}		-0.5 ~ 7.0	V
V _{CC} or GND Current	I _{CC}		±50	mA
Continuous Output Current	I _{OUT}	V _{OUT} =0 ~ V _{CC}	±25	mA
Input Clamp Current	I _{IK}	V _{IN} <0 or V _{IN} <V _{CC}	±20	mA
Output Clamp Current	I _{OK}	V _{IN} <0 or V _{OUT} >V _{CC}	±20	mA
Storage Temperature Range	T _{STG}		-65 ~ +150	°C

Note: Absolute maximum ratings are those values beyond which the device could be permanently damaged. Absolute maximum ratings are stress ratings only and functional device operation is not implied.

■ RECOMMENDED OPERATING COMDITIONS

PARAMETER	SYMBOL	CONDITIONS	MIN	TYP	MAX	UNIT
Supply Voltage	V _{CC}		2	5	6	V
High-Level Input Voltage	V _{IH}	V _{CC} =2V	1.5			V
		V _{CC} =4.5V	3.15			V
		V _{CC} =6V	4.2			V
Low-Level Input Voltage	V _{IL}	V _{CC} =2V			0.5	V
		V _{CC} =4.5V			1.35	V
		V _{CC} =6V			1.8	V
Input Voltage	V _{IN}		0		V _{CC}	V
Output Voltage	V _{OUT}		0		V _{CC}	V
Input Transition Rise or Fall Rate	t _R , t _F	V _{CC} =2V			1000	ns
		V _{CC} =4.5V			500	ns
		V _{CC} =6V			400	ns
Operating Temperature	T _A		-40		+125	°C

■ ELECTRICAL CHARACTERISTICS (Unless otherwise specified)

PARAMETER	SYMBOL	TEST CONDITIONS	T _A =25°C			T _A =-40~+125°C			UNIT
			MIN	TYP	MAX	MIN	TYP	MAX	
High-Level Output Voltage	V _{OH}	V _{CC} =2V, I _{OH} =-20μA	1.9	1.998		1.9			V
		V _{CC} =4.5V, I _{OH} =-20μA	4.4	4.499		4.4			V
		V _{CC} =6V, I _{OH} =-20μA	5.9	5.999		5.9			V
		V _{CC} =4.5V, I _{OH} =-4mA	3.98	4.3		3.7			V
		V _{CC} =6V, I _{OH} =-5.2mA	5.48	5.8		5.2			V
Low-Level Output Voltage	V _{OL}	V _{CC} =2V, I _{OL} =20μA		0.002	0.1			0.1	V
		V _{CC} =4.5V, I _{OL} =20μA		0.001	0.1			0.1	V
		V _{CC} =6V, I _{OL} =20μA		0.001	0.1			0.1	V
		V _{CC} =4.5V, I _{OL} =4mA		0.17	0.26			0.4	V
		V _{CC} =6V, I _{OL} =5.2mA		0.15	0.26			0.4	V
Input Leakage Current	I _{I(LEAK)}	V _{CC} =6V, V _I =V _{CC} or 0		±0.1	±100			±100	μA
Quiescent Supply Current	I _{CC}	V _{CC} =6V, V _I =V _{CC} or 0, I _{OUT} =0			8			160	μA

■ SWITCHING CHARACTERISTICS ($C_L=50\text{pF}$, unless otherwise specified)

PARAMETER	SYMBOL	TEST CONDITIONS	$T_A=25^\circ\text{C}$			$T_A=-40\sim+125^\circ\text{C}$			UNIT
			MIN	TYP	MAX	MIN	TYP	MAX	
Maximum clock pulse frequency	f_{MAX}	$V_{\text{CC}}=2.0\text{V}$	5	11		4			MHz
		$V_{\text{CC}}=4.5\text{V}$	27	50		20			MHz
		$V_{\text{CC}}=6.0\text{V}$	32	60		24			MHz
Propagation delay from input ($\overline{\text{CLR}}$) to output (Any)	t_{PHL}	$V_{\text{CC}}=2.0\text{V}$		55	160			225	ns
		$V_{\text{CC}}=4.5\text{V}$		15	32			45	ns
		$V_{\text{CC}}=6.0\text{V}$		12	27			38	ns
Propagation delay from input (CLK) to output (Any)	t_{PD}	$V_{\text{CC}}=2.0\text{V}$		56	160			225	ns
		$V_{\text{CC}}=4.5\text{V}$		15	32			45	ns
		$V_{\text{CC}}=6.0\text{V}$		13	27			38	ns
Propagation delay to output (Any)	t_t	$V_{\text{CC}}=2.0\text{V}$		38	75			110	ns
		$V_{\text{CC}}=4.5\text{V}$		8	15			22	ns
		$V_{\text{CC}}=6.0\text{V}$		6	13			19	ns

■ TIMING REQUIREMENTS (Input: $t_R, t_F \leq 2.5\text{ns}$; $\text{PRR} \leq 1\text{MHz}$)

PARAMETER		SYMBOL	Conditions	$T_A=25^\circ\text{C}$			$T_A=-40\sim+125^\circ\text{C}$			UNIT
				MIN	TYP	MAX	MIN	TYP	MAX	
Clock frequency		f_{CLOCK}	$V_{\text{CC}}=2\text{V}$			5			4	MHz
			$V_{\text{CC}}=4.5\text{V}$			27			20	MHz
			$V_{\text{CC}}=6\text{V}$			32			24	MHz
Pulse duration	CLK high or low	t_w	$V_{\text{CC}}=2\text{V}$		80		120			ns
			$V_{\text{CC}}=4.5\text{V}$		16		24			ns
			$V_{\text{CC}}=6\text{V}$		14		20			ns
	$\overline{\text{CLR}}$ low		$V_{\text{CC}}=2\text{V}$		80		120			ns
			$V_{\text{CC}}=4.5\text{V}$		16		24			ns
			$V_{\text{CC}}=6\text{V}$		14		20			ns
Setup time before CLK \uparrow	Data	t_{SU}	$V_{\text{CC}}=2\text{V}$		100		120			ns
			$V_{\text{CC}}=4.5\text{V}$		20		24			ns
			$V_{\text{CC}}=6\text{V}$		17		20			ns
	$\overline{\text{CLR}}$ inactive		$V_{\text{CC}}=2\text{V}$		100		120			ns
			$V_{\text{CC}}=4.5\text{V}$		20		24			ns
			$V_{\text{CC}}=6\text{V}$		17		20			ns
Hold time ,data after CLK \uparrow		t_H	$V_{\text{CC}}=2\text{V}$		0		-6			ns
			$V_{\text{CC}}=4.5\text{V}$		0		-2			ns
			$V_{\text{CC}}=6\text{V}$		0		-2			ns

■ OPERATING CHARACTERISTICS ($T_A=25^\circ\text{C}$, unless otherwise specified)

PARAMETER	SYMBOL	TEST CONDITIONS	MIN	TYP	MAX	UNIT
Input Capacitance	C_I	$V_{\text{CC}}=2\text{V}\sim 6\text{V}$		3	10	pF
Power Dissipation Capacitance per flip-flop	C_{PD}	No load.		35		pF

■ TEST CIRCUIT AND WAVEFORMS

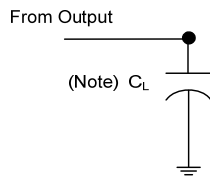

Load Circuit

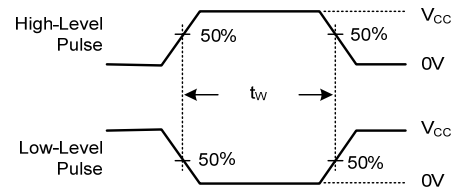

Voltage Waveforms Pulse Durations

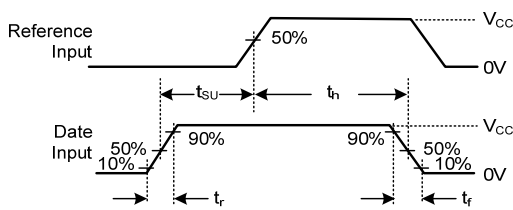

Voltage Waveforms Setup and Hold Times

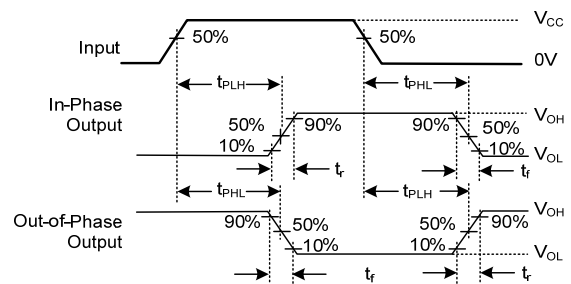

Voltage Waveforms Propagation Delay and Output Transition Times

- Notes:
1. C_L includes probe and jig capacitance.
 2. All input pulses are supplied by generators having the following characteristics: PRR ≤ 1 MHz, $Z_O = 50\Omega$, $t_r = 6$ ns, $t_f = 6$ ns.
 3. For clock inputs, fmax is measured when the input duty cycle is 50%.
 4. The outputs are measured one at a time with one input transition per measurement.

UTC assumes no responsibility for equipment failures that result from using products at values that exceed, even momentarily, rated values (such as maximum ratings, operating condition ranges, or other parameters) listed in products specifications of any and all UTC products described or contained herein. UTC products are not designed for use in life support appliances, devices or systems where malfunction of these products can be reasonably expected to result in personal injury. Reproduction in whole or in part is prohibited without the prior written consent of the copyright owner. UTC reserves the right to make changes to information published in this document, including without limitation specifications and product descriptions, at any time and without notice. This document supersedes and replaces all information supplied prior to the publication hereof.