



### 1.4MHz, 1.2A, $V_{FB}=0.6V$ SYNCHRONOUS STEP-DOWN CONVERTER

#### DESCRIPTION

UTC **UD05122** is a 1.4MHz constant frequency current mode PWM step-down converter. It is ideal for portable equipment requiring very high current up to 1.2A from single-cell Lithium-ion batteries while still achieving over 90% efficiency during peak load conditions. The 2.5V to 5.5V input voltage range makes UTC **UD05122** ideally suited for single Li-Ion, two to four AA battery-powered applications. 100% duty cycle provides low dropout operation, extending battery life in portable systems. Pulse skipping mode operation provides very low output ripple voltage for noise sensitive applications. Switching frequency is internally set at 1.4MHz, allowing the use of small surface mount inductors and capacitors. The internal synchronous switch increases efficiency and decreases need of an external Schottky diode. Low output voltages are easily supported with the 0.6V feedback reference voltage.

#### FEATURES

- \* Input Voltage Range :2.5V~5.5V
- \* Output Voltage: from 0.6V to  $V_{IN}$
- \* High Efficiency: Up to 92%
- \* Constant Frequency Operation:1.4MHz
- \* Output Current:1.2A
- \* Quiescent Current: 200uA (input < 4.2V)
- \* No Schottky Diode Required
- \* 100% Duty Cycle in Dropout
- \* 0.6V Reference Allows Low Output Voltages
- \* Current Mode Operation for Excellent Line and Load Transient Response
- \* Current limit, Enable function
- \* Short Circuit Protect (SCP)
- \*  $\leq 1\mu A$  Shutdown Current

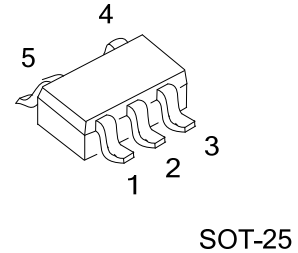

### ■ ORDERING INFORMATION

Ordering Number		Package	Packing
Lead Free	Halogen Free		
UD05122L-AF5-R	UD05122G-AF5-R	SOT-25	Tape Reel

<p>UD05122G-AF5-R</p> <p>(1) Packing Type (2) Package Type (3) Green Package</p>	<p>(1) R: Tape Reel (2) AF5: SOT-25 (3) G: Halogen Free and Lead Free, L: Lead Free</p>
--	---

### ■ MARKING

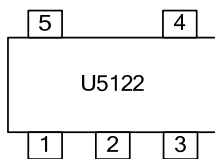

■ PIN CONFIGURATION

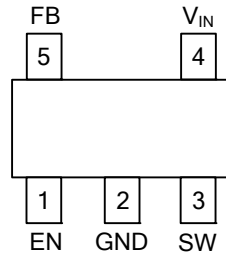

■ PIN DESCRIPTION

PIN NO.	PIN NAME	DESCRIPTION
1	EN	Enable pin H: normal operation L: Shutdown
2	GND	Ground Pin
3	SW	Switch output pin. Connect external inductor here. Minimize trace area at this pin to reduce EMI.
4	V <sub>IN</sub>	Power Supply Input Pin
5	FB	Output Feedback pin

■ BLOCK DIAGRAM

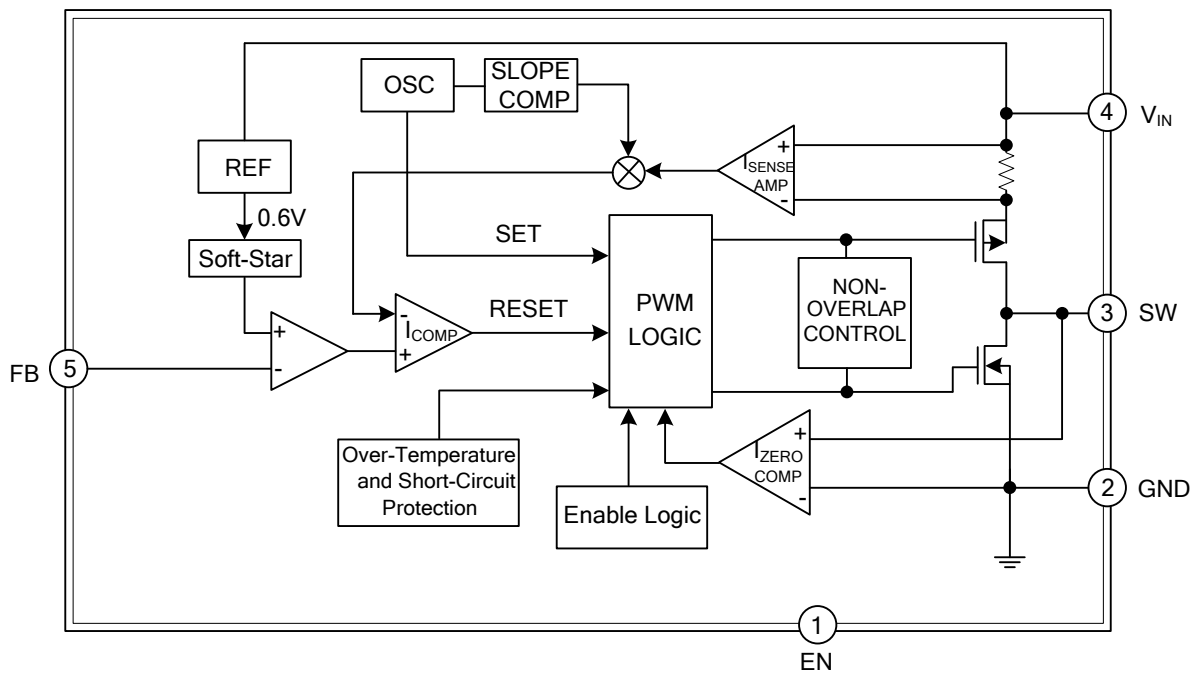

■ ABSOLUTE MAXIMUM RATING ( $T_A=25^{\circ}\text{C}$ , unless otherwise specified)

PARAMETER	SYMBOL	RATINGS	UNIT
$V_{IN}$ Pin Voltage	$V_{IN}$	6	V
Feedback Pin Voltage	$V_{FB}$	$V_{CC}$	V
EN Pin Voltage	$V_{EN}$	$V_{CC}$	V
Switch Pin Voltage	$V_{SW}$	$V_{CC}$	V
Peak SW Sink and Source Current	$I_{PSW}$	1.5	A
Junction Temperature	$T_J$	+125	$^{\circ}\text{C}$
Storage Temperature Range	$T_{STG}$	-40 ~ +150	$^{\circ}\text{C}$
Operation Temperature Range	$T_{OPR}$	-40 ~ +85	$^{\circ}\text{C}$

Note: Absolute maximum ratings are those values beyond which the device could be permanently damaged. Absolute maximum ratings are stress ratings only and functional device operation is not implied.

■ THERMAL CHARACTERISTICS

PARAMETER	SYMBOL	RATINGS	UNIT
Junction to Ambient	$\theta_{JA}$	26.0	$^{\circ}\text{C}/\text{W}$

Note:  $\theta_{JA}$  is measured with the PCB copper area of approximately 1 in<sup>2</sup>(Multi-layer). That need connect to GND pin of the UTC **UD05122**.

■ ELECTRICAL CHARACTERISTICS ( $V_{IN}=V_{EN}=3.6\text{V}$ ,  $T_A=25^{\circ}\text{C}$ , unless otherwise specified) (Note 1)

PARAMETER	SYMBOL	TEST CONDITIONS	MIN	TYP	MAX	UNIT
Input Voltage Range	$V_{IN}$		2.5		5.5	V
Feedback Voltage	$V_{FB}$	$V_{FB}=0.6\text{V}$	0.588	0.600	0.612	V
Feedback Bias Current	$I_{FB}$	$V_{FB}=0.65\text{V}$	-30		+30	nA
Quiescent Current	$I_{CC}$	$V_{FB}=1\text{V}$		200	400	$\mu\text{A}$
Shutdown Supply Current	$I_{SD}$	$V_{EN}=0\text{V}$		0.1	1	$\mu\text{A}$
Switching Current Limit	$I_{LIMIT}$	$V_{IN}=5\text{V}$		1.8		A
Oscillation Frequency	$F_{OSC}$	SW pin	1.2	1.4	1.6	MHz
$R_{DS(ON)}$ of P-CH MOSFET	$R_{DSON}$	$I_{OUT}=1.0\text{A}$		0.26	0.33	$\Omega$
$R_{DS(ON)}$ of N-CH MOSFET	$R_{DSON}$	$I_{OUT}=1.0\text{A}$		0.26	0.33	$\Omega$
Efficiency	EFFI	$V_{IN}=5\text{V}$ , $V_{OUT}=3.3\text{V}$ , $I_{OUT}=0.5\text{A}$	92			%
EN Pin Logic Input Threshold Voltage	$V_{ENL}$				0.6	V
	$V_{ENH}$		1.2			V
EN Pin Input Current	$I_{EN}$			$\pm 0.1$	$\pm 1$	$\mu\text{A}$
Soft-Start Interval	$T_{SS}$			1.2		ms

Note: 100% production test at +25 $^{\circ}\text{C}$ . Specifications over the temperature range are guaranteed by design and characterization.

■ TYPICAL APPLICATION CIRCUIT

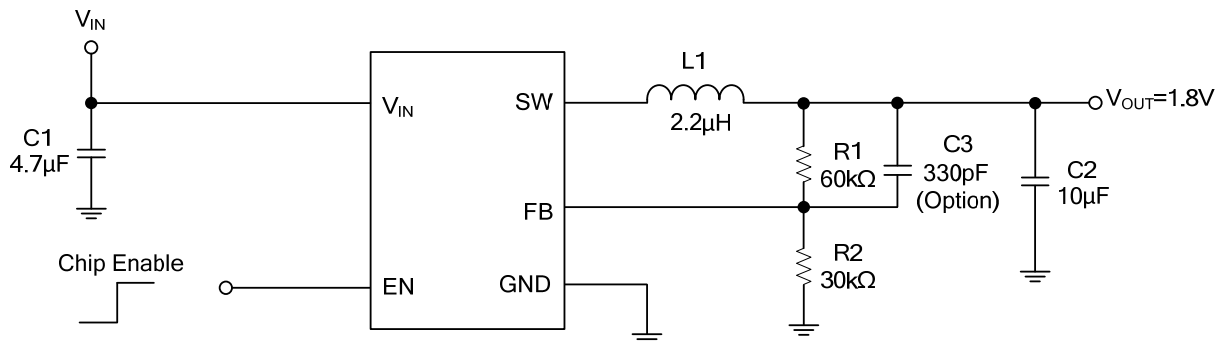

$$V_{OUT} = 0.6 \times (1 + R1/R2)$$

UTC assumes no responsibility for equipment failures that result from using products at values that exceed, even momentarily, rated values (such as maximum ratings, operating condition ranges, or other parameters) listed in products specifications of any and all UTC products described or contained herein. UTC products are not designed for use in life support appliances, devices or systems where malfunction of these products can be reasonably expected to result in personal injury. Reproduction in whole or in part is prohibited without the prior written consent of the copyright owner. UTC reserves the right to make changes to information published in this document, including without limitation specifications and product descriptions, at any time and without notice. This document supersedes and replaces all information supplied prior to the publication hereof.