



## 1NM70

Power MOSFET

### 1A, 700V N-CHANNEL SUPER-JUNCTION MOSFET

#### DESCRIPTION

The UTC **1NM70** is a Super Junction MOSFET Structure and is designed to have better characteristics, such as fast switching time, low gate charge, low on-state resistance and have a high rugged avalanche characteristics. This power MOSFET is usually used at high speed switching applications in power supplies, PWM motor controls, high efficient DC to DC converters and bridge circuits.

#### FEATURES

- \*  $R_{DS(ON)} < 3.9\Omega @ V_{GS}=10V, I_D=0.5A$
- \* Fast switching capability
- \* Avalanche energy specified
- \* Improved dv/dt capability, high ruggedness

#### SYMBOL

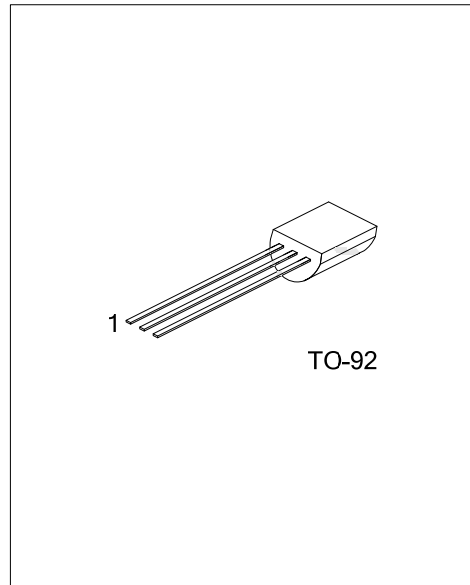
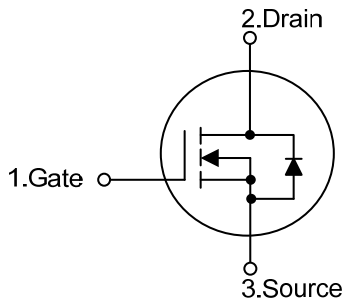

#### ORDERING INFORMATION

Ordering Number		Package	Pin Assignment			Packing
Lead Free	Halogen Free		1	2	3	
1NM70L-T92-B	1NM70G-T92-B	TO-92	G	D	S	Tape Box
1NM70L-T92-K	1NM70G-T92-K	TO-92	G	D	S	Bulk

Note: Pin Assignment: G: Gate D: Drain S: Source

<p>1NM70G-T92-B</p>	<p>(1) B: Tape Box, K: Bulk (2) T92: TO-92 (3) G: Halogen Free and Lead Free, L: Lead Free</p>
---------------------	--

■ MARKING

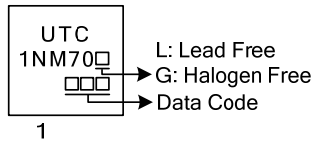

■ ABSOLUTE MAXIMUM RATINGS ( $T_C=25^\circ\text{C}$ , unless otherwise specified)

PARAMETER	SYMBOL	RATINGS	UNIT
Drain-Source Voltage	$V_{DSS}$	700	V
Gate-Source Voltage	$V_{GSS}$	$\pm 30$	V
Continuous Drain Current	$I_D$	1.0	A
Pulsed Drain Current (Note 2)	$I_{DM}$	4.0	A
Avalanche Energy (Note 3)	$E_{AS}$	68	mJ
Single Pulsed			
Peak Diode Recovery dv/dt (Note 4)	dv/dt	12.5	V/ns
Power Dissipation	$P_D$	1.6	W
Junction Temperature	$T_J$	+150	$^\circ\text{C}$
Storage Temperature	$T_{STG}$	-55 ~ +150	$^\circ\text{C}$

- Notes: 1. Absolute maximum ratings are those values beyond which the device could be permanently damaged. Absolute maximum ratings are stress ratings only and functional device operation is not implied.  
 2. Repetitive Rating: Pulse width limited by maximum junction temperature.  
 3.  $L=138\text{mH}$ ,  $I_{AS}=1.0\text{A}$ ,  $V_{DD}=50\text{V}$ ,  $R_G=25\ \Omega$ , Starting  $T_J = 25^\circ\text{C}$   
 4.  $I_{SD} \leq 1.0\text{A}$ ,  $di/dt \leq 200\text{A}/\mu\text{s}$ ,  $V_{DD} \leq BV_{DSS}$ , Starting  $T_J = 25^\circ\text{C}$

■ THERMAL DATA

PARAMETER	SYMBOL	RATINGS	UNIT
Junction to Ambient	$\theta_{JA}$	140	$^\circ\text{C}/\text{W}$
Junction to Case	$\theta_{JC}$	79	$^\circ\text{C}/\text{W}$

■ ELECTRICAL CHARACTERISTICS ( $T_C=25^\circ\text{C}$ , unless otherwise specified)

PARAMETER	SYMBOL	TEST CONDITIONS	MIN	TYP	MAX	UNIT
<b>OFF CHARACTERISTICS</b>						
Drain-Source Breakdown Voltage	$BV_{DSS}$	$V_{GS} = 0\text{V}$ , $I_D = 250\mu\text{A}$	700			V
Drain-Source Leakage Current	$I_{DSS}$	$V_{DS} = 700\text{V}$ , $V_{GS} = 0\text{V}$			10	$\mu\text{A}$
Gate-Source Leakage Current	$I_{GSS}$	Forward			100	nA
		Reverse	$V_{GS} = 30\text{V}$ , $V_{DS} = 0\text{V}$			-100
<b>ON CHARACTERISTICS</b>						
Gate Threshold Voltage	$V_{GS(TH)}$	$V_{DS} = V_{GS}$ , $I_D = 250\mu\text{A}$	2.5		4.5	V
Static Drain-Source On-State Resistance	$R_{DS(ON)}$	$V_{GS} = 10\text{V}$ , $I_D = 0.5\text{A}$			3.9	$\Omega$
<b>DYNAMIC CHARACTERISTICS</b>						
Input Capacitance	$C_{ISS}$	$V_{DS} = 25\text{V}$ , $V_{GS} = 0\text{V}$ , $f = 1\text{MHz}$		77		pF
Output Capacitance	$C_{OSS}$			78.5		pF
Reverse Transfer Capacitance	$C_{RSS}$			7.5		pF
<b>SWITCHING CHARACTERISTICS</b>						
Total Gate Charge	$Q_G$	$V_{DS}=400\text{V}$ , $V_{GS}=10\text{V}$ , $I_D=1.0\text{A}$ , $I_G=1\text{mA}$ (Note 1, 2)		8.6		nC
Gate-Source Charge	$Q_{GS}$			3.6		nC
Gate-Drain Charge	$Q_{GD}$			0.8		nC
Turn-On Delay Time	$t_{D(ON)}$	$V_{DD}=350\text{V}$ , $V_{GS}=10\text{V}$ , $I_D=1\text{A}$ , $R_G=25\Omega$ (Note 1, 2)		6		ns
Turn-On Rise Time	$t_R$			20		ns
Turn-Off Delay Time	$t_{D(OFF)}$			36		ns
Turn-Off Fall Time	$t_F$			50		ns
<b>DRAIN-SOURCE DIODE CHARACTERISTICS</b>						
Maximum Body-Diode Continuous Current	$I_S$				1.0	A
Continuous Drain-Source Current	$I_{SD}$				4.0	A
Drain-Source Diode Forward Voltage	$V_{SD}$	$I_S=1.0\text{A}$ , $V_{GS}=0\text{V}$			1.4	V
Reverse Recovery Time	$t_{rr}$	$I_F=1.0\text{A}$ , $V_{DD}=400\text{V}$		78		ns
Reverse Recovery Charge	$Q_{rr}$	$di/dt = 100\text{A}/\mu\text{s}$		0.18		$\mu\text{C}$

- Notes: 1. Pulse Test: Pulse width  $\leq 300\mu\text{s}$ , Duty cycle  $\leq 2\%$ .  
 2. Essentially independent of operating temperature.

## ■ TEST CIRCUITS AND WAVEFORMS

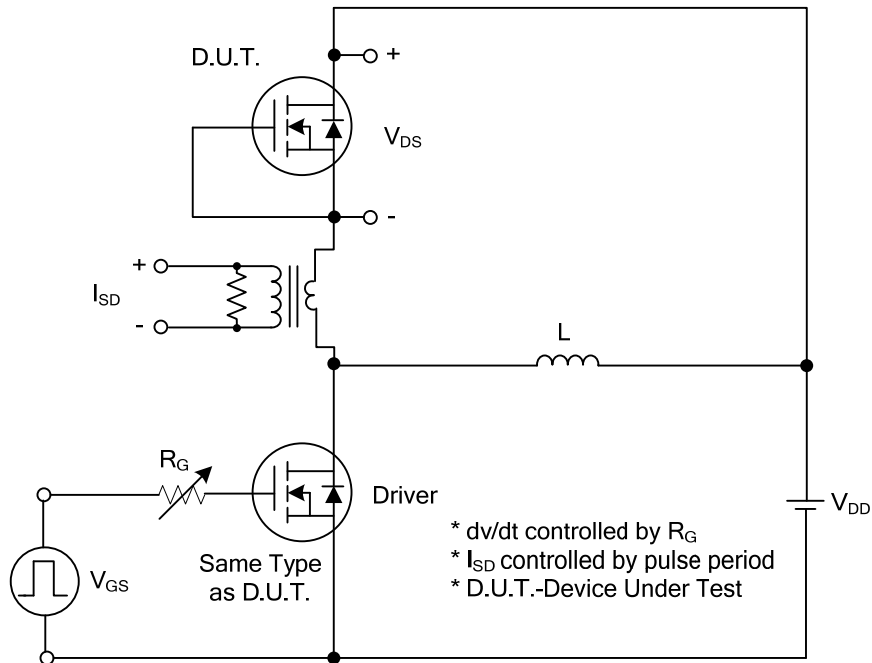

**Peak Diode Recovery  $dv/dt$  Test Circuit**

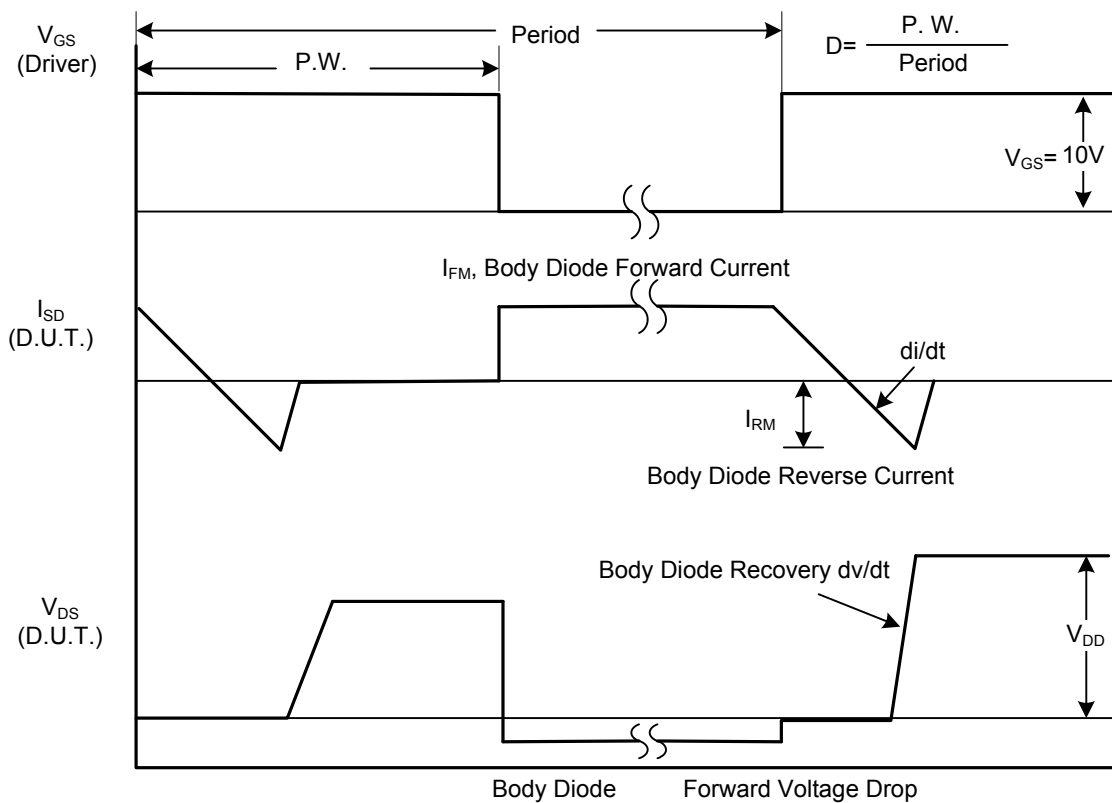

**Peak Diode Recovery  $dv/dt$  Waveforms**

## TEST CIRCUITS AND WAVEFORMS (Cont.)

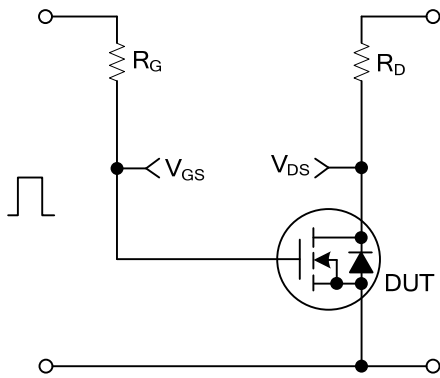

**Switching Test Circuit**

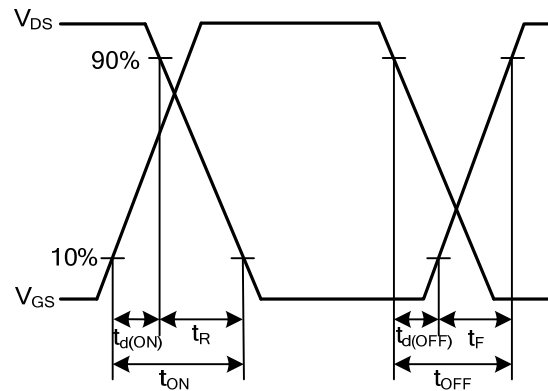

**Switching Waveforms**

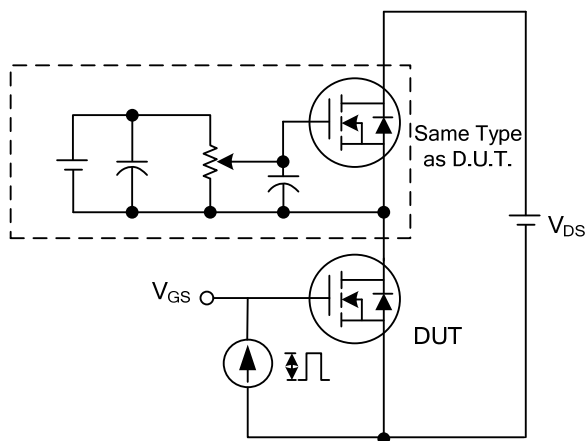

**Gate Charge Test Circuit**

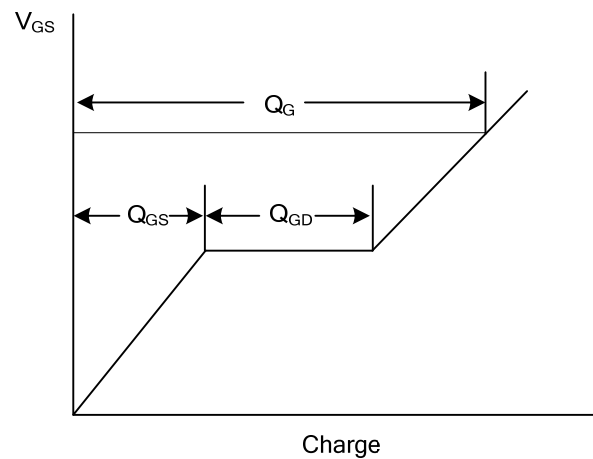

**Gate Charge Waveform**

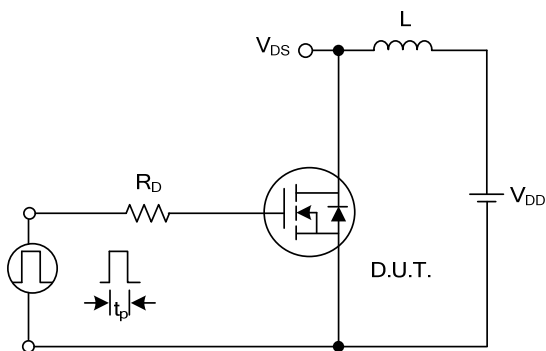

**Unclamped Inductive Switching Test Circuit**

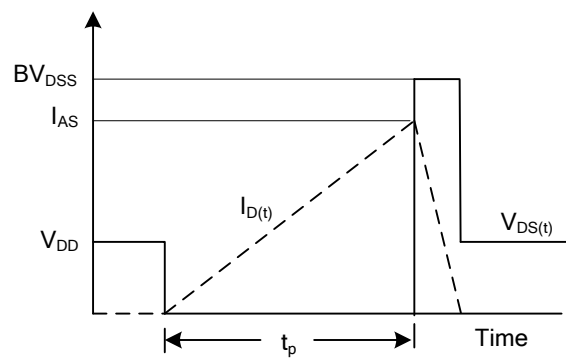

**Unclamped Inductive Switching Waveforms**

## TYPICAL CHARACTERISTICS

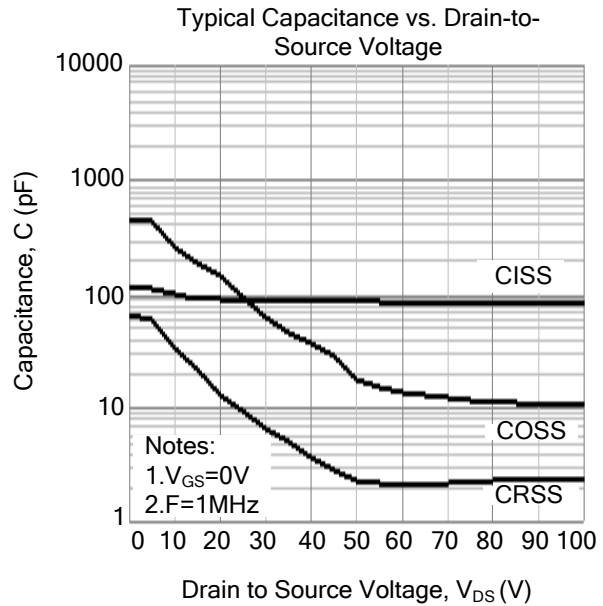
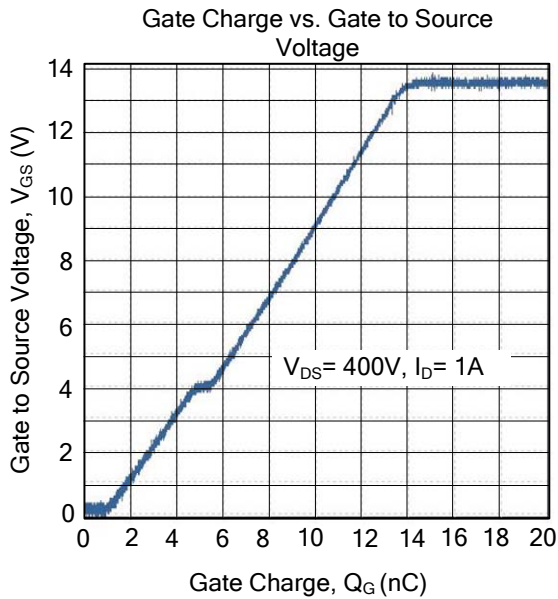

UTC assumes no responsibility for equipment failures that result from using products at values that exceed, even momentarily, rated values (such as maximum ratings, operating condition ranges, or other parameters) listed in products specifications of any and all UTC products described or contained herein. UTC products are not designed for use in life support appliances, devices or systems where malfunction of these products can be reasonably expected to result in personal injury. Reproduction in whole or in part is prohibited without the prior written consent of the copyright owner. UTC reserves the right to make changes to information published in this document, including without limitation specifications and product descriptions, at any time and without notice. This document supersedes and replaces all information supplied prior to the publication hereof.