

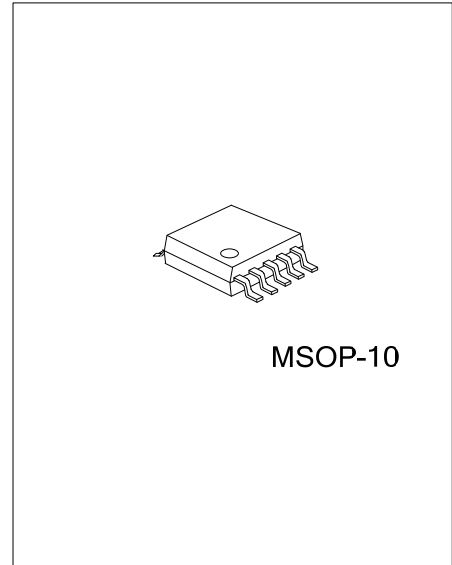

UCC40702

CMOS IC

40V SYNCHRONOUS BUCK CONTROLLER WITH 2CH CC/CV



MSOP-10

DESCRIPTION

The UTC **UCC40702** is a synchronous buck controller. The device need externals high side and external low side power MOSFETs, and provides 5A of continuous load current and a wide input voltage of 8V to 40V. Current mode control provides fast transient response and cycle-by-cycle current limit. An internal soft-start prevents inrush current at turn-on.

FEATURES

- * Wide 8V ~ 40V Operating Input Range
- * Externals high side and low side Power MOSFET Switches
- * Output Adjustable from $V_{FB}(1.00V\pm 2\%)$ to 16V
- * Up to 95% Efficiency
- * Internal Soft-Start and Fixed 160KHz Frequency
- * Duty on ratio : 0% ~ 91% PWM control
- * Cycle-by-Cycle Over Current Protection
- * Input Under/Over Voltage Lockout

ORDERING INFORMATION

Ordering Number		Package	Packing
Lead Free	Halogen Free		
UCC40702L-SM2-R	UCC40702G-SM2-R	MSOP-10	Tape Reel

<p>UCC40702G-SM2-R</p> <ul style="list-style-type: none"> (1) Packing Type (2) Package Type (3) Green Package 	<ul style="list-style-type: none"> (1) R: Tape Reel (2) SM2: MSOP-10 (3) G: Halogen Free and Lead Free, L: Lead Free
--	---

MARKING

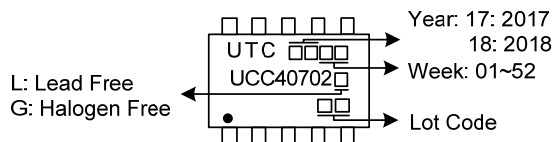

■ PIN CONFIGURATION

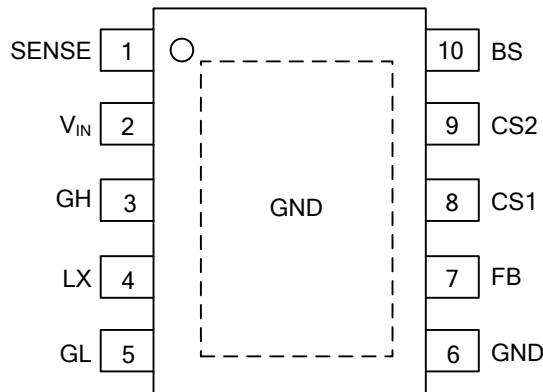

■ PIN DESCRIPTION

PIN NO.	PIN NAME	DESCRIPTION
1	SENSE	Power Input Current limit sense.
2	V _{IN}	Power Input pin. Bypass IN to GND with a suitably large capacitor to eliminate noise on the input to the IC.
3	GH	Gate drive for external high side N-MOSFET..
4	LX	Switching sense.
5	GL	Gate drive for external low side N-MOSFET..
6	GND	Power Ground.
7	FB	Feedback Input. FB senses the output voltage to regulate that voltage. Drive FB with a resistive voltage divider from the output voltage.
8	CS1	The Current Sense 1 pin.
9	CS2	The Current Sense 2 pin.
10	BS	Boot-Strap Pin. Supply high side gate driver. Decouple this pin to LX pin with 0.1uF ceramic cap.

■ BLOCK DIAGRAM

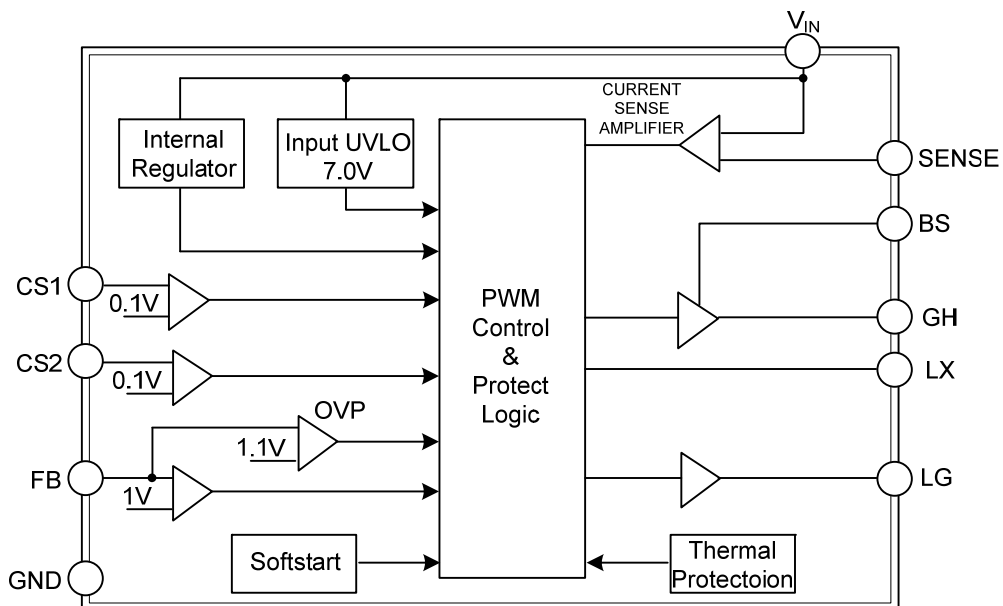

■ ABSOLUTE MAXIMUM RATING ($T_A=25^{\circ}\text{C}$, unless otherwise specified)

PARAMETER	SYMBOL	RATINGS	UNIT
Supply Voltage	V_{IN}	-0.3 ~ +42	V
Switch Node Voltage	V_{SW}	-0.3 ~ $V_{IN}+0.3$	V
Boost Voltage	V_{BS}	$V_{SW}-0.3 \sim V_{SW}+6$	V
All Other Pins		-0.3 ~ +6	V
Output Voltage	V_{OUT}	$V_{FB} \sim 20$	V
Junction Temperature	T_J	+150	$^{\circ}\text{C}$
Storage Temperature	T_{STG}	-65 ~ +150	$^{\circ}\text{C}$

Note: Absolute maximum ratings are those values beyond which the device could be permanently damaged. Absolute maximum ratings are stress ratings only and functional device operation is not implied.

■ THERMAL CHARACTERISTICS

PARAMETER	SYMBOL	RATINGS	UNIT
Junction to Ambient	θ_{JA}	90	$^{\circ}\text{C}/\text{W}$
Junction to Case	θ_{JC}	40	$^{\circ}\text{C}/\text{W}$

Note: θ_{JA} is measured with the PCB copper area of approximately 1 in^2 (Multi-layer). That need connect to exposed pad.

■ ELECTRICAL CHARACTERISTICS ($V_{IN}=12\text{V}$, $T_A=25^{\circ}\text{C}$, unless otherwise specified)

PARAMETER	SYMBOL	TEST CONDITIONS	MIN	TYP	MAX	UNIT
Input Voltage Range			8		40	V
Quiescent Current	I_{CCQ}	$V_{FB}=1.05\text{V}$		1	1.5	mA
Feedback Voltage	V_{FB}	$8\text{V} \leq V_{IN} \leq 38\text{V}$	0.98	1.00	1.02	V
Feedback Overvoltage Threshold	$\text{OVP}_{(FB)}$			1.1X		V_{FB}
Line Compensation Current (Note 1)	I_{CFB}	$V_{CS}=100\text{mV}$		4		μA
GH Rise Time	T_{GHR}	$C_{LX}=1200\text{pF}$		40		ns
GH Fall Time	T_{GHF}	$C_{LX}=1200\text{pF}$		40		ns
GL Rise Time	T_{GLR}	$C_{LX}=1200\text{pF}$		40		ns
GL Fall Time	T_{GLF}	$C_{LX}=1200\text{pF}$		40		ns
LG Driver Bias Supply Voltage				5		V
Oscillation Frequency	F_{OSC1}			160		KHz
Short Circuit Oscillation Frequency	F_{OSC2}	$V_{FB} < 0.4\text{V}$		80		KHz
Short Circuit Retry Time (Note 1)	RT_{SCP}	$V_{FB} < 0.5\text{V}$		2		mS
Maximum Duty Cycle	D_{MAX}			91		%
Minimum On Time (Note 1)	$T_{ON(min)}$			220		ns
Current Sense Voltage	$V_{CS1/2}$		90	100	115	mV
Input Under Voltage Lockout Threshold	UVLO	V_{IN} Rising	6.5	7.2	7.8	V
Input Under Voltage Lockout Threshold Hysteresis	UVLO-Hys			800		mV
Input Over Voltage Lockout Threshold	OVLO	V_{IN} Rising		41		V
Input Over Voltage Lockout Threshold Hysteresis	OVLO-Hys			3		V
Soft-Start Period				2		ms
Thermal Shutdown	T_{SD}			150		$^{\circ}\text{C}$
Thermal Shutdown Hysteresis	T_{SH}			30		$^{\circ}\text{C}$

Note: Guaranteed by design.

■ FUNCTION DESCRIPTIONS

The **UCC40702** is a synchronous rectified, current-mode step-down controller. It regulates input voltages from 8V to 40V down to an output voltage, and supplies up to 5A of load current.

The **UCC40702** uses current-mode control to regulate the output voltage. The output voltage is measured at FB through a resistive voltage divider and amplified through the internal Transconductance error amplifier. The voltage at the COMP pin is compared to the switch current measured internally to control the output voltage.

The controller uses external N-Channel MOSFET switches to step-down the input voltage to the regulated output voltage. Since the high side MOSFET requires a gate voltage greater than the input voltage, a boost capacitor connected between SW and BS is needed to drive the high side gate. The boost capacitor is charged from the internal 5V rail when SW is low.

When the **UCC40702** FB pin exceeds 10% of the nominal regulation voltage of VFB, the over voltage comparator is tripped and the COMP pin is discharged to GND, forcing the high-side switch off.

■ APPLICATION INFORMATION

Setting the Output Voltage

The output voltage is set using a resistive voltage divider from the output voltage to FB pin. The voltage divider divides the output voltage down to the feedback voltage by the ratio.

Thus the output voltage is:

$$V_{OUT} = V_{FB} \times \frac{R1 + R2}{R2}$$

For example, $V_{FB} = 1.00V$ for a 5.0V output voltage, R2 is 10kΩ, and R1 is 40kΩ.

DUTY ON	<55%	55 ~ 90%
CFB	3.3nF	1nF

Inductor Selection

The inductor is required to supply constant current to the output load while being driven by the switched input voltage. A larger value inductor will result in less ripple current that will result in lower output ripple voltage. However, the larger value inductor will have a larger physical size, higher series resistance, and/or lower saturation current. A good rule for determining the inductance to use is to allow the peak-to-peak ripple current in the inductor to be approximately 30% of the maximum switch current limit.

V_{IN}	<28V	<35V
Inductor	33uH	47uH

The choice of which style inductor to use mainly depends on the price vs. size requirements and any EMI requirements.

Output Short-Circuit protection

The UTC **UCC40702** provides output short-circuit protection retry function. When V_{OUT} is short ($V_{FB} < 0.5V$), the auto restart function can be started that restart the regulator cycle by cycle. (Retry time 1mS, Shutdown regulator time 20mS).

Output Cable Resistance Compensation

To compensate for resistive voltage drop across the charger's output cable, the UTC **UCC40702** integrates a simple, user-programmable cable voltage drop compensation using the impedance at the FB pin. Use the curve in Figure 1 to choose the proper feedback resistance values for cable compensation. R1 is the high side resistor of voltage divider.

$$V_{OUT} = V_{FB} \times (1 + R1/R2) + R1 \times I_{FB} (4\mu A)$$

■ TYPICAL APPLICATION CIRCUIT

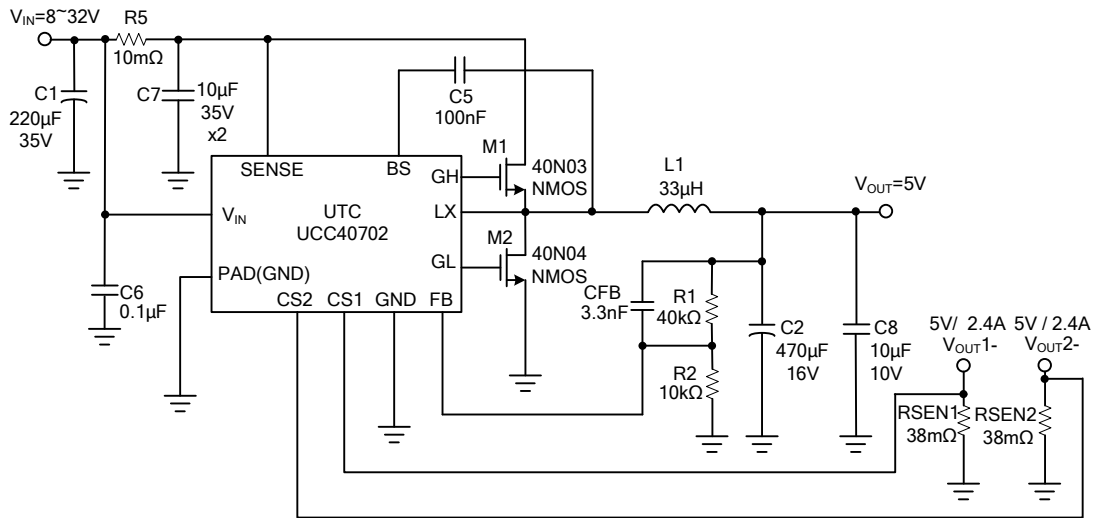

$$V_{OUT} = V_{FB} \times (1 + R1/R2), \quad V_{FB} = 1.00V, \quad R2 \text{ suggest } 1k \sim 30k\Omega$$

$$I_{SEN} = 2.63A \quad (I_{SEN} = V_{CS}(0.1V) / R_{SEN}(38m\Omega))$$

Cable Compensation at Various Resistor Divider Values

TYPICAL CHARACTERISTICS

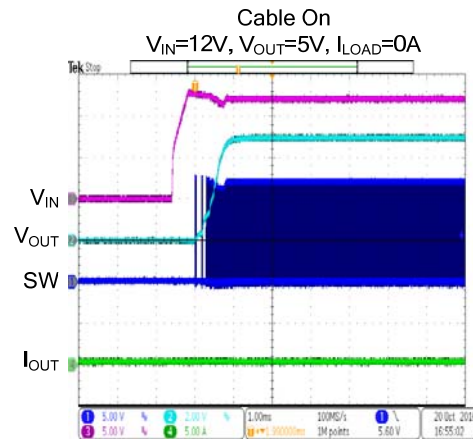
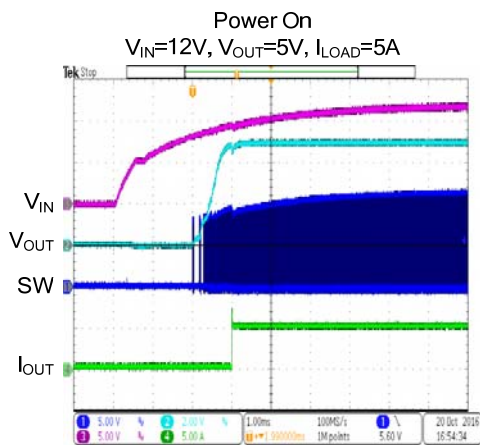
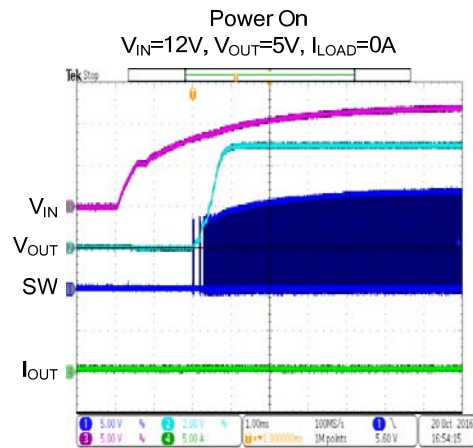
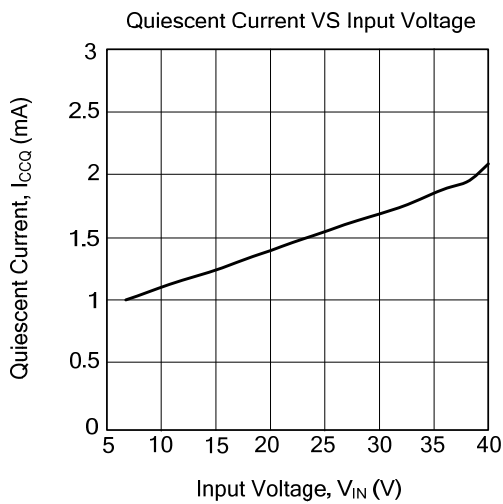
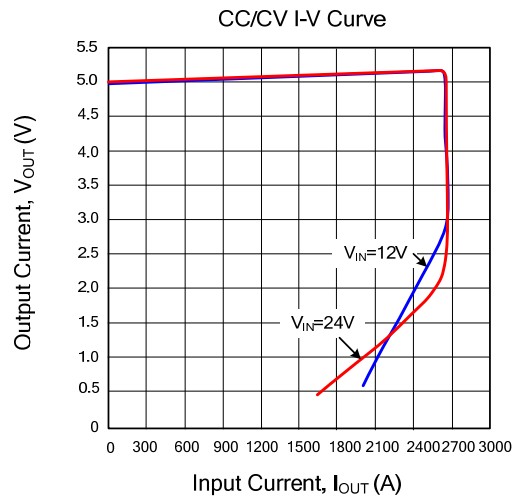
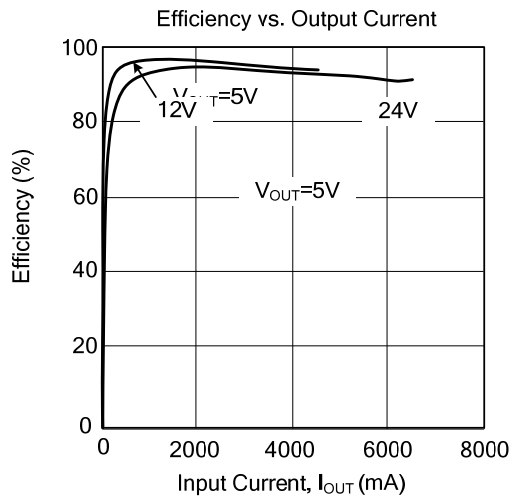

TYPICAL CHARACTERISTICS

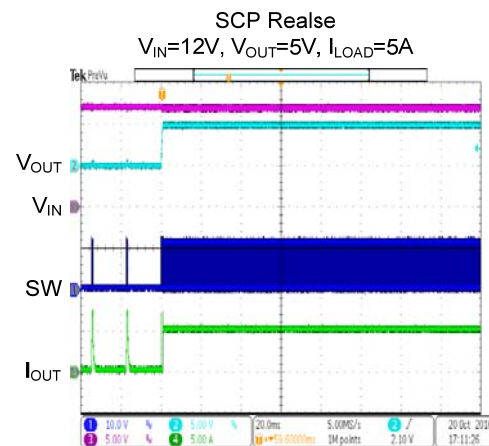
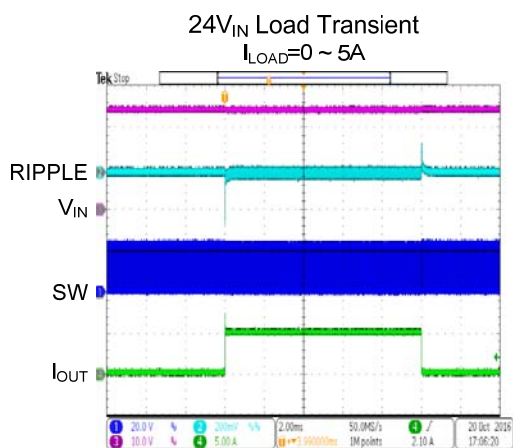
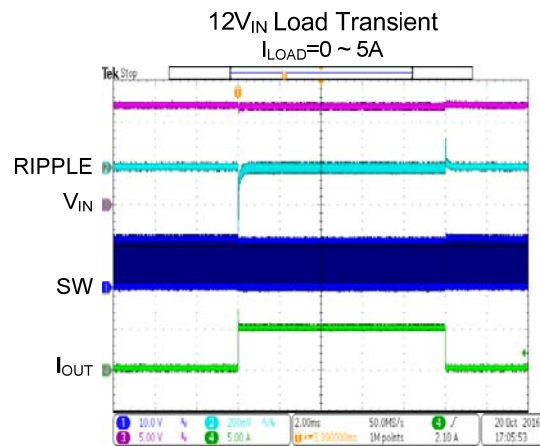
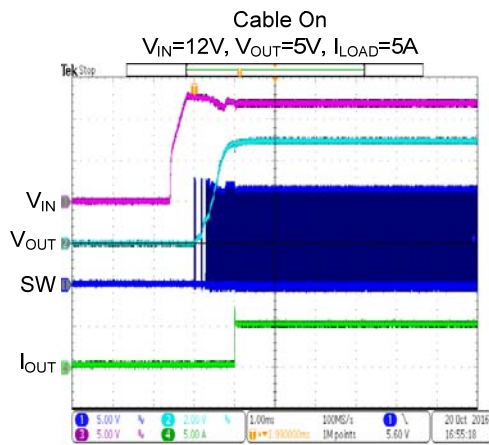

UTC assumes no responsibility for equipment failures that result from using products at values that exceed, even momentarily, rated values (such as maximum ratings, operating condition ranges, or other parameters) listed in products specifications of any and all UTC products described or contained herein. UTC products are not designed for use in life support appliances, devices or systems where malfunction of these products can be reasonably expected to result in personal injury. Reproduction in whole or in part is prohibited without the prior written consent of the copyright owner. UTC reserves the right to make changes to information published in this document, including without limitation specifications and product descriptions, at any time and without notice. This document supersedes and replaces all information supplied prior to the publication hereof.