



10NM65-FD

Power MOSFET

10A, 650V N-CHANNEL SUPER-JUNCTION MOSFET

DESCRIPTION

The **UTC 10NM65-FD** is a Super Junction MOSFET Structure and is designed to have better characteristics, such as fast switching time, low gate charge, low on-state resistance and a high rugged avalanche characteristics. This power MOSFET is usually used at DC-DC, AC-DC converters for power applications.

FEATURES

- * $R_{DS(ON)} < 0.55\Omega @ V_{GS}=10V, I_D=5.0A$
- * By using Super Junction Structure
- * Fast Switching
- * With 100% Avalanche Tested

SYMBOL

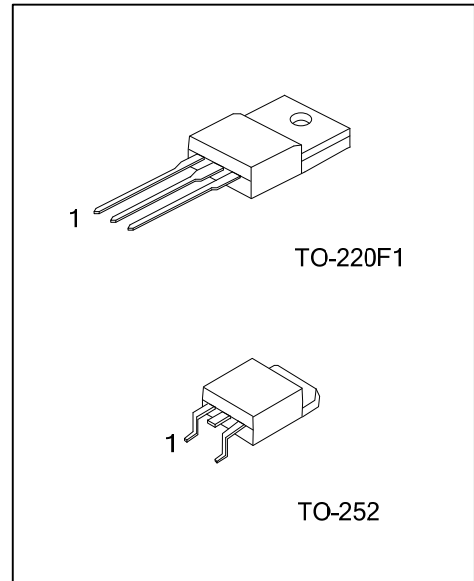
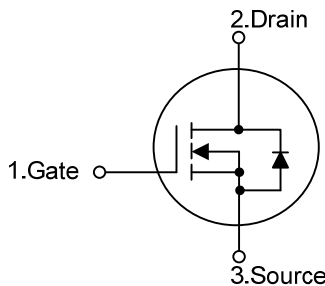

ORDERING INFORMATION

Ordering Number		Package	Pin Assignment			Packing
Lead Free	Halogen Free		1	2	3	
10NM65L-TF1-T	10NM65G-TF1-T	TO-220F1	G	D	S	Tube
10NM65L-TN3-R	10NM65G-TN3-R	TO-252	G	D	S	Tape Reel

Note: Pin Assignment: G: Gate D: Drain S: Source

<p>10NM65G-TF1-T</p> <p>(1)Packing Type</p> <p>(2)Package Type</p> <p>(3)Green Package</p>	<p>(1) T: Tube, R: Tape Reel</p> <p>(2) TF1: TO-220F1, TN3: TO-252</p> <p>(3) G: Halogen Free and Lead Free, L: Lead Free</p>
--	---

MARKING

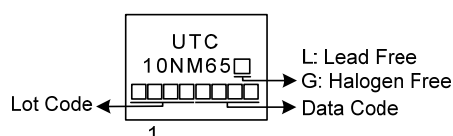

■ ABSOLUTE MAXIMUM RATINGS (T_c =25°C, unless otherwise specified)

PARAMETER		SYMBOL	RATINGS	UNIT
Drain-Source Voltage		V _{DSS}	650	V
Gate-Source Voltage		V _{GSS}	±30	V
Drain Current	Continuous	I _D	10	A
	Pulsed (Note 2)	I _{DM}	30	A
Avalanche Energy	Single Pulsed (Note 3)	E _{AS}	318	mJ
Peak Diode Recovery dv/dt (Note 4)		dv/dt	15	V/ns
Power Dissipation	TO-220F1	P _D	50	W
	TO-252		75	W
Junction Temperature		T _J	+150	°C
Storage Temperature Range		T _{STG}	-55 ~ +150	°C

Notes: 1. Absolute maximum ratings are those values beyond which the device could be permanently damaged. Absolute maximum ratings are stress ratings only and functional device operation is not implied.

2. Repetitive Rating : Pulse width limited by maximum junction temperature.
3. L=144mH, I_{AS}=2.1A, V_{DD}= 50V, R_G=25Ω, Starting T_J=25°C
4. I_{SD} ≤10A, di/dt ≤200A/μs, V_{DD} ≤BV_{DSS}, Starting T_J=25°C

■ THERMAL DATA

PARAMETER		SYMBOL	RATING	UNIT
Junction to Ambient	TO-220F1	θ _{JA}	62.5	°C/W
	TO-252		110	°C/W
Junction to Case	TO-220F1	θ _{JC}	2.5	°C/W
	TO-252		1.67	°C/W

■ ELECTRICAL CHARACTERISTICS (T_J=25°C, unless otherwise specified)

PARAMETER	SYMBOL	TEST CONDITIONS	MIN	TYP	MAX	UNIT
OFF CHARACTERISTICS						
Drain-Source Breakdown Voltage	BV _{DSS}	V _{GS} =0V, I _D =250μA	650			V
Drain-Source Leakage Current	I _{DSS}	V _{DS} =650V, V _{GS} =0V			10	μA
Gate-Source Leakage Current	I _{GSS}	Forward			100	nA
		Reverse			-100	nA
ON CHARACTERISTICS						
Gate Threshold Voltage	V _{GS(TH)}	V _{DS} = V _{GS} , I _D =250μA	2.5		4.5	V
Drain-Source On-State Resistance	R _{DS(ON)}	V _{GS} =10V, I _D =5.0A			0.55	Ω
DYNAMIC PARAMETERS						
Input Capacitance	C _{ISS}	V _{GS} =0V, V _{DS} =25V, f=1.0MHz		660		pF
Output Capacitance	C _{OSS}			570		pF
Reverse Transfer Capacitance	C _{RSS}			50		pF
SWITCHING PARAMETERS						
Turn-ON Delay Time (Note 1)	t _{D(ON)}	V _{DD} =300V, V _{GS} =10V, I _D =10A, R _G =25Ω (Note 1, 2)		4		ns
Rise Time	t _R			15		ns
Turn-OFF Delay Time	t _{D(OFF)}			80		ns
Fall-Time	t _F			30		ns
SOURCE- DRAIN DIODE RATINGS AND CHARACTERISTICS						
Maximum Body-Diode Continuous Current	I _S				10	A
Maximum Body-Diode Pulsed Current	I _{SM}				30	A
Drain-Source Diode Forward Voltage (Note 1)	V _{SD}	I _S =10A, V _{GS} =0V			1.4	V
Body Diode Reverse Recovery Time (Note 1)	t _{rr}	I _S =10A, V _{GS} =0V, di _F /dt=100A/μs		170		ns
Body Diode Reverse Recovery Charge	Q _{rr}			1.15		μC

- Notes: 1. Pulse Test : Pulse width ≤ 300μs, Duty cycle ≤ 2%.
2. Essentially independent of operating temperature.

■ TEST CIRCUITS AND WAVEFORMS

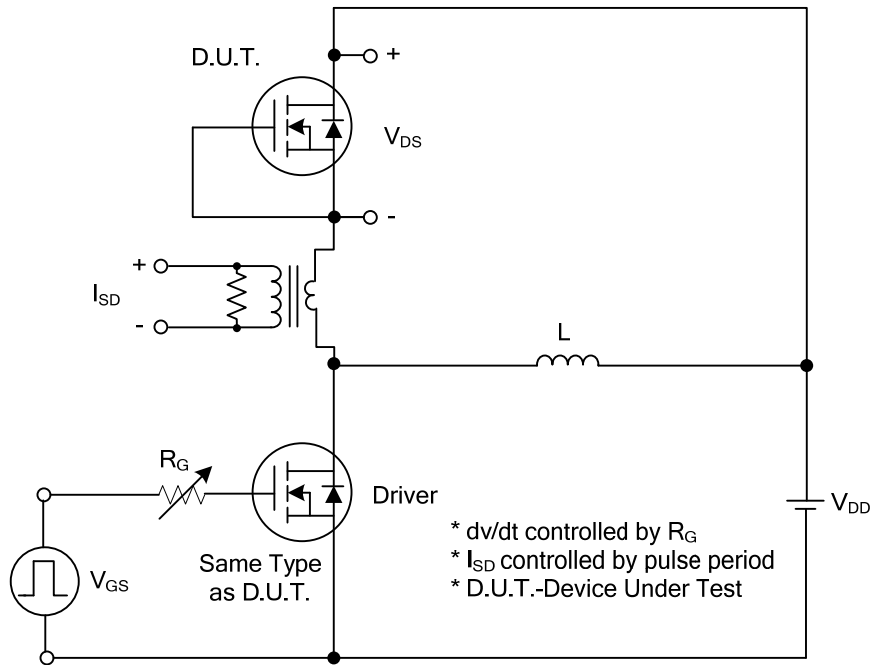

Peak Diode Recovery dv/dt Test Circuit

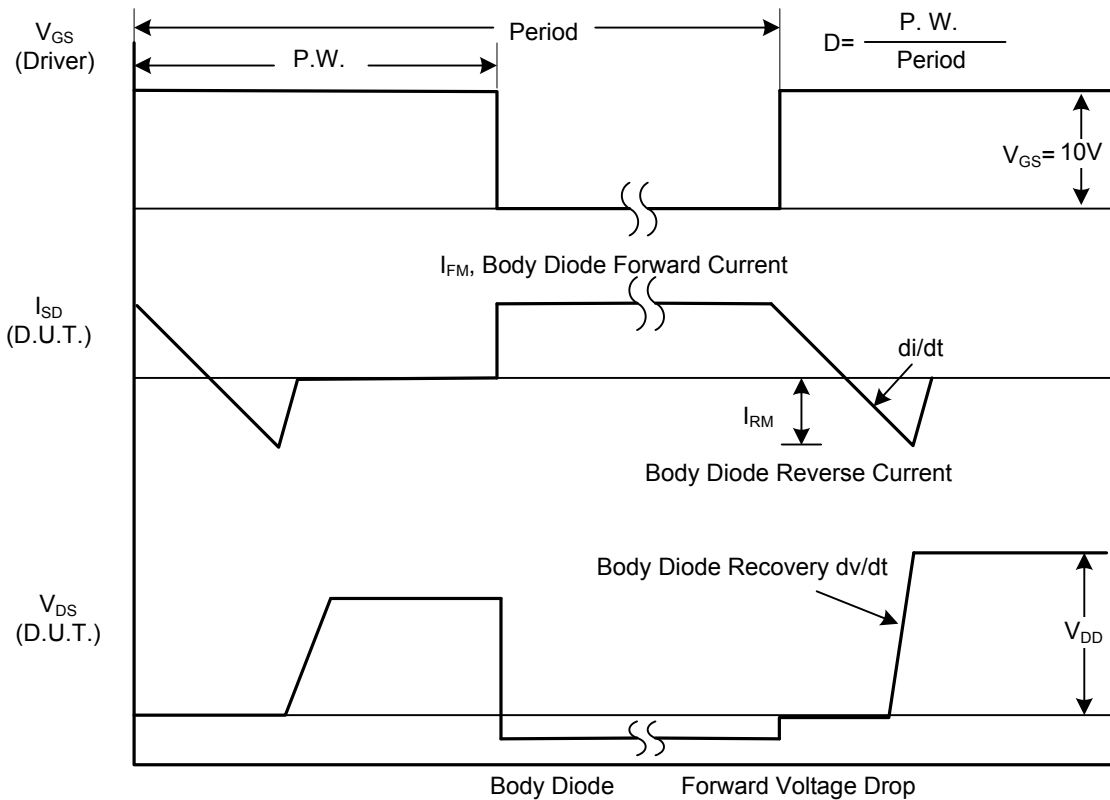

Peak Diode Recovery dv/dt Waveforms

TEST CIRCUITS AND WAVEFORMS (Cont.)

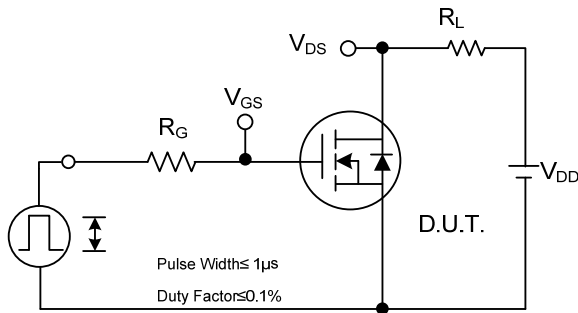

Switching Test Circuit

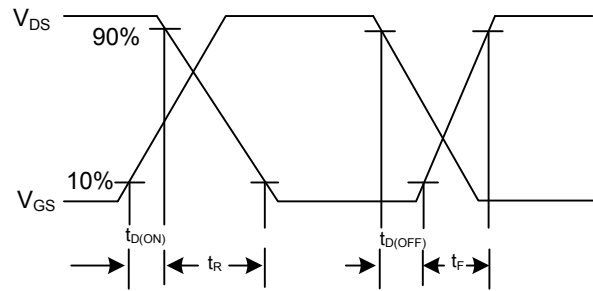

Switching Waveforms

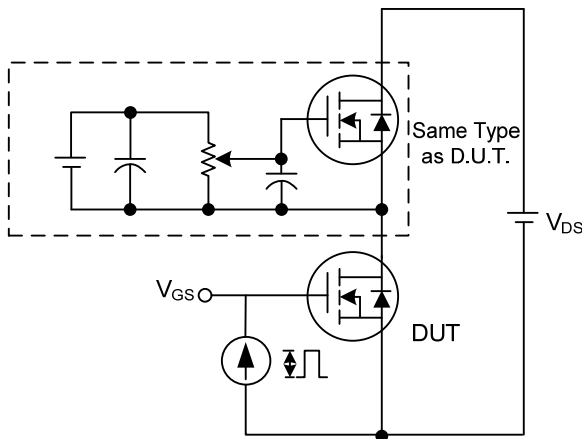

Gate Charge Test Circuit

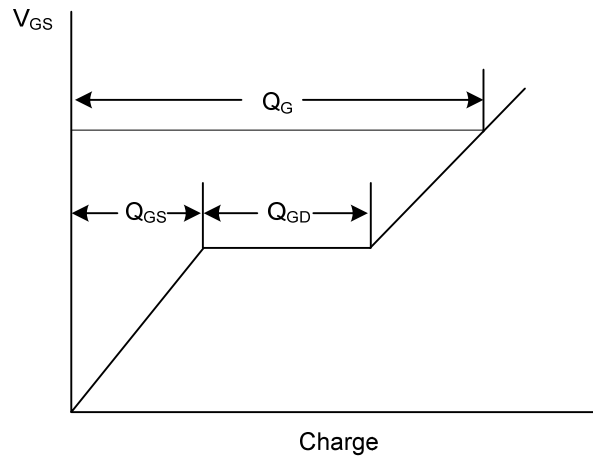

Gate Charge Waveform

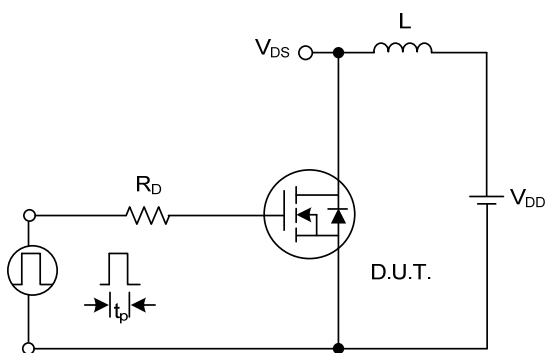

Unclamped Inductive Switching Test Circuit

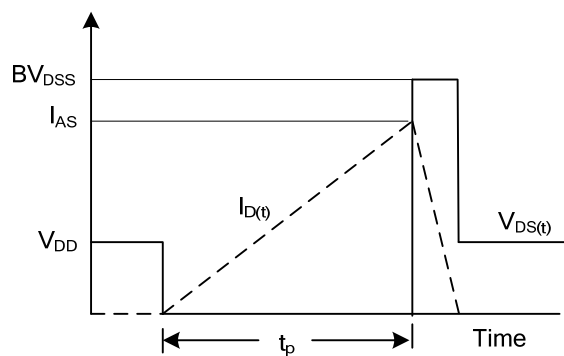

Unclamped Inductive Switching Waveforms

■ TYPICAL CHARACTERISTICS

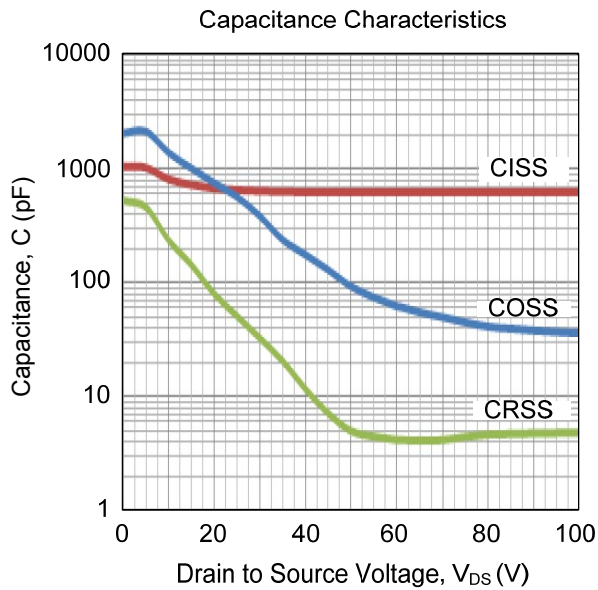

UTC assumes no responsibility for equipment failures that result from using products at values that exceed, even momentarily, rated values (such as maximum ratings, operating condition ranges, or other parameters) listed in products specifications of any and all UTC products described or contained herein. UTC products are not designed for use in life support appliances, devices or systems where malfunction of these products can be reasonably expected to result in personal injury. Reproduction in whole or in part is prohibited without the prior written consent of the copyright owner. The information presented in this document does not form part of any quotation or contract, is believed to be accurate and reliable and may be changed without notice.