



8N100-C

Power MOSFET

8.0A, 1000V N-CHANNEL POWER MOSFET

DESCRIPTION

The UTC **8N100-C** provide excellent $R_{DS(ON)}$, low gate charge and operation with low gate voltages. This device is suitable for use as a load switch or in PWM applications.

FEATURES

- * $R_{DS(ON)} \leq 1.45 \Omega @ V_{GS}=10V, I_D=4.0A$
- * Low Reverse Transfer Capacitance
- * Fast Switching Capability
- * Avalanche Energy Specified
- * Improved dv/dt Capability, High Ruggedness

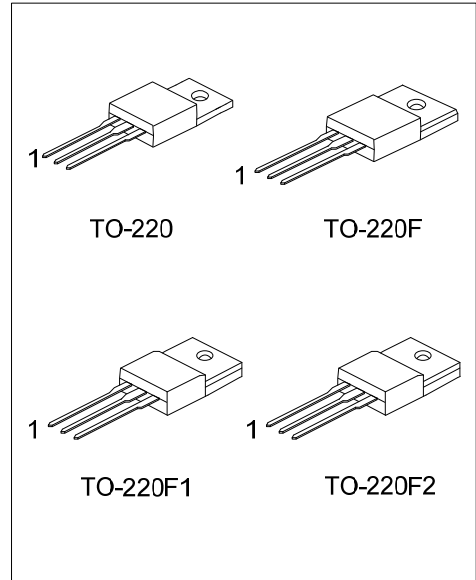

SYMBOL

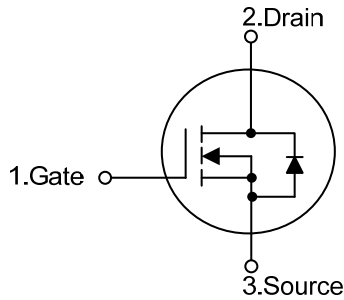

ORDERING INFORMATION

Ordering Number		Package	Pin Assignment			Packing
Lead Free	Halogen Free		1	2	3	
8N100L-TA3-T	8N100G-TA3-T	TO-220	G	D	S	Tube
8N100L-TF1-T	8N100G-TF1-T	TO-220F1	G	D	S	Tube
8N100L-TF2-T	8N100G-TF2-T	TO-220F2	G	D	S	Tube
8N100L-TF3-T	8N100G-TF3-T	TO-220F	G	D	S	Tube

Note: Pin Assignment: G: Gate D: Drain S: Source

<p>8N100G-TA3-T</p> <p>(1) Packing Type</p> <p>(2) Package Type</p> <p>(3) Green Package</p>	<p>(1) T: Tube</p> <p>(2) TA3: TO-220, TF3: TO-220F, TF1: TO-220F1, TF2: TO-220F2</p> <p>(3) G: Halogen Free and Lead Free, L: Lead Free</p>
--	--

MARKING

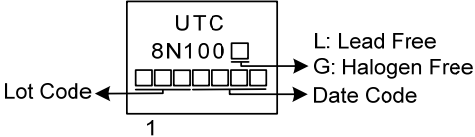

■ ABSOLUTE MAXIMUM RATINGS ($T_C = 25^\circ\text{C}$, unless otherwise specified)

PARAMETER		SYMBOL	RATINGS	UNIT
Drain-Source Voltage		V_{DSS}	1000	V
Gate-Source Voltage		V_{GSS}	± 30	V
Drain Current	Continuous	I_D	8	A
	Pulsed (Note 2)	I_{DM}	16	A
Avalanche Energy	Single Pulsed (Note 3)	E_{AS}	843	mJ
Peak Diode Recovery dv/dt (Note 4)		dv/dt	1.64	V/ns
Power Dissipation	TO-220	P_D	180	W
	TO-220F/TO-220F1		60	W
	TO-220F2			
Junction Temperature		T_J	+150	$^\circ\text{C}$
Storage Temperature		T_{STG}	-55 ~ +150	$^\circ\text{C}$

Notes: 1. Absolute maximum ratings are those values beyond which the device could be permanently damaged.

Absolute maximum ratings are stress ratings only and functional device operation is not implied.

2. Repetitive Rating : Pulse width limited by maximum junction temperature.

3. $L=60\text{mH}$, $I_{AS}=5.3\text{A}$, $V_{DD}=50\text{V}$, $R_G=25\ \Omega$, Starting $T_J = 25^\circ\text{C}$

4. $I_{SD} \leq 8.0\text{A}$, $di/dt \leq 200\text{A}/\mu\text{s}$, $V_{DD} \leq BV_{DSS}$, Starting $T_J = 25^\circ\text{C}$

■ THERMAL DATA

PARAMETER		SYMBOL	RATING	UNIT
Junction to Ambient	TO-220/TO-220F	θ_{JA}	62.5	$^\circ\text{C}/\text{W}$
	TO-220F1/TO-220F2			
Junction to Case	TO-220	θ_{JC}	0.69	$^\circ\text{C}/\text{W}$
	TO-220F/TO-220F1		2.08	$^\circ\text{C}/\text{W}$
	TO-220F2			

■ ELECTRICAL CHARACTERISTICS (T_J =25°C, unless otherwise specified)

PARAMETER	SYMBOL	TEST CONDITIONS	MIN	TYP	MAX	UNIT
OFF CHARACTERISTICS						
Drain-Source Breakdown Voltage	BV _{DSS}	V _{GS} =0V, I _D =250μA	1000			V
Drain-Source Leakage Current	I _{DSS}	V _{DS} =1000V, V _{GS} =0V			10	μA
Gate-Source Leakage Current	I _{GSS}	V _{GS} =±30V, V _{DS} =0V			±100	nA
ON CHARACTERISTICS						
Gate Threshold Voltage	V _{GS(TH)}	V _{DS} =V _{GS} , I _D =250μA	3.0		5.0	V
Static Drain-Source On-State Resistance	R _{DS(ON)}	V _{GS} =10V, I _D =4.0A			1.45	Ω
DYNAMIC CHARACTERISTICS						
Input Capacitance	C _{ISS}	V _{DS} =25V, V _{GS} =0V, f=1MHz		2165		pF
Output Capacitance	C _{OSS}			210		pF
Reverse Transfer Capacitance	C _{RSS}			30		pF
SWITCHING CHARACTERISTICS						
Total Gate Charge (Note 1)	Q _G	V _{DS} =300V, V _{GS} =10V, I _D =8A I _G =1mA (Note 1, 2)		53		nC
Gate-Source Charge	Q _{GS}			10		nC
Gate-Drain Charge	Q _{GD}			12		nC
Turn-On Delay Time (Note 1)	t _{D(ON)}	V _{DD} =400V, V _{GS} =10V, I _D =8A, R _G =25Ω (Note 1, 2)		42		ns
Turn-On Rise Time	t _R			38		ns
Turn-Off Delay Time	t _{D(OFF)}			194		ns
Turn-Off Fall Time	t _F			52		ns
SOURCE- DRAIN DIODE RATINGS AND CHARACTERISTICS						
Maximum Continuous Drain-Source Diode Forward Current	I _S				8	A
Maximum Pulsed Drain-Source Diode Forward Current	I _{SM}				16	A
Drain-Source Diode Forward Voltage (Note 1)	V _{SD}	I _S =8A, V _{GS} =0V			1.4	V
Body Diode Reverse Recovery Time (Note 1)	t _{rr}	I _S =8A, V _{GS} =0V, dI _F /dt=100A/μs		850		nS
Body Diode Reverse Recovery Charge	Q _{rr}				10.5	

Notes: 1. Pulse Test: Pulse width ≤ 300μs, Duty cycle ≤ 2%.

2. Essentially independent of operating temperature.

■ TEST CIRCUITS AND WAVEFORMS

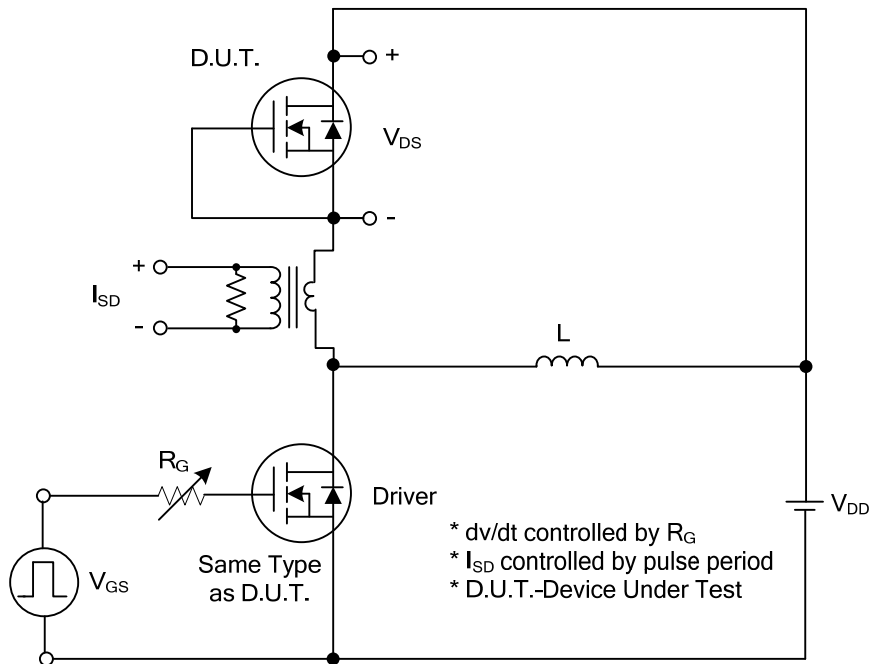

Peak Diode Recovery dv/dt Test Circuit

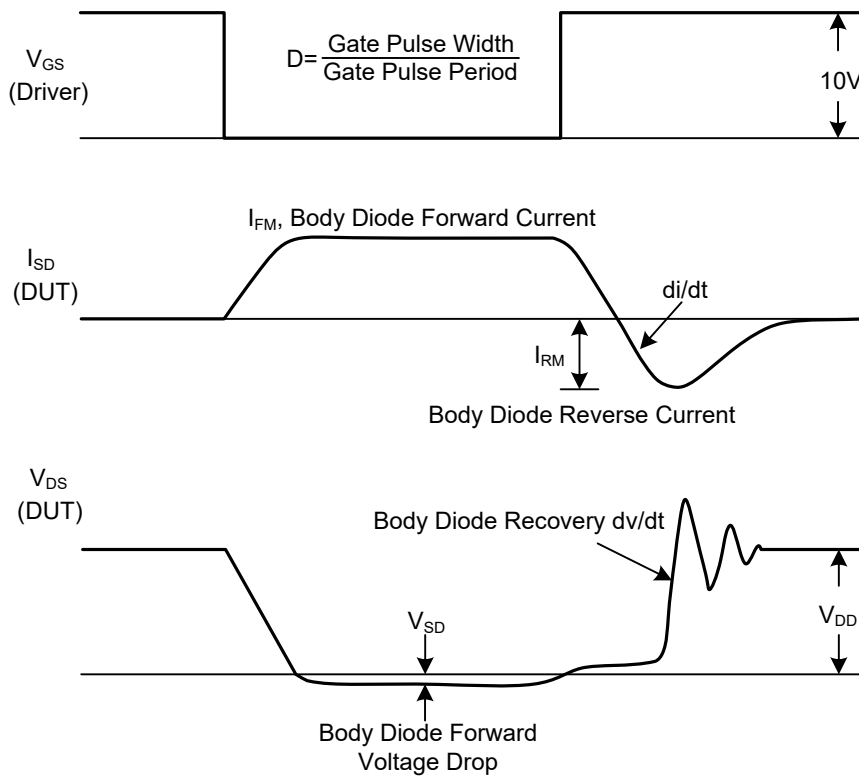

Peak Diode Recovery dv/dt Waveforms

TEST CIRCUITS AND WAVEFORMS

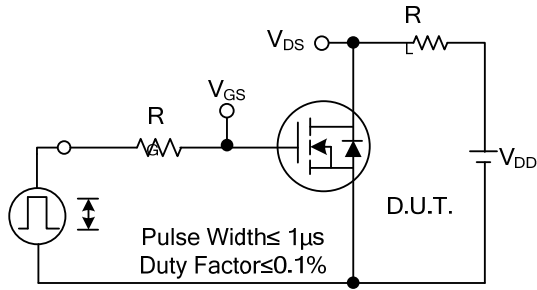

Switching Test Circuit

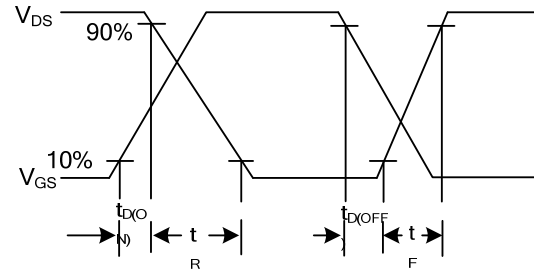

Switching Waveforms

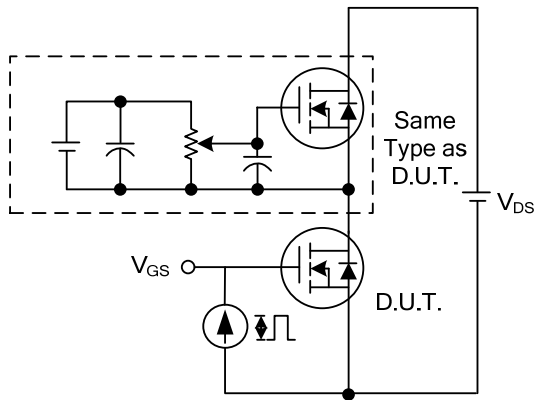

Gate Charge Test Circuit

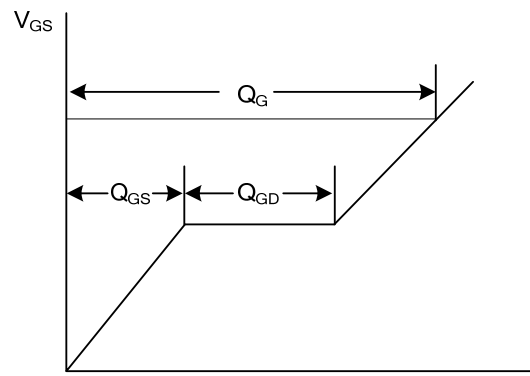

Charge

Gate Charge Waveform

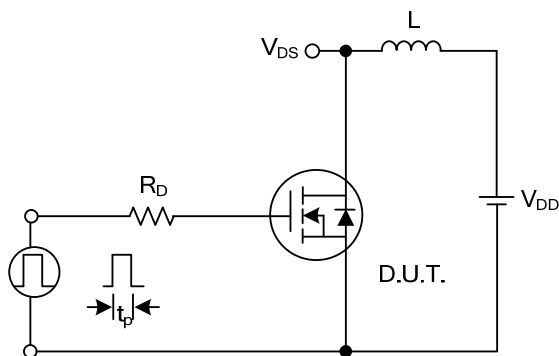

Unclamped Inductive Switching Test Circuit

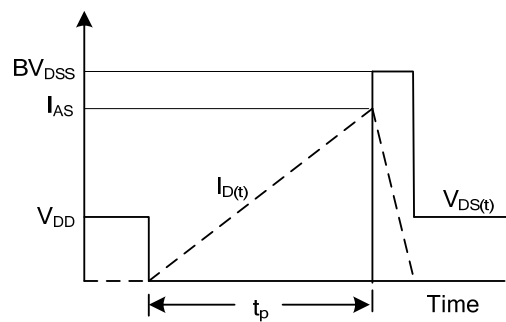

Unclamped Inductive Switching Waveforms

TYPICAL CHARACTERISTICS

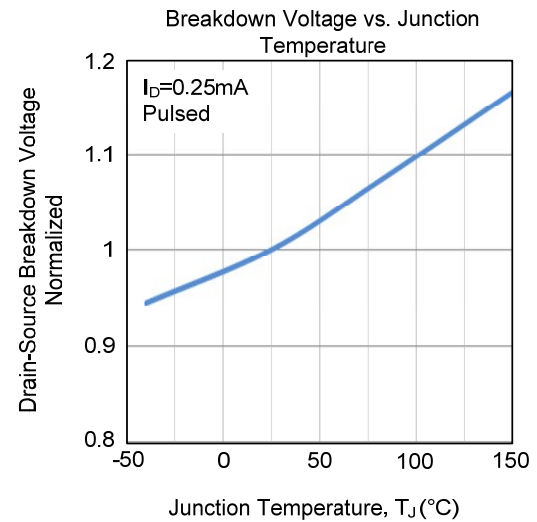
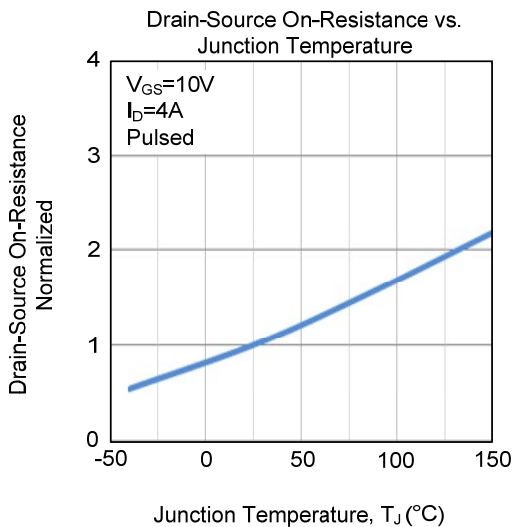
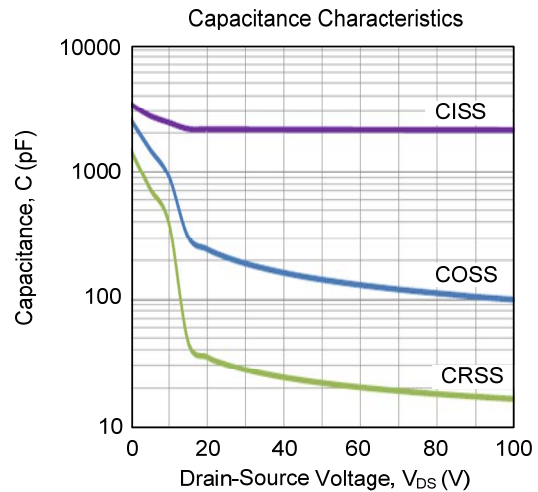
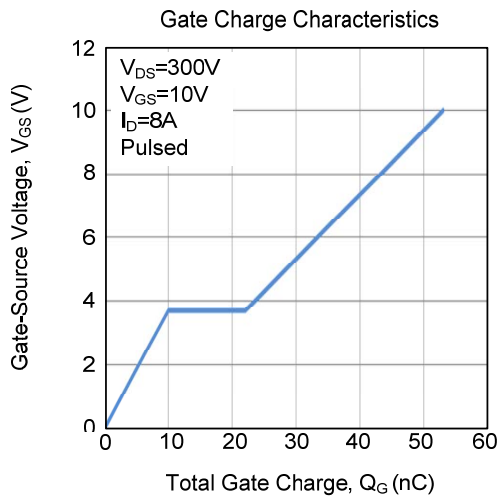
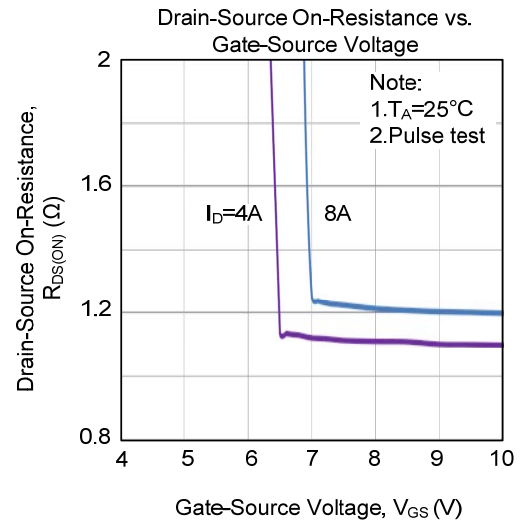
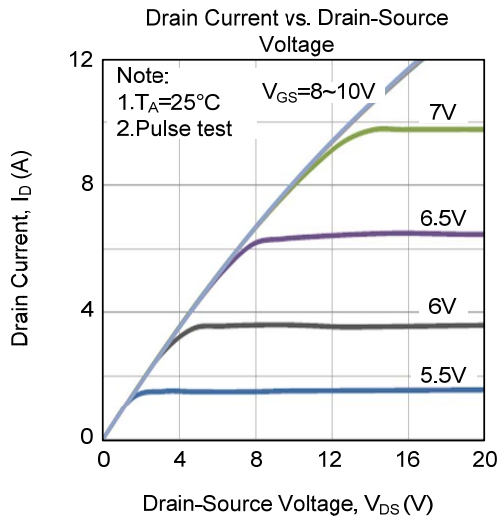

■ TYPICAL CHARACTERISTICS (Cont.)

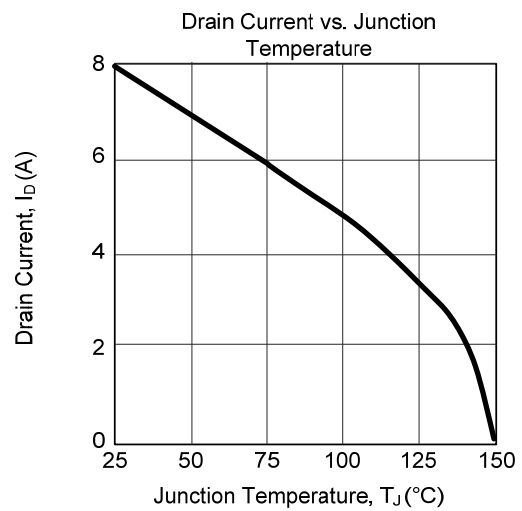
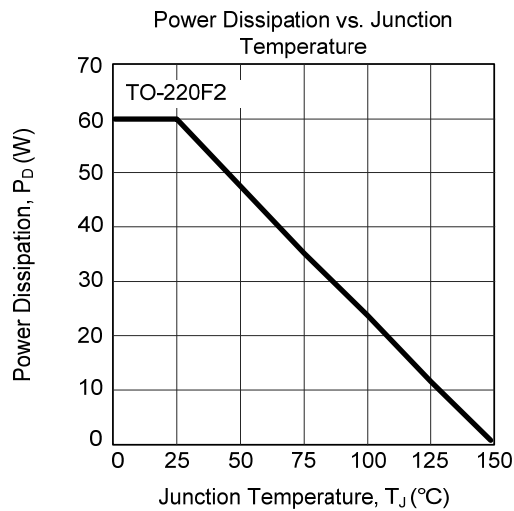
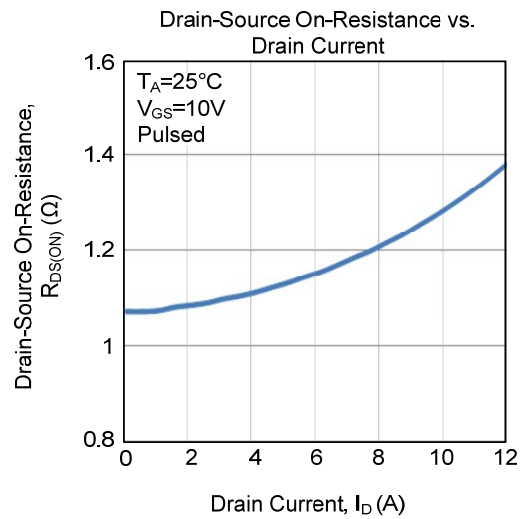
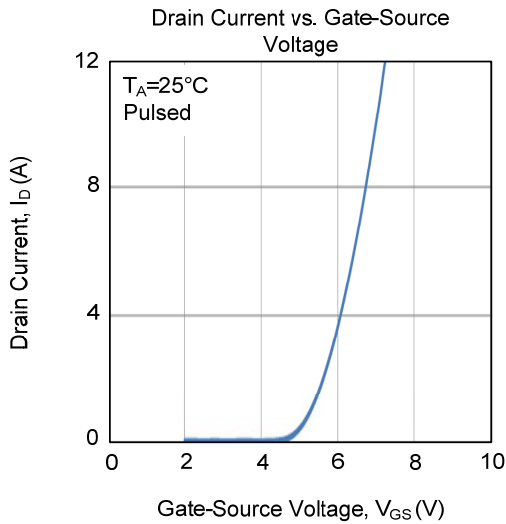
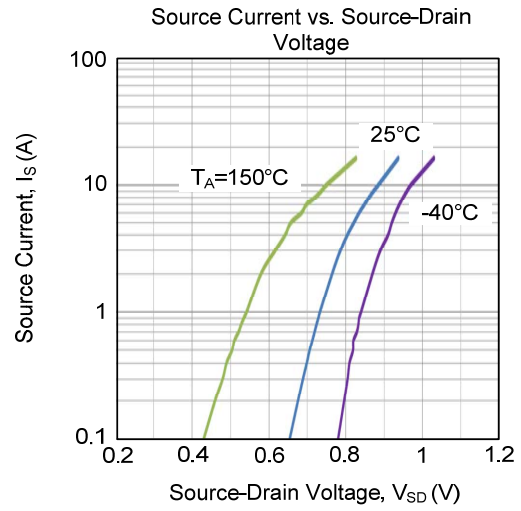
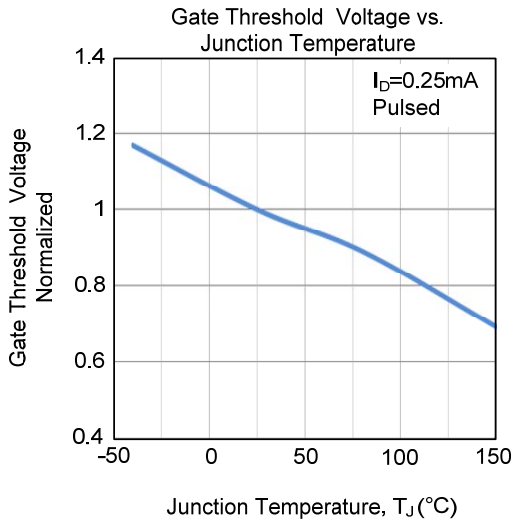

■ TYPICAL CHARACTERISTICS (Cont.)

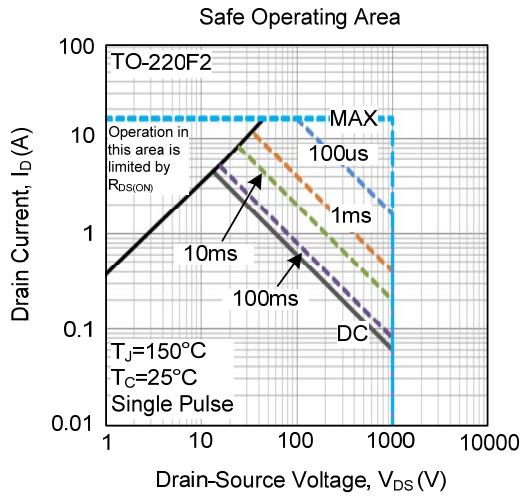

UTC assumes no responsibility for equipment failures that result from using products at values that exceed, even momentarily, rated values (such as maximum ratings, operating condition ranges, or other parameters) listed in products specifications of any and all UTC products described or contained herein. UTC products are not designed for use in life support appliances, devices or systems where malfunction of these products can be reasonably expected to result in personal injury. Reproduction in whole or in part is prohibited without the prior written consent of the copyright owner. UTC reserves the right to make changes to information published in this document, including without limitation specifications and product descriptions, at any time and without notice. This document supersedes and replaces all information supplied prior to the publication hereof.