



U74LV1T34

CMOS IC

SINGLE POWER SUPPLY SINGLE BUFFER GATE CMOS LOGIC LEVEL SHIFTER

DESCRIPTION

The **U74LV1T34** device is a low voltage CMOS gate logic that operates at a wider voltage range for industrial, portable, and telecom applications. The output level is referenced to the supply voltage and is able to support 1.8V, 2.5V, 3.3V, and 5V CMOS levels.

The input is designed with a lower threshold circuit to match 1.8 V input logic at $V_{CC}= 3.3V$ and can be used in 1.8V to 3.3V level up translation. In addition, the 5V tolerant input pins enable down translation (that is, 3.3V to 2.5V output at $V_{CC}= 2.5V$). The wide V_{CC} range of 1.8V to 5.5V allows generation of desired output levels to connect to controllers or processors.

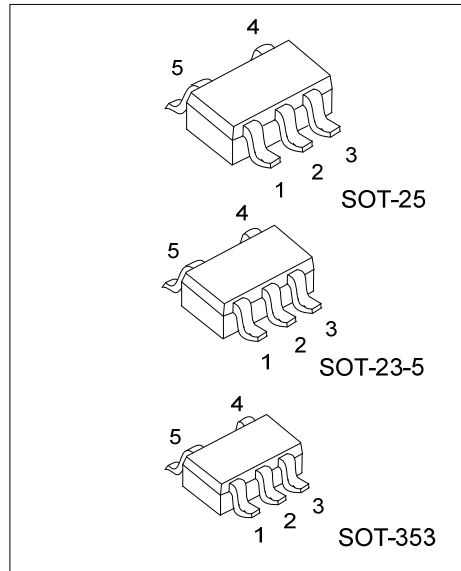

FEATURES

- * Single supply voltage translator at 1.8V, 2.5V, 3.3V and 5.0V
- * Low Power Current 1 μA (Max.)
- * $\pm 8mA$ Output Drive ($V_{CC}=5.0V$)

ORDERING INFORMATION

Ordering Number		Package	Packing
Lead Free	Halogen Free		
U74LV1T34L-AE5-R	U74LV1T34G-AE5-R	SOT-23-5	Tape Reel
U74LV1T34L-AF5-R	U74LV1T34G-AF5-R	SOT-25	Tape Reel
U74LV1T34L-AL5-R	U74LV1T34G-AL5-R	SOT-353	Tape Reel

<p>U74LV1T34G-AE5-R</p> <p>(1) Packing Type (2) Package Type (3) Green Package</p>	<p>(1) R: Tape Reel (2) AE5: SOT-23-5, AF5: SOT-25, AL5: SOT-353 (3) G: Halogen Free and Lead Free, L: Lead Free</p>
--	--

MARKING

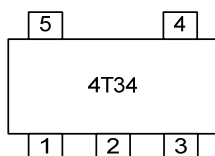

■ PIN CONFIGURATION

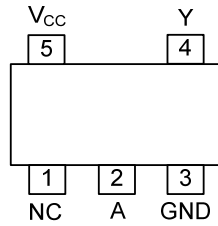

■ FUNCTION TABLE (each gate)

INPUT (Lower Level Input)	OUTPUT (V _{CC} CMOS)
A	Y
H	H
L	L

■ LOGIC DIAGRAM (positive logic)

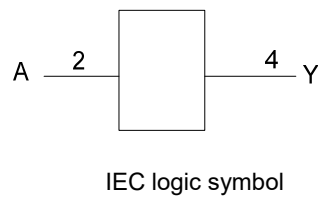
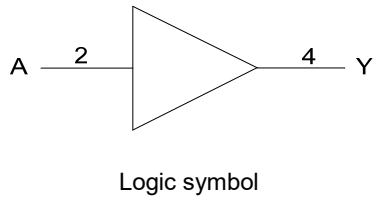

■ TYPICAL DESIGN EXAMPLES

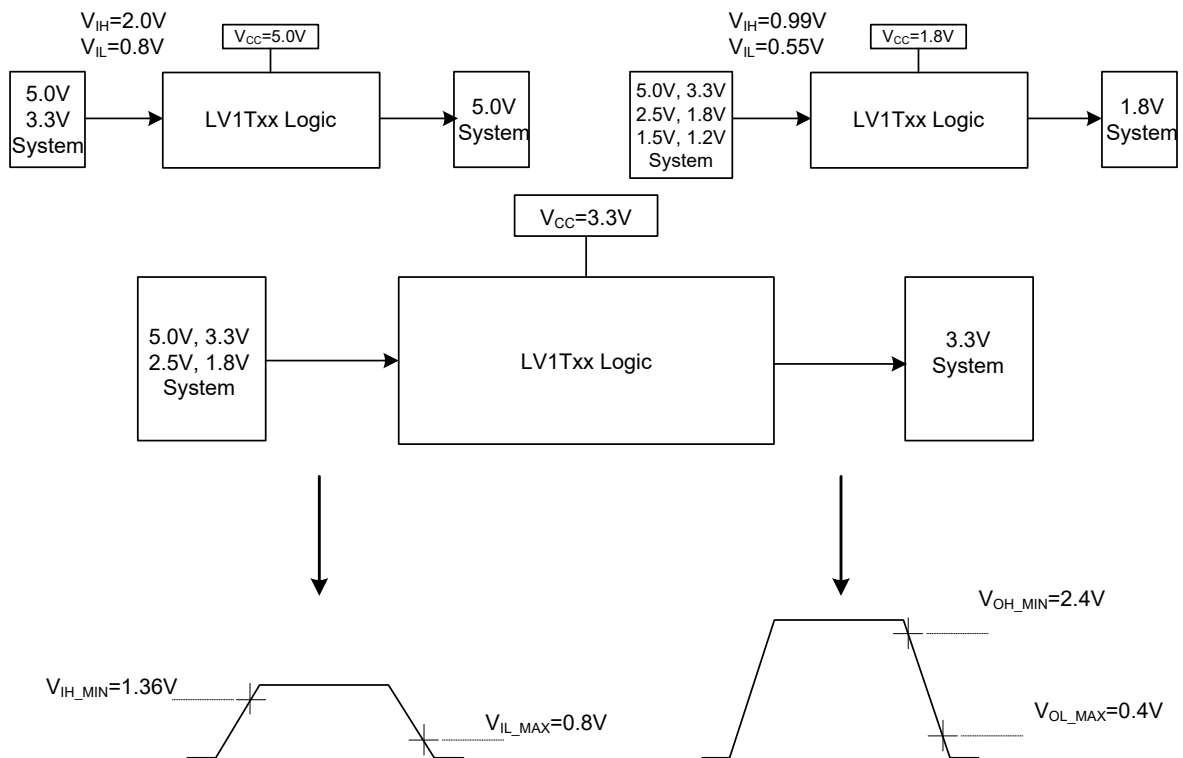

Switching Thresholds for 1.8V~3.3V Translation

■ ABSOLUTE MAXIMUM RATING (T_A=25°C, unless otherwise specified) (Note 2)

PARAMETER	SYMBOL	TEST CONDITIONS	RATINGS	UNIT
Supply Voltage	V _{CC}		-0.5 ~ 7	V
Input Voltage (Note 2)	V _{IN}		-0.5 ~ 7	V
Output Voltage (Note 2)	V _{OUT}	Output HIGH or LOW state	-0.5 ~ V _{CC} +0.5	V
		Output in power-off state	-0.5 ~ 4.6	V
Continuous Output Current	I _{OUT}		±25	mA
Continuous current through		V _{CC} or GND	±50	mA
Input Clamp Current	I _{IK}	V _{IN} <0	-20	mA
Output Clamp Current	I _{OK}	V _{OUT} <0 or V _{OUT} >V _{CC}	±20	mA
Storage Temperature Range	T _{STG}		-65 ~ +150	°C

Notes: 1. Absolute maximum ratings are those values beyond which the device could be permanently damaged. Absolute maximum ratings are stress ratings only and functional device operation is not implied.
 2. The input and output voltage ratings may be exceeded if the input and output current ratings are observed.

■ RECOMMENDED OPERATING CONDITIONS

PARAMETER	SYMBOL	TEST CONDITIONS	MIN	TYP	MAX	UNIT
Supply Voltage	V _{CC}	Operating	1.6		5.5	V
Input Voltage	V _{IN}		0		5.5	V
Output Voltage	V _{OUT}		0		V _{CC}	V
Input Transition Rise or Fall Rate	Δt/Δv	V _{CC} =1.8V			20	ns/V
		V _{CC} =3.3V or 2.5V			20	ns/V
		V _{CC} =5V			20	ns/V
Operating Temperature	T _A		-40		+125	°C

■ STATIC CHARACTERISTICS (Unless otherwise specified)

PARAMETER	SYMBOL	TEST CONDITIONS	T _A =25°C			T _A =-40~+125°C			UNIT	
			MIN	TYP	MAX	MIN	TYP	MAX		
High-Level Input Voltage	V _{IH}	V _{CC} =1.65V~1.8V	0.95			1.03			V	
		V _{CC} =2.0V	0.99			1.18			V	
		V _{CC} =2.25V~2.5V	1.145			1.18			V	
		V _{CC} =2.75V	1.22			1.25			V	
		V _{CC} =3V~3.3V	1.37			1.39			V	
		V _{CC} =3.6V	1.47			1.48			V	
		V _{CC} =4.5V~5.5V	2.02			2.03			V	
		V _{CC} =5.5V	2.1			2.11			V	
Low-Level Input Voltage	V _{IL}	V _{CC} =1.65V~2V			0.57			0.55	V	
		V _{CC} =2.25V~2.75V			0.75			0.71	V	
		V _{CC} =3V~3.6V			0.8			0.65	V	
		V _{CC} =4.5V~5.5V			0.8			0.8	V	
High-Level Output Voltage	V _{OH}	V _{CC} =1.65V ~ 5.5V, I _{OH} =-20μA	V _{CC} -0.1			V _{CC} -0.1			V	
		V _{CC} =1.65V	I _{OH} =-2mA	1.28			1.21		V	
		V _{CC} =1.8V		1.5			1.45		V	
		V _{CC} =2.3V, I _{OH} =-3mA		2			1.93		V	
		V _{CC} =2.5V, I _{OH} =-3mA		2.25			2.15		V	
		V _{CC} =3V	I _{OH} =-3mA		2.78			2.7		V
				I _{OH} =-5.5mA	2.6			2.49		V
		V _{CC} =3.3V, I _{OH} =-5.5mA		2.9			2.8		V	
		V _{CC} =4.5V	I _{OH} =-4mA		4.2			4.1		V
				I _{OH} =-8mA	4.1			3.95		V
V _{CC} =5V, I _{OH} =-8mA		4.6			4.5		V			

■ STATIC CHARACTERISTICS (Cont.)

PARAMETER	SYMBOL	TEST CONDITIONS	T _A =25°C			T _A =-40~+125°C			UNIT	
			MIN	TYP	MAX	MIN	TYP	MAX		
Low-Level Output Voltage	V _{OL}	V _{CC} =1.65V ~ 5.5V, I _{OL} =20μA			0.1			0.1	V	
		V _{CC} =1.65V, I _{OL} =2mA			0.2			0.25	V	
		V _{CC} =2.3V, I _{OL} =3mA			0.15			0.2	V	
		V _{CC} =3V	I _{OL} =3mA			0.11			0.15	V
			I _{OL} =5.5mA			0.21			0.252	V
		V _{CC} =4.5V	I _{OL} =4mA			0.15			0.2	V
I _{OL} =8mA				0.3			0.35	V		
A Input Leakage Current	I _{I(LEAK)}	V _{CC} =0V, 1.8V, 2.5V, 3.3V, 5.5V, V _{IN} =0V or V _{CC}			0.1			±1	μA	
Quiescent Supply Current	I _Q	V _{CC} =1.8V, 2.5V, 3.3V, 5V, V _{IN} =0V or V _{CC} , I _O =0; Open on loading			1			10	μA	
Additional Quiescent Supply Current	ΔI _Q	V _{CC} =5.5V, one input at 0.3V or 3.4V, other inputs at 0 or V _{CC} , I _O =0			1.35			1.5	mA	
		V _{CC} =1.8V, one input at 0.3V or 1.1V, other inputs at 0 or V _{CC} , I _O =0			10			13	μA	

■ DYNAMIC CHARACTERISTICS (Unless otherwise specified)

PARAMETER	SYMBOL	TEST CONDITIONS	T _A =25°C			T _A =-40~+125°C			UNIT	
			MIN	TYP	MAX	MIN	TYP	MAX		
Propagation delay from input (Any In) to output(Y)	t _{PLH} /t _{PHL}	C _L =15pF	V _{CC} =1.8V		10.5	13			14.3	ns
			V _{CC} =2.5V		5.8	8.5			9.7	ns
			V _{CC} =3.3V		4	7			8.2	ns
			V _{CC} =5V		2.7	6			7.1	ns
		C _L =30pF	V _{CC} =1.8V		12	14.5			15.8	ns
			V _{CC} =2.5V		6.5	9.5			10.7	ns
			V _{CC} =3.3V		4.9	8			9.2	ns
			V _{CC} =5V		3	7			8.1	ns

■ OPERATING CHARACTERISTICS (f=1MHz & 10MHz, T_A=25°C, unless otherwise specified)

PARAMETER	SYMBOL	TEST CONDITIONS	MIN	TYP	MAX	UNIT
Input Capacitance	C _{IN}	V _{CC} =3.3V, V _{IN} =V _{CC} or GND		2		pF
Output Capacitance	C _{OUT}	V _{CC} =3.3V, V _{OUT} =V _{CC} or GND		2.5		pF
Power Dissipation Capacitance	C _{PD}	V _{CC} =1.8V±0.15V		14		pF
		V _{CC} =2.5V±0.2V		14		pF
		V _{CC} =3.3V±0.3V		14		pF
		V _{CC} =5V±0.5V		14		pF

■ TEST CIRCUIT AND WAVEFORMS

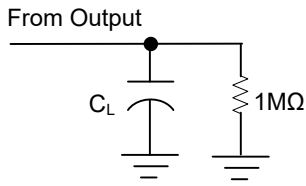

	$V_{CC}=1.8V\sim 5V$
C_L	15, 30pF
V_{MI}	$V_I/2$
V_{MO}	$V_{CC}/2$

TEST CIRCUIT

Note: C_L includes probe and jig capacitance.

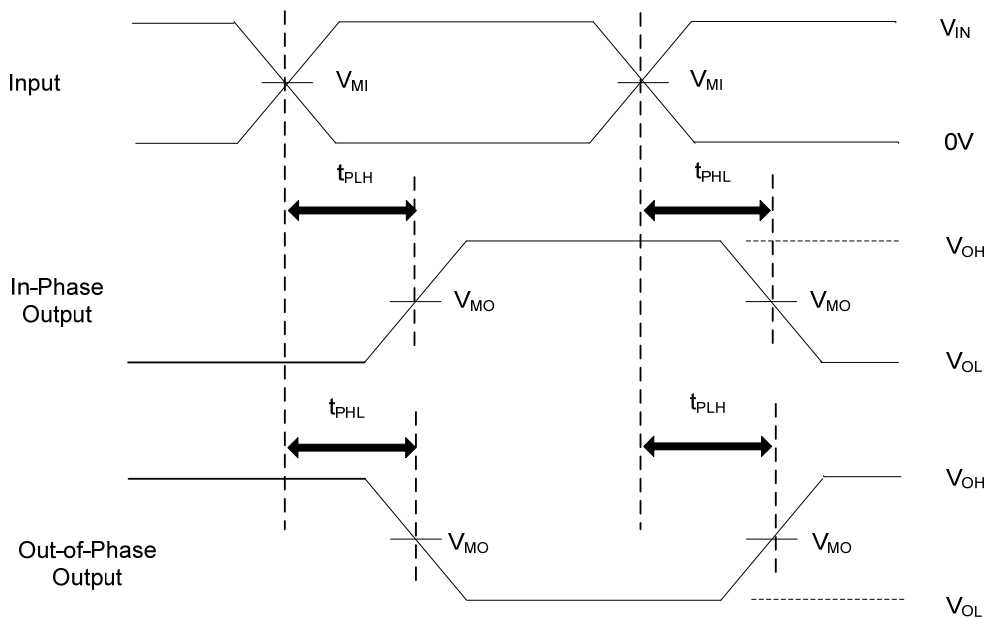

PROPAGATION DELAY TIMES

- Notes: 1. All input pulses are supplied by generators having the following characteristics: PRR \leq 1MHz, $Z_0=50\Omega$, $t_r \leq$ 3ns.
 2. The outputs are measured one at a time, with one transition per measurement.

UTC assumes no responsibility for equipment failures that result from using products at values that exceed, even momentarily, rated values (such as maximum ratings, operating condition ranges, or other parameters) listed in products specifications of any and all UTC products described or contained herein. UTC products are not designed for use in life support appliances, devices or systems where malfunction of these products can be reasonably expected to result in personal injury. Reproduction in whole or in part is prohibited without the prior written consent of the copyright owner. UTC reserves the right to make changes to information published in this document, including without limitation specifications and product descriptions, at any time and without notice. This document supersedes and replaces all information supplied prior to the publication hereof.