

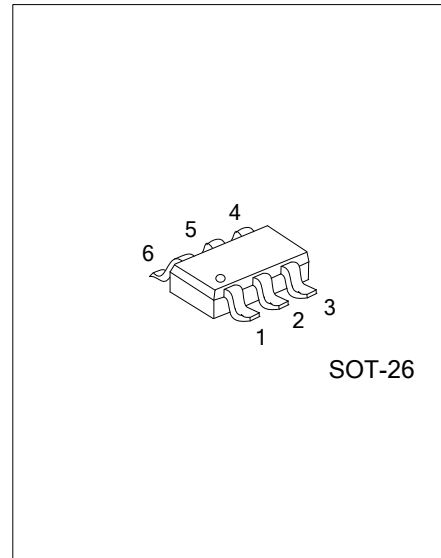

1-CH DIFFERENTIAL SENSITIVITY CALIBRATION CAPACITIVE TOUCH SENSOR



FEATURES

- * 1-Channel capacitive touch sensor with differential sensitivity calibration
- * Low power consumption
- * Uniformly adjustable sensitivity
- * Sync function for parallel operation
- * Three steps sensitivity available without external component
- * Open-drain digital output
- * Internal power on reset
- * Embedded common and normal noise elimination circuit

ORDERING INFORMATION

Ordering Number		Package	Packing
Lead Free	Halogen Free		
UCS221L-AG6-R	UCS221G-AG6-R	SOT-26	Tape Reel

Note: Pin Assignment: G: Gate D: Drain S: Source

<p>UCS221G-AG6-R</p> <ul style="list-style-type: none"> (1) Packing Type (2) Package Type (3) Green Package 	<ul style="list-style-type: none"> (1) R: Tape Reel (2) AG6: SOT-26 (3) G: Halogen Free and Lead Free, L: Lead Free
--	--

MARKING

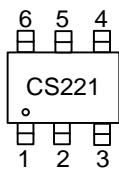

■ PIN CONFIGURATION

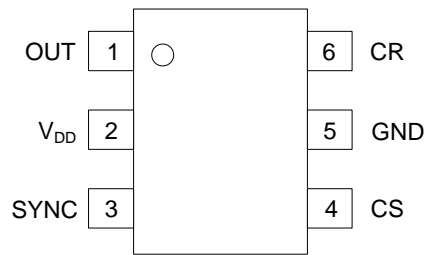

■ PIN DESCRIPTION

PIN No.	PIN NAME	Description
1	OUTPUT	Touch detect output.
2	V _{DD}	Power (2.5V ~ 5.0V).
3	SYNC	Self operation signal output Peripheral operation signal input Sensitivity selection input.
4	CS	Capacitive sensor input.
5	GND	Supply ground.
6	CR	Reference capacitive sensor input for differential sensitivity calibration.

■ ABSOLUTE MAXIMUM RATING

PARAMETER	SYMBOL	RATINGS	UNIT
Supply Voltage	V_{OUT}	5.5	V
Maximum Voltage On Any Pin	V_{IN}	$V_{DD}+0.3$	V
Maximum Current On Any PAD	V_{SHDN}	100	mA
Power Dissipation	P_D	200	mW
Junction Temperature	T_J	150	°C
Operating Temperature	T_{OPR}	-20 ~ +75	°C
Storage Temperature	T_{STG}	-50 ~ +150	°C

Note: Absolute maximum ratings are those values beyond which the device could be permanently damaged. Absolute maximum ratings are stress ratings only and functional device operation is not implied.

■ ELECTRICAL CHARACTERISTICS ($V_{DD} = 3.3V$, $T_A = 25^\circ C$, unless otherwise specified)

PARAMETER	SYMBOL	TEST CONDITIONS	MIN	TYP	MAX	UNIT
Operating Supply Voltage	V_{DD}		2.5	3.3	5	V
Current Consumption	I_{DD}	$V_{DD}=3.3V$		25	40	μA
		$V_{DD}=5.0V$		40	70	μA
Sense Input Capacitance Range (Note3)	C_S			10		pF
Reference Input Capacitance Range (Note4)	C_R			12		pF
Sense Input Resistance Range	R_S			200		Ω
Minimum Detectable Capacitance Variation	ΔC_S	$C_S=10pF$		0.2		pF
Output Impedance (Open Drain)	Z_O	$\Delta C_S > 0.2pF$		12		Ω
		$\Delta C_S < 0.2pF$		30		$M\Omega$
Self Calibration Time After V_{DD} Setting	T_{CAL}			200		ms
Maximum Supply Voltage Rising Time	T_{R_VDD}			100		ms
Recommended Sync Resistance Range	R_{SYNC}			2		$M\Omega$

Notes: 1. The sensitivity can be increased with lower C_S value. The recommended value of C_S is 10pF when using 3T PC(Poly Carbonate) cover and 10mm x 7mm touch pattern and middle sensitivity selection.

2. C_R value is recommended as same that of C_{S_TOT} as possible for effective differential sensitivity calibration. $C_{S_TOT} = C_S + C_{PARA}$ (C_{PARA} is parasitic capacitance of CS pin) If proper CR capacitor value is used, CR pin has almost same frequency as that of CS pin.

■ DETAILED DESCRIPTION

Current consumption

UCS221 uses internal bias circuit, so internal clock frequency and current consumption is not adjusted. The typical current consumption curve of UCS221 is represented in accordance with V_{DD} voltage as below. The higher V_{DD} requires more current consumption. Internal bias circuit can make the circuit design simple and reduce external components.

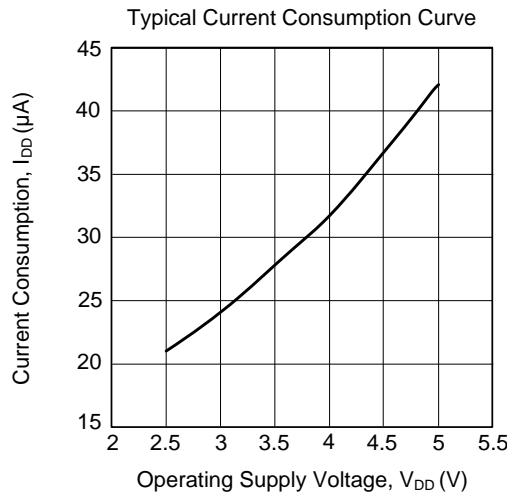

CS and CR implementation

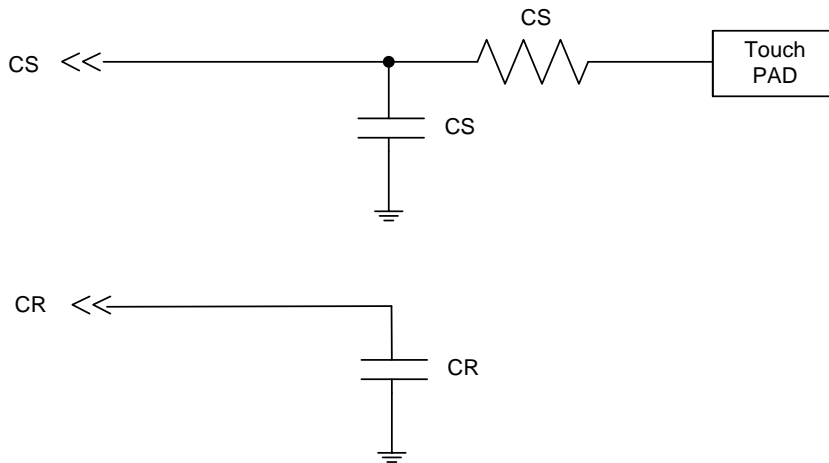

The parallel capacitor C_S is added to CS and C_R to CR to adjust fine sensitivity. The major factor of the sensitivity is C_S . The sensitivity would be increased when smaller C_S value is used. (Ref. below Sensitivity Example Figure) The C_R value should be almost the same as the total C_S capacitance (C_{S_TOT}) for effective differential sensitivity calibration. The total C_S capacitance is composed of C_S which is set for optimal sensitivity and parasitic capacitance of CS pattern (C_{PARA}). The parasitic capacitance of CS pattern is about 2pF if normal touch pattern size is used. But in the case of using larger touch pattern, C_{PARA} is bigger than normal value.

The R_S is serial connection resistor to avoid malfunction from external surge and ESD. (It might be optional.) From 200 Ω to 1k Ω is recommended for R_S . The size and shape of touch PAD might have influence on the sensitivity. The sensitivity will be optimal when the size of PAD is approximately an half of the first knuckle (it's about 10mm \times 7mm). The connection line of CS to the touch PAD is recommended to be routed as short as possible to prevent from abnormal touch detection caused by connection line.

■ TYPICAL APPLICATION CIRCUIT

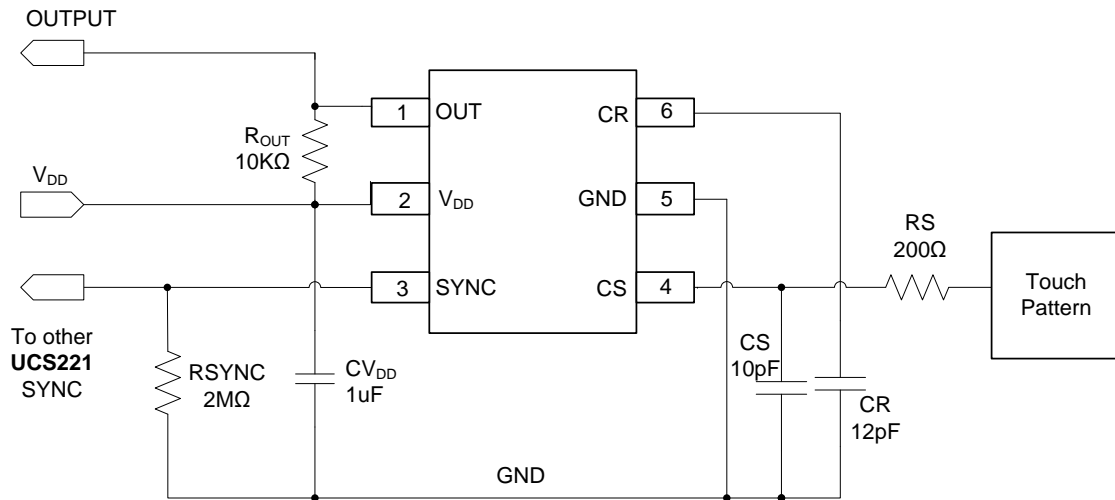

The capacitor and resistor might be connected with CS (pin4) for getting a stable sensitivity.

The capacitor value which is connected to CR pin (C_R) should be almost the same as the total CS capacitance (include parasitic capacitance) for an effective differential sensitivity calibration.

UCS221 is reset by internal reset circuit. V_{DD} voltage rising time should be shorter than 100msec for proper operation.

The sensitivity can be adjusted through a connection of SYNC pin.

From two **UCS221** to ten **UCS221** (or other TS series touch sensor) can work on the one application at the same time thanks to SYNC function.

UCS221 OUT port has an open drain structure. The pull-up resistor should therefore be needed as above figure.

V_{DD} periodic voltage ripples over 50mV or the ripple frequency which is lower than 10 kHz it can cause wrong sensitivity calibration. To prevent above problem, power (V_{DD} , GND) line of touch circuit should be separated from the other circuit. Especially the LED driver power line or digital switching circuit power line should be certainly treated to be separated from touch circuit.

The C_S pattern should be routed as short as possible and the width of the line should be around 0.25mm.

The C_S pattern routing should be formed by bottom metal (opposite metal of touch PAD).

The capacitor which is between V_{DD} and GND is an obligation. It should be placed as close as possible from **UCS221**.

The empty space of PCB must be filled with GND pattern to strengthen GND pattern and to prevent external noise that causes interference with the sensing frequency.

UTC assumes no responsibility for equipment failures that result from using products at values that exceed, even momentarily, rated values (such as maximum ratings, operating condition ranges, or other parameters) listed in products specifications of any and all UTC products described or contained herein. UTC products are not designed for use in life support appliances, devices or systems where malfunction of these products can be reasonably expected to result in personal injury. Reproduction in whole or in part is prohibited without the prior written consent of the copyright owner. UTC reserves the right to make changes to information published in this document, including without limitation specifications and product descriptions, at any time and without notice. This document supersedes and replaces all information supplied prior to the publication hereof.