



89CXX/89NXX

CMOS IC

LOW VOLTAGE FREE DELAY TIME SETTING VOLTAGE DETECTOR IC SERIES

DESCRIPTION

UTC **89CXX** and **89NXX** series are adjustable output delay Voltage Detector based on CMOS process. It is a high-accuracy, ultra-low current consumption Voltage Detector IC series with a built-in delay circuit. UTC **89CXX** and **89NXX** have two output types (Nch open drain and CMOS output) and detection voltages range from 0.9V to 4.8V in increments of 0.1V, so that the series may be selected according to application.

FEATURES

- * Adjustable delay Time
- * Ultra-low current consumption
- * Wide operating temperature range
- * **89CXX**: Push-Pull $\overline{\text{RESET}}$ Active Low Output
- * **89NXX**: Open-Drain $\overline{\text{RESET}}$ Active Low Output

ORDERING INFORMATION

Ordering Number		Package	Packing
Lead Free	Halogen Free		
89CXXL-AE5-R	89CXXG-AE5-R	SOT-23-5	Tape Reel
89CXXL-AF5-R	89CXXG-AF5-R	SOT-25	Tape Reel
89CXXL-AL4-R	89CXXG-AL4-R	SOT-343	Tape Reel
89NXXL-AE5-R	89NXXG-AE5-R	SOT-23-5	Tape Reel
89NXXL-AF5-R	89NXXG-AF5-R	SOT-25	Tape Reel
89NXXL-AL4-R	89NXXG-AL4-R	SOT-343	Tape Reel

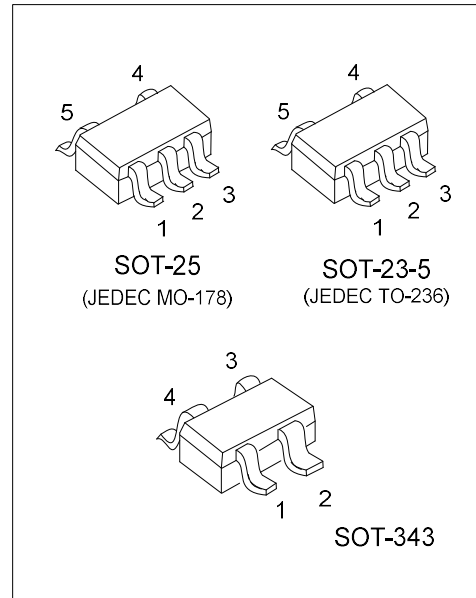

<p>89CXXG-AE5-R</p> <p>(1)Packing Type (2)Package Type (3)Green Package (4)Output Voltage (5)Output type</p>	<p>(1) R: Tape Reel (2) AE5: SOT-23-5, AF5: SOT-25, AL4: SOT-343 (3) G: Halogen Free and Lead Free, L: Lead Free (4) XX: refer to Marking Information (5) C: CMOS Output, N: Open Drain Output</p>
--	--

MARKING INFORMATION

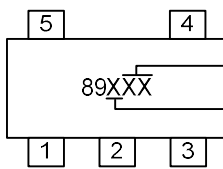
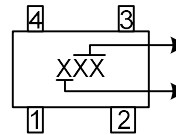
PACKAGE	VOLTAGE CODE		MARKING
SOT-23-5 SOT-25	09: 0.9V	29: 2.9V	 <p>Output Voltage C: CMOS N: Open Drain</p>
	10: 1.0V	30: 3.0V	
	11: 1.1V	31: 3.1V	
	12: 1.2V	32: 3.2V	
	13: 1.3V	33: 3.3V	
	14: 1.4V	34: 3.4V	
	15: 1.5V	35: 3.5V	
	16: 1.6V	36: 3.6V	
	17: 1.7V	37: 3.7V	
	18: 1.8V	38: 3.8V	
	19: 1.9V	39: 3.9V	
	20: 2.0V	40: 4.0V	
	21: 2.1V	41: 4.1V	
	22: 2.2V	42: 4.2V	
	23: 2.3V	43: 4.3V	
	24: 2.4V	44: 4.4V	
	25: 2.5V	45: 4.5V	
	26: 2.6V	46: 4.6V	
27: 2.7V	47: 4.7V		
28: 2.8V	48: 4.8V	 <p>Output Voltage F: CMOS D: Open Drain</p>	

PIN CONFIGURATION

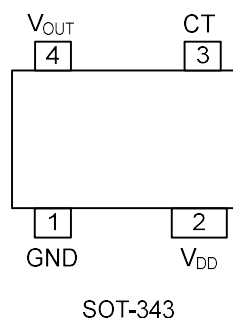
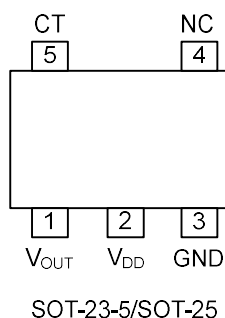

PIN DESCRIPTION

PIN NO.		PIN NAME	DESCRIPTION
SOT-23-5	SOT-343		
1	4	V _{OUT}	Reset output
2	2	V _{DD}	Power supply voltage
3	1	GND	Ground
4	-	NC	No Connect
5	3	CT	Output delay time control.(connected with capacitor)

■ BLOCK DIAGRAM

For CMOS

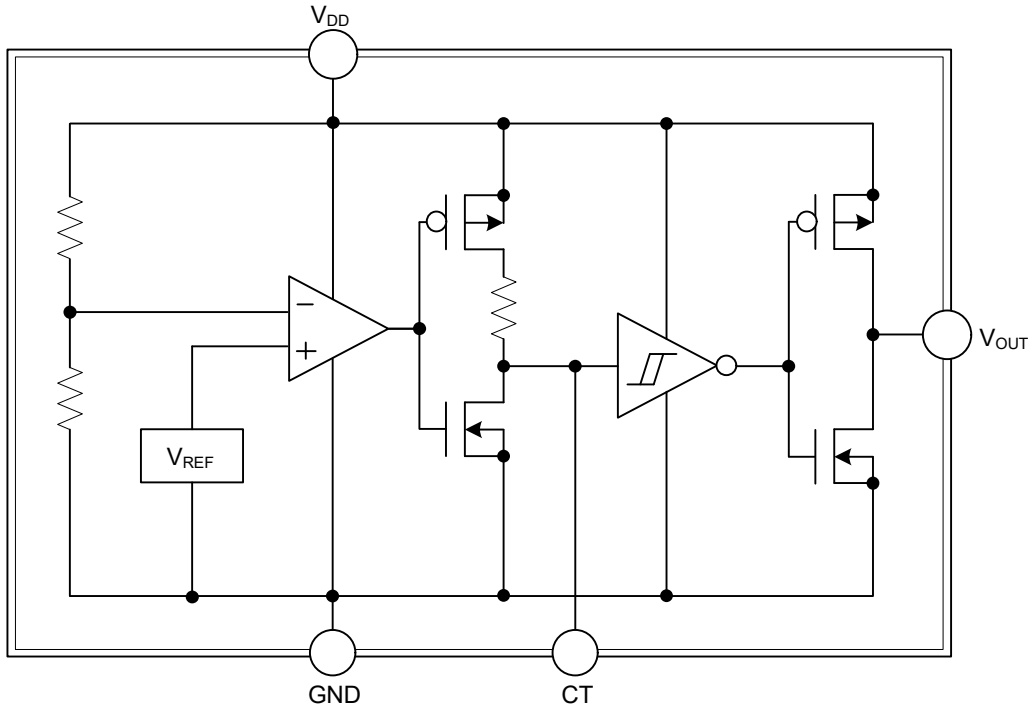

For Open Drain

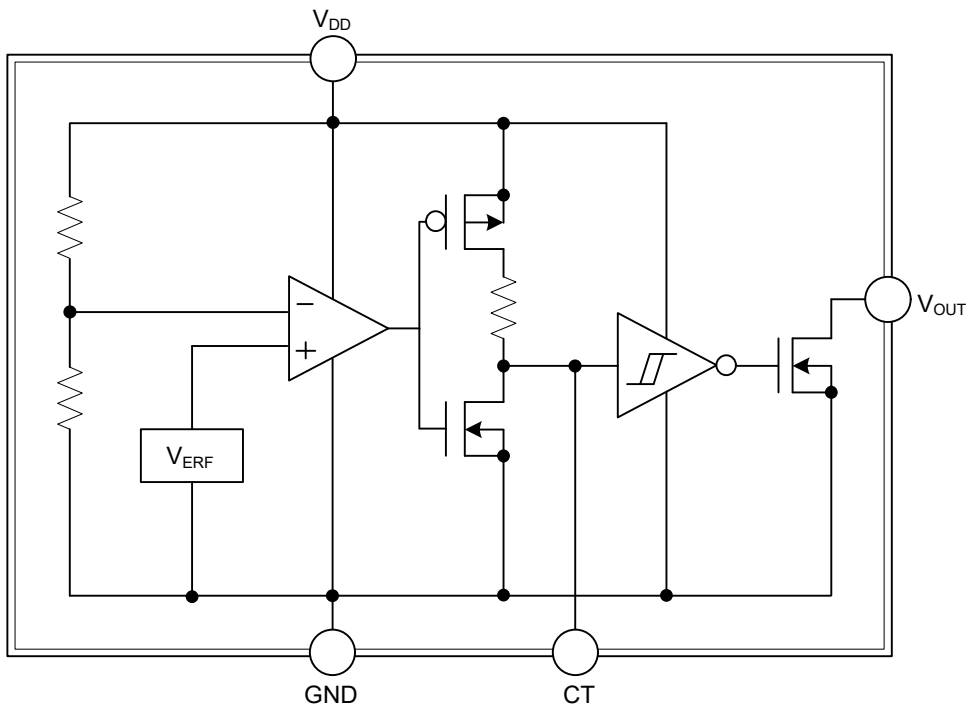

■ ABSOLUTE MAXIMUM RATING

PARAMETER		SYMBOL	RATINGS	UNIT
Power Supply Voltage		V_{DD}	-0.3 ~ +7	V
Output Voltage	Nch Open Drain Output	V_{OUT}	GND-0.3 ~ +7	V
	CMOS Output		GND-0.3 ~ $V_{DD}+0.3$	
Output Current		I_o	70	mA
Power Dissipation	SOT-343	P_D	400	mW
	SOT-23-5		540	
	SOT-25		550	
Operation Temperature Range		T_{OPT}	-40 ~ +125	°C
Ambient Storage Temperature		T_{STG}	-55 ~ +125	°C

Note: Absolute maximum ratings are those values beyond which the device could be permanently damaged. Absolute maximum ratings are stress ratings only and functional device operation is not implied.

■ ELECTRICAL CHARACTERISTICS ($T_A=-25\sim 125^\circ\text{C}$, unless otherwise specified)

PARAMETER	SYMBOL	TEST CONDITIONS	MIN	TYP	MAX	UNIT	
Detection Voltage	V_{DET}	$V_{DD}=H\rightarrow L, T_A=25^\circ\text{C}, R_L=470\text{k}\Omega$	$V_{DET}(T) \times 0.99$	$V_{DET}(T)$	$V_{DET}(T) \times 1.01$	V	
			$V_{DET}=1.8\text{V}$	$T_A=+25^\circ\text{C}$	1.782		1.8
		$V_{DET}=1.8\text{V}$	$T_A=-40^\circ\text{C}\sim+85^\circ\text{C}$	1.741			1.860
			$T_A=85^\circ\text{C}\sim+125^\circ\text{C}$	1.718			1.883
			$T_A=25^\circ\text{C}$	2.475	2.5		2.525
		$V_{DET}=2.5\text{V}$	$T_A=-40^\circ\text{C}\sim+85^\circ\text{C}$	2.418			2.584
			$T_A=85^\circ\text{C}\sim+125^\circ\text{C}$	2.386			2.615
			$T_A=25^\circ\text{C}$	2.970	3.0		3.030
		$V_{DET}=3.0\text{V}$	$T_A=-40^\circ\text{C}\sim+85^\circ\text{C}$	2.901			3.100
			$T_A=85^\circ\text{C}\sim+125^\circ\text{C}$	2.864			3.139
			$T_A=25^\circ\text{C}$	3.267	3.3		3.333
		$V_{DET}=3.3\text{V}$	$T_A=-40^\circ\text{C}\sim+85^\circ\text{C}$	3.191			3.410
			$T_A=85^\circ\text{C}\sim+125^\circ\text{C}$	3.150			3.452
			$T_A=25^\circ\text{C}$	4.158	4.2		4.242
$V_{DET}=4.2\text{V}$	$T_A=-40^\circ\text{C}\sim+85^\circ\text{C}$	4.061		4.341			
	$T_A=85^\circ\text{C}\sim+125^\circ\text{C}$	4.009		4.394			
	$T_A=25^\circ\text{C}$						
Circuit Current When ON	I_{DD1}	$V_{DD}=V_{DET}-0.2\text{V}$	$V_{DET}=0.9\sim 1.3\text{V}$	0.15	0.88	μA	
			$V_{DET}=1.4\sim 2.1\text{V}$	0.20	1.05		
			$V_{DET}=2.2\sim 2.7\text{V}$	0.25	1.23		
			$V_{DET}=2.8\sim 3.3\text{V}$	0.30	1.40		
			$V_{DET}=3.4\sim 4.2\text{V}$	0.35	1.58		
			$V_{DET}=4.3\sim 4.8\text{V}$	0.40	1.75		
Circuit Current When OFF	I_{DD2}	$V_{DD}=V_{DET}+2.0\text{V}$	$V_{DET}=0.9\sim 1.3\text{V}$	0.30	1.40	μA	
			$V_{DET}=1.4\sim 2.1\text{V}$	0.35	1.58		
			$V_{DET}=2.2\sim 2.7\text{V}$	0.40	1.75		
			$V_{DET}=2.8\sim 3.3\text{V}$	0.45	1.93		
			$V_{DET}=3.4\sim 4.2\text{V}$	0.50	2.10		
			$V_{DET}=4.3\sim 4.8\text{V}$	0.55	2.28		

ELECTRICAL CHARACTERISTICS ($T_A=-25\sim 125^\circ\text{C}$, unless otherwise specified)

PARAMETER	SYMBOL	TEST CONDITIONS	MIN	TYP	MAX	UNIT	
Operating Voltage Range	V_{OPL}	$V_{OL}\leq 0.4\text{V}$, $T_A=25\sim 125^\circ\text{C}$, $R_L=470\text{k}\Omega$	0.70			V	
		$V_{OL}\leq 0.4\text{V}$, $T_A=-40\sim 25^\circ\text{C}$, $R_L=470\text{k}\Omega$	0.90				
High Output Voltage (Pch)	V_{OH}	$V_{DD}=4.8\text{V}$, $I_{SOURCE}=1.7\text{mA}$, $V_{DET}=0.9\text{V}\sim 3.9\text{V}$	$V_{DD}-0.5$			V	
		$V_{DD}=6.0\text{V}$, $I_{SOURCE}=2.0\text{mA}$, $V_{DET}=4.0\text{V}\sim 4.8\text{V}$	$V_{DD}-0.5$				
Low Output Voltage (Nch)	V_{OL}	$V_{DD}=0.85\text{V}$, $I_{SINK}=20\mu\text{A}$			0.05	V	
		$V_{DD}=1.5\text{V}$, $I_{SINK}=1\text{mA}$, $V_{DET}=1.7\sim 4.8\text{V}$			0.5		
		$V_{DD}=2.4\text{V}$, $I_{SINK}=3.6\text{mA}$, $V_{DET}=2.7\sim 4.8\text{V}$			0.5		
Leak Current When OFF	I_{leak}	$V_{DD}=V_{DS}=7\text{V}$, $T_A=-40\sim 85^\circ\text{C}$		0	0.1	μA	
		$V_{DD}=V_{DS}=7\text{V}$, $T_A=85\sim 125^\circ\text{C}$		0	1		
CT Pin Threshold Voltage	V_{CTH}	$V_{DD}=V_{DET}\times 1.1$, $V_{DET}=0.9\sim 2.5\text{V}$, $T_A=25^\circ\text{C}$, $R_L=470\text{k}\Omega$	$V_{DD}\times 0.35$	$V_{DD}\times 0.45$	$V_{DD}\times 0.55$	V	
		$V_{DD}=V_{DET}\times 1.1$, $V_{DET}=2.6\sim 4.8\text{V}$, $T_A=25^\circ\text{C}$, $R_L=470\text{k}\Omega$	$V_{DD}\times 0.40$	$V_{DD}\times 0.50$	$V_{DD}\times 0.60$		
Output Delay Resistance	R_{CT}	$V_{DD}=V_{DET}\times 1.1$, $V_{CT}=0.5\text{V}$, $T_A=25^\circ\text{C}$ (Note 1)	5	6	7	M Ω	
Detection Voltage Temperature Coefficient	$V_{DET}/\Delta T$	$T_A=-40^\circ\text{C}\sim 125^\circ\text{C}$		± 30		ppm/ $^\circ\text{C}$	
Hysteresis Voltage	ΔV_{DET}	$V_{DD}=L\rightarrow H\rightarrow L$, $T_A=-40\sim 125^\circ\text{C}$, $R_L=470\text{k}\Omega$	$V_{DET}\leq 1.0\text{V}$	$V_{DET}\times 0.03$	$V_{DET}\times 0.05$	$V_{DET}\times 0.08$	V
			$V_{DET}\geq 1.1\text{V}$	$V_{DET}\times 0.03$	$V_{DET}\times 0.05$	$V_{DET}\times 0.07$	

Note: Design Guarantee. (Outgoing inspection is not done on all products.)

$V_{DET}(T)$: Standard Detection Voltage (0.9V~4.8V, 0.1V step)

R_L : Pull-up resistor to be connected between V_{OUT} and power supply.

■ TYPICAL APPLICATION CIRCUIT

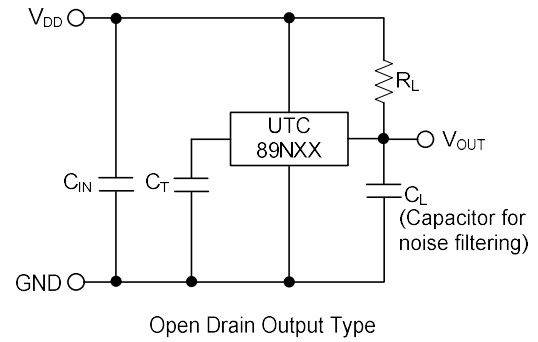
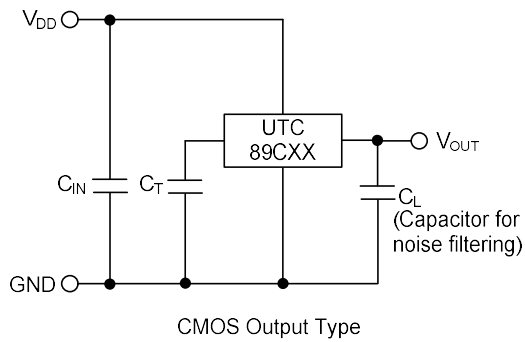

■ APPLICATION INFORMATION

Setting of detector delay time

The delay time of UTC 89CXX/89NXX can be set by the capacitor between CT and GND pin.

Use Equation (1) to set the delay time:

$$T_{PLH} = C_{CT} \times R_{CT} \times \ln \left(\frac{V_{DD}}{V_{DD} - V_{CTH}} \right) \quad (1)$$

C_{CT} : CT pin externally attached capacitance;

R_{CT} : CT pin internal impedance;

V_{CTH} : CT pin threshold voltage;

■ TYPICAL CHARACTERISTICS (Cont.)

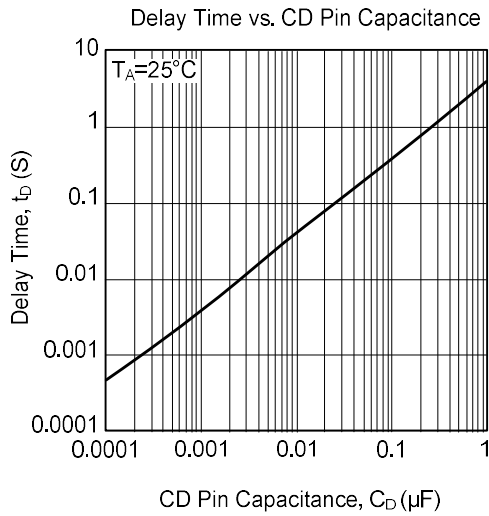

UTC assumes no responsibility for equipment failures that result from using products at values that exceed, even momentarily, rated values (such as maximum ratings, operating condition ranges, or other parameters) listed in products specifications of any and all UTC products described or contained herein. UTC products are not designed for use in life support appliances, devices or systems where malfunction of these products can be reasonably expected to result in personal injury. Reproduction in whole or in part is prohibited without the prior written consent of the copyright owner. UTC reserves the right to make changes to information published in this document, including without limitation specifications and product descriptions, at any time and without notice. This document supersedes and replaces all information supplied prior to the publication hereof.