



UL23EA

Preliminary

CMOS IC

HIGH ACCURACY LINEAR CONSTANT CURRENT LED DRIVER

DESCRIPTION

The **UL23EA** is a linear constant current IC that supports the adjust brightness or color temperature in 3 grades. The application scheme is simple and the cost is low.

In the dimming application of **UL23EA**, user can change the size of the output current by turn on/off the power switch, that adjust brightness of LED lights. Changing the REXT external resistance adjustment of brightness ratio.

In the adjust color temperature application of **UL23EA**, user can change the state of the two output ports by turn on/off the power switch, that adjust the color temperature through the light of two different colored LED lights. Changing the REXT external resistance can adjustment the output power.

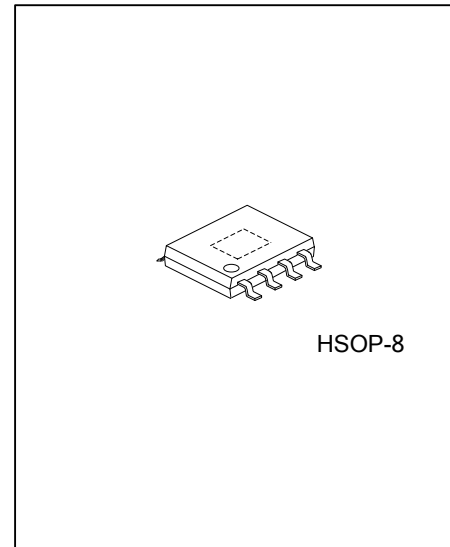

HSOP-8

FEATURES

- * Input voltage 220VAC, 110VAC
- * Adjustable output current, max 60mA
- * Inter-chip current deviation $\lt; \pm 4\%$
- * Application system no EMI problems
- * Over temperature Reduced Current
- * Supports the adjust brightness in 3 grades
- * Supports the adjust color temperature in 3 grades
- * In no stroboscopic apply:
 - Power factor > 0.5
- * No transformer and high voltage electrolysis capacitor:
 - Power factor > 0.9
- * Effectively switching time from 0.3S ~ 3S

ORDERING INFORMATION

Ordering Number		Package	Packing
Lead Free	Halogen Free		
UL23EAL-SH2-R	UL23EAG-SH2-R	HSOP-8	Tape Reel

<p>UL23EAG-SH2-R</p> <ul style="list-style-type: none"> (1)Packing Type (2)Package Type (3)Green Package 	<ul style="list-style-type: none"> (1) R: Tape Reel (2) SH2: HSOP-8 (3) G: Halogen Free and Lead Free, L: Lead Free
---	--

■ MARKING

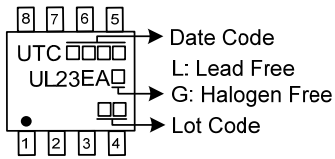

■ PIN CONFIGURATION

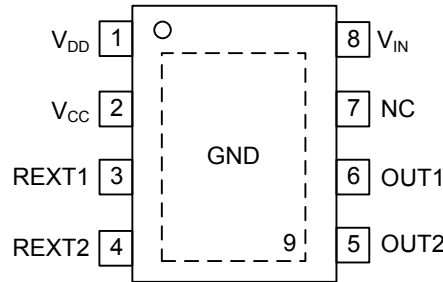

■ PIN DESCRIPTION

PIN NO.	PIN NAME	DESCRIPTION
1	V _{DD}	Analog circuit power port
2	V _{CC}	Digital circuit power port
3	REXT1	Output Current Setting Pin 1.
4	REXT2	Output Current Setting Pin 2.
5	OUT2	Constant flow output port 2
6	OUT1	Constant flow output port 1
7	NC	No connect
8	V _{IN}	Power input port
9	GND	Ground

■ ABSOLUTE MAXIMUM RATING

PARAMETER	SYMBOL	RATINGS	UNIT
OUT Pin Voltage	V_{OUT1}/V_{OUT2}	-0.5 ~ 500	V
OUT Pin Current	I_{OUT}	5 ~ 60	mA
V_{IN} Pin Voltage	V_{IN}	-0.5 ~ 500	V
REXT Pin Voltage	V_{REXT1}/V_{REXT2}	-0.5 ~ 8	V
V_{DD} Pin Voltage	V_{VDD}	-0.5 ~ 8	V
V_{CC} Pin Voltage	V_{VCC}	-0.5 ~ 8	V
Working temperature	T_{OPR}	-40 ~ +150	°C
Storage temperature	T_{STQ}	-50 ~ +150	°C

Note: Absolute maximum ratings are those values beyond which the device could be permanently damaged.

Absolute maximum ratings are stress ratings only and functional device operation is not implied.

■ ELECTRICAL CHARACTERISTICS

PARAMETER	SYMBOL	TEST CONDITIONS	MIN	TYP	MAX	UNIT
Power of IC Pin Voltage	V_{DD}/V_{CC}			6.8		V
OUT Pin Voltage	V_{OUT1}/V_{OUT2}	$I_{OUT}=30mA$	1			V
OUT Pin Withstanding Voltage	V_{DS-BV}	$I_{OUT}=0$	500			V
Output Current	I_{OUT1}/I_{OUT2}		5		120	mA
Quiescent Current	I_Q	$V_{OUT}=10V$ REXT No Collection		0.16	0.25	mA
REXT Pin Voltage	V_{REXT1}/V_{REXT2}	$V_{IN}=20V, V_{OUT1}=V_{OUT2}=10V$		0.6/0.3		V
Output Current Accuracy	D_{IOUT}	$I_{OUT}=5\sim 60mA$		± 4		%
Temperature Compensate Point	T_{SC}			130		°C

■ TYPICAL APPLICATION CIRCUIT

The **UL23EA** is a linear constant current IC that supports the adjust brightness or color temperature in 3 grades. The output current can be adjusted from 5mA to 120mA, and constant current accuracy up to $\pm 4\%$.

Plan1/Plan2 adjust brightness mode application of **UL23EA**, User can change the size of the output current by turn on/off the power switch, that adjust brightness of LED lights. Changing the REXT external resistance Adjustment of brightness ratio from X% - 50% - 100%.

Open the switch for the 1st time, during constant current: $I1 = \frac{0.6}{R_{REXT1} + R_{REXT2}}$

Open the switch for the 2nd time, during constant current: $I2 = \frac{0.3}{R_{REXT2}}$

Open the switch for the 3rd time, during constant current: $I3 = \frac{0.6}{R_{REXT2}}$

The dimming ratio is X%, 50%, 100%, $X\% = \frac{R_{REXT2}}{R_{REXT1} + R_{REXT2}}$

Plan 3/Plan 4 adjust brightness mode application of **UL23EA**, User can change the size of the output current by turn on/off the power switch, that adjust brightness of LED lights. Changing the REXT external resistance Adjustment of brightness ratio from 100% - 50% - X%.

Open the switch for the 1st time, during constant current: $I1 = \frac{0.6}{R_{REXT2}}$

Open the switch for the 2nd time, during constant current: $I2 = \frac{0.3}{R_{REXT2}}$

Open the switch for the 3rd time, during constant current: $I3 = \frac{0.6}{R_{REXT1} + R_{REXT2}}$

The dimming ratio is X%, 50%, 100%, $X\% = \frac{R_{REXT2}}{R_{REXT1} + R_{REXT2}}$

Plan 5/Plan 6 adjust color temperature application of **UL23EA**, User can change the state of the two output ports by turn on/off the power switch, that adjust the color temperature through the light of two different colored LED lights. Changing the REXT external resistance can adjustment the output power.

Open the switch for the 1st time, during constant current: $I1 = \frac{0.6}{R_{REXT2}}$

Open the switch for the 2nd time, during constant current: $I2 = \frac{0.3}{R_{REXT1}} + \frac{0.3}{R_{REXT2}}$

Open the switch for the 3rd time, during constant current: $I3 = \frac{0.6}{R_{REXT1}}$

■ TYPICAL APPLICATION CIRCUIT

1. High PF of Adjust Brightness Application

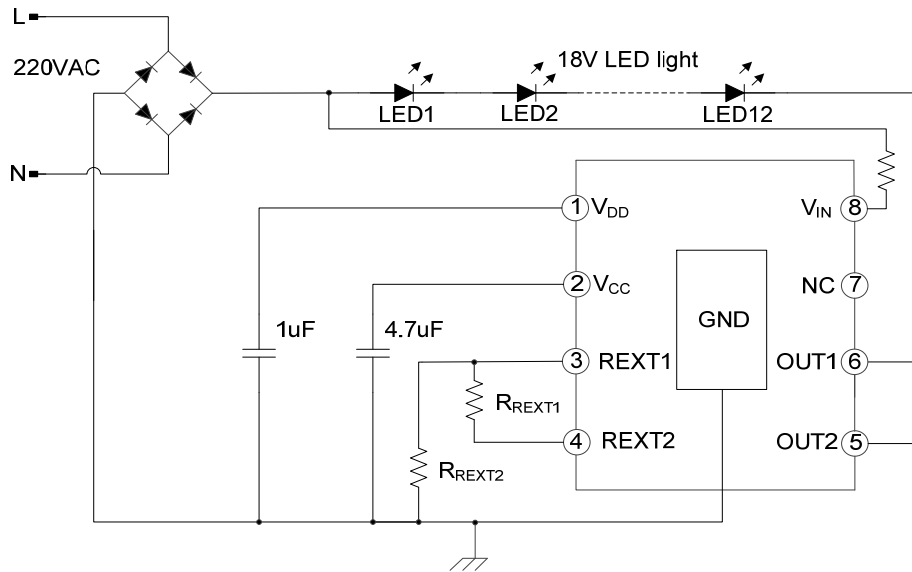

High PF of Adjust Brightness Mode

Typical Applications: $R_{REXT1}=90\Omega$, $R_{REXT2}=10\Omega$, $0.3S < \text{Switching Period} < 3S$
 Open the switch for the 1st time, $I_{OUT}=3mA$;
 Open the switch for the 2nd time, $I_{OUT}=15mA$;
 Open the switch for the 3rd time, $I_{OUT}=30mA$;
 The dimming ratio is 10%, 50%, 100%
 When the switching period $> 3S$, System reset.

■ TYPICAL APPLICATION CIRCUIT (Cont.)

2. No Stroboscopic of Adjust Brightness Application

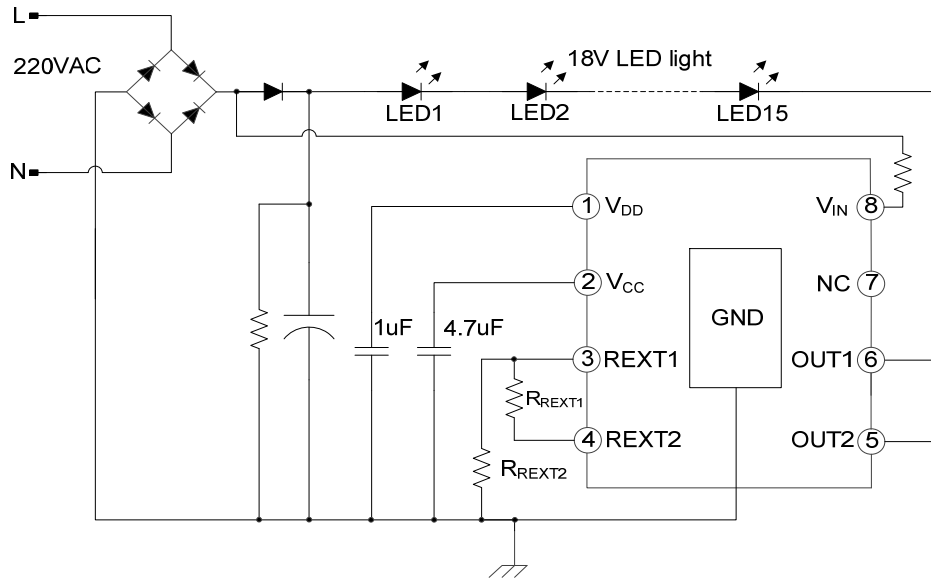

No Stroboscopic of Adjust Brightness Application

Typical Applications: $R_{REXT1}=180\Omega$, $R_{REXT2}=20\Omega$, $0.3S < \text{Switching Period} < 3S$
 Open the switch for the 1st time, $I_{OUT}=3mA$;
 Open the switch for the 2nd time, $I_{OUT}=15mA$;
 Open the switch for the 3rd time, $I_{OUT}=30mA$;
 The dimming ratio is 10%, 50%, 100%
 When the switching period $> 3S$, System reset.

■ TYPICAL APPLICATION CIRCUIT (Cont.)

3. High PF of Adjust Brightness Application

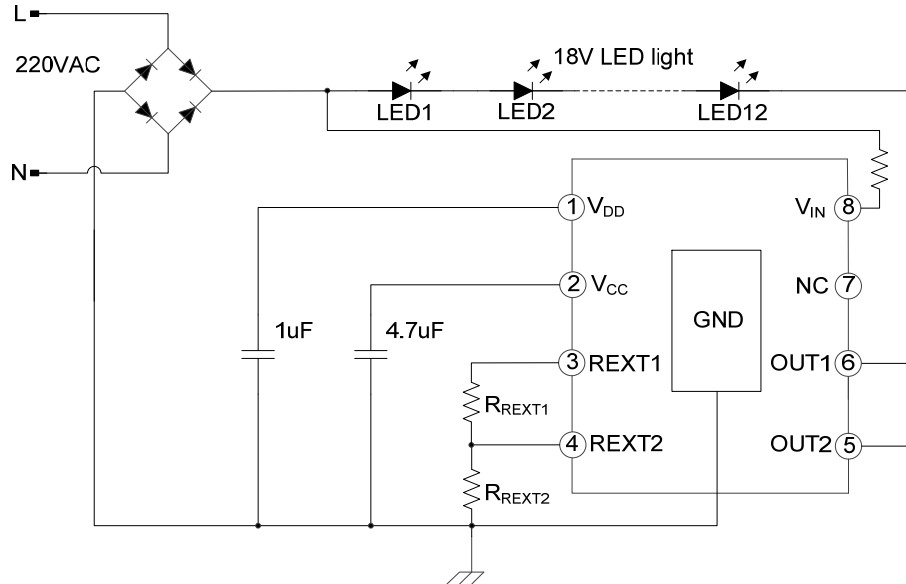

High PF of Adjust Brightness Application

Typical Applications: $R_{REXT1}=90\Omega$, $R_{REXT2}=10\Omega$, $0.3S < \text{Switching Period} < 3S$
 Open the switch for the 1st time, $I_{OUT}=30mA$;
 Open the switch for the 2nd time, $I_{OUT}=15mA$;
 Open the switch for the 3rd time, $I_{OUT}=3mA$;
 The dimming ratio is 100%, 50%, 10%
 When the switching period $> 3S$, System reset.

■ TYPICAL APPLICATION CIRCUIT (Cont.)

4. No Stroboscopic of Adjust Brightness Application

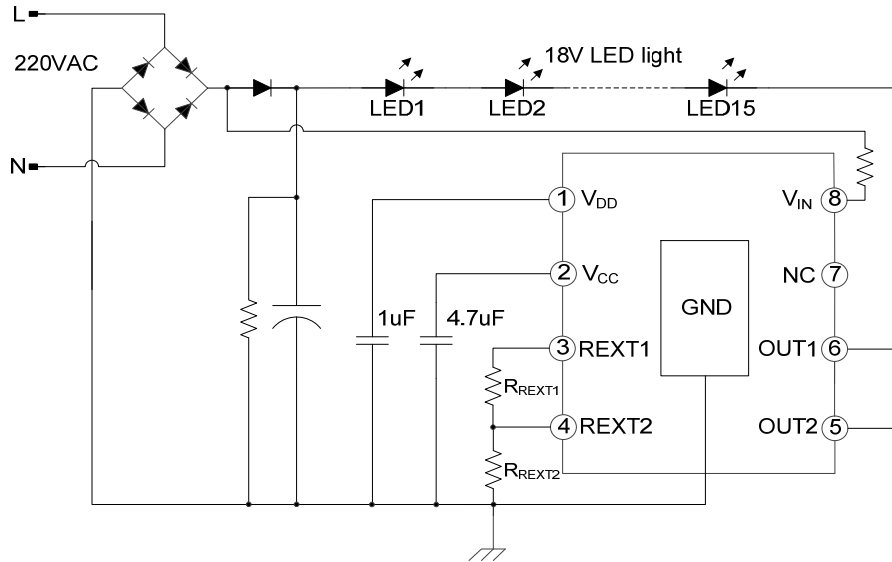

No Stroboscopic Of Adjust Brightness Application

Typical Applications: $R_{REXT1}=180\Omega$, $R_{REXT2}=20\Omega$, $0.3S < \text{Switching Period} < 3S$

Open the switch for the 1st time, $I_{OUT}=30mA$;

Open the switch for the 2nd time, $I_{OUT}=15mA$;

Open the switch for the 3rd time, $I_{OUT}=3mA$;

The dimming ratio is 100%, 50%, 10%

When the switching period $> 3S$, System reset.

■ TYPICAL APPLICATION CIRCUIT (Cont.)

5. High PF of adjust color temperature application

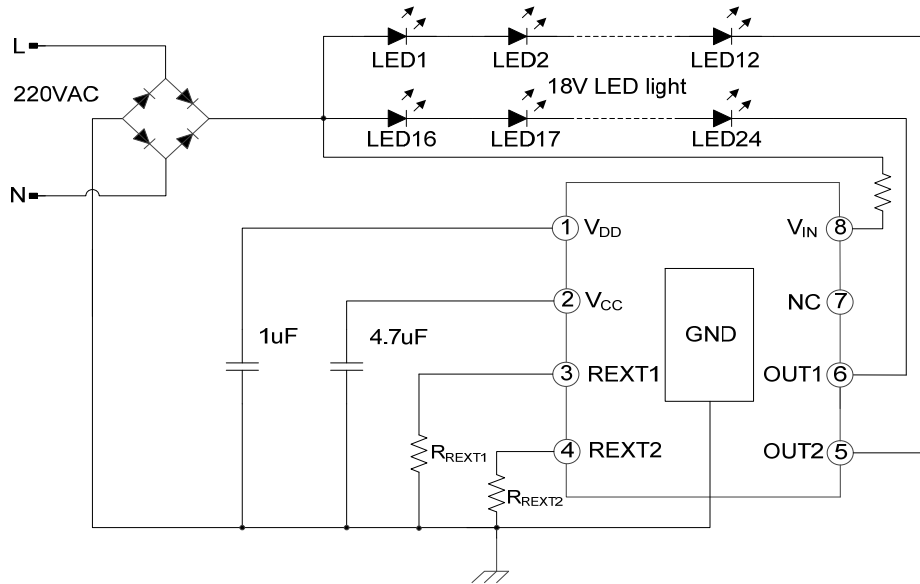

High PF of Adjust Color Temperature Mode

Typical Applications: $R_{REXT1}=R_{REXT2}=10\Omega$, $0.3S < \text{Switching Period} < 3S$
 Open the switch for the 1st time, $I_{OUT2}=30mA$;
 Open the switch for the 2nd time, $I_{OUT1}=I_{OUT2}=15mA$;
 Open the switch for the 3rd time, $I_{OUT1}=30mA$;
 When the switching period $> 3S$, System reset.

■ TYPICAL APPLICATION CIRCUIT (Cont.)

6. No stroboscopic of adjust brightness application

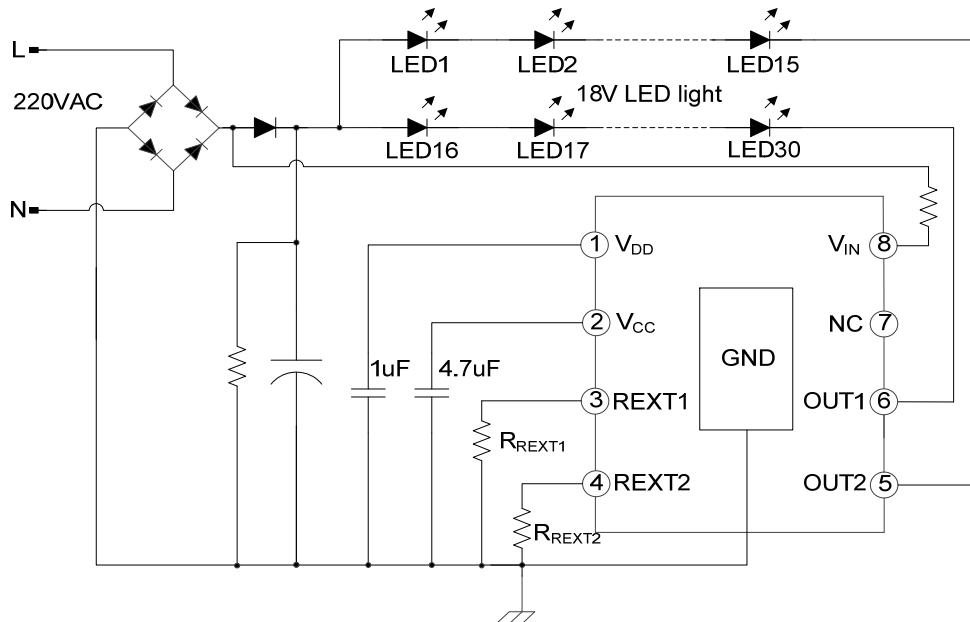

No Stroboscopic Of Adjust Color Temperature Application

Typical Applications: $R_{REXT1}=R_{REXT2}=20\Omega$, $0.3S < \text{Switching Period} < 3S$
 Open the switch for the 1st time, $I_{OUT2}=30mA$;
 Open the switch for the 2nd time, $I_{OUT1}=I_{OUT2}=15mA$;
 Open the switch for the 3rd time, $I_{OUT2}=30mA$;
 The dimming ratio is 100%, 50%, 10%
 When the switching period $> 3S$, System reset.

■ MULTIPLE IC PARALLEL SCHEMES

UL23EA support multiple IC parallel schemes, High PF of adjust brightness application as shown in the figure .If the output power is too large that the IC over temperature, Multiple IC parallel schemes can be adopted.

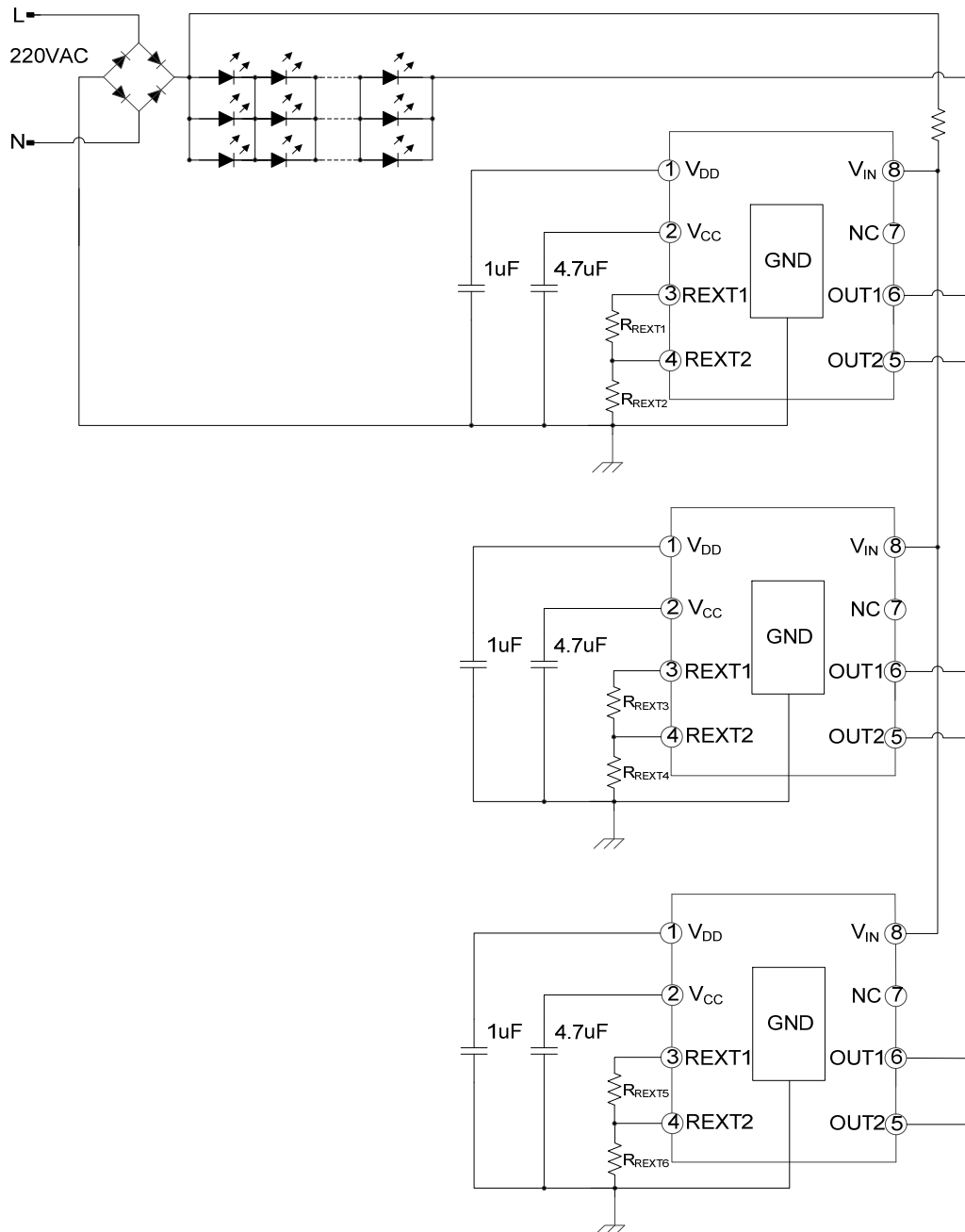

Typical Applications: $R_{REXT1}=R_{REXT3}=R_{REXT5}=90\Omega$, $R_{REXT2}=R_{REXT4}=R_{REXT6}=10\Omega$,
 $0.3S < \text{Switching Period} < 3S$;
 Open the switch for the 1st time, $I_{OUT}=90mA$;
 Open the switch for the 2nd time, $I_{OUT}=45mA$;
 Open the switch for the 3rd time, $I_{OUT}=9mA$;
 The dimming ratio is 100%, 50%, 10%
 When the switching period $> 3S$, System reset.

■ MULTIPLE IC PARALLEL SCHEMES (Cont.)

UL23EA support multiple IC parallel schemes. No stroboscopic of color temperature application as shown in the figure .If the output power is too large that the IC over temperature, Multiple IC parallel schemes can be adopted.

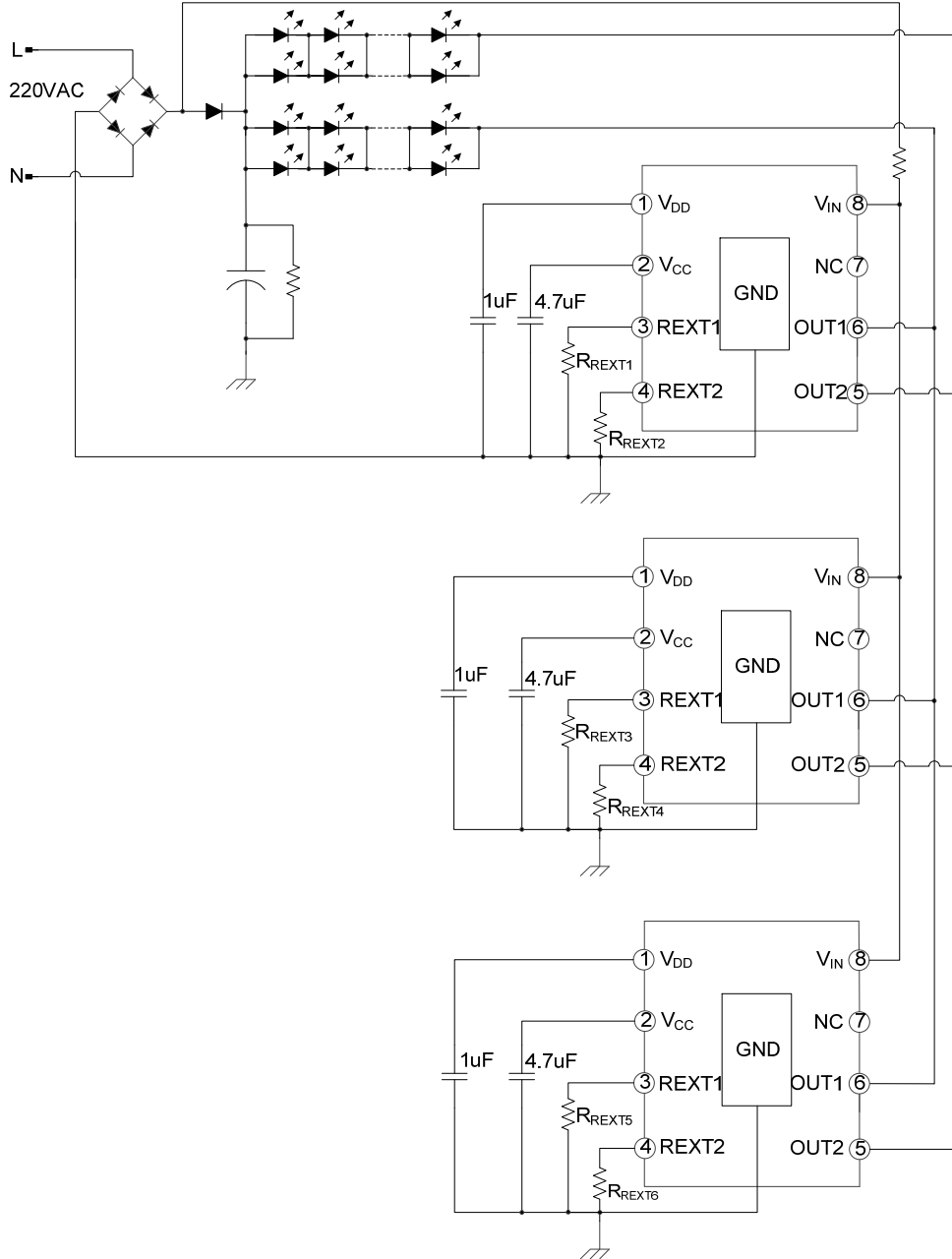

Typical Applications: $R_{REXT1}=R_{REXT3}=R_{REXT5}=20\Omega$, $R_{REXT2}=R_{REXT4}=R_{REXT6}=20\Omega$,
 $0.3S < \text{Switching Period} < 3S$;
 Open the switch for the 1st time, $I_{OUT2}=90mA$;
 Open the switch for the 2nd time, $I_{OUT1}= I_{OUT2}=45mA$;
 Open the switch for the 3rd time, $I_{OUT1}=90mA$;
 When the switching period $> 3S$, System reset.

UTC assumes no responsibility for equipment failures that result from using products at values that exceed, even momentarily, rated values (such as maximum ratings, operating condition ranges, or other parameters) listed in products specifications of any and all UTC products described or contained herein. UTC products are not designed for use in life support appliances, devices or systems where malfunction of these products can be reasonably expected to result in personal injury. Reproduction in whole or in part is prohibited without the prior written consent of the copyright owner. UTC reserves the right to make changes to information published in this document, including without limitation specifications and product descriptions, at any time and without notice. This document supersedes and replaces all information supplied prior to the publication hereof.