



# NON ISOLATED BUCK CONSTANT CURRENT LED DRIVER IC

### DESCRIPTION

**UL98B** is a high precision LED BUCK constant current driver chip. The chip operates in the inductor current critical continuous mode, which is suitable for the non isolated buck LED constant current power supply with 85Vac~265Vac full range input voltage.

**UL98B** chip integrated 500V power switch by patent demagnetization detection technology and high voltage power supply technology, without detection and power supply for auxiliary winding, the peripheral devices are more simple, saving the cost and volume of the system.

**UL98B** chip with high precision current sampling circuit, while the use of patented constant current control technology to achieve high accuracy of the LED constant current output and excellent line voltage regulator. The chip operates in the critical mode of inductor current and the output current is not changed with the increase of the inductance and the working voltage of LED.

**UL98B** has a variety of protection features, including LED short circuit protection, under voltage protection, over temperature adjustment function and so on.

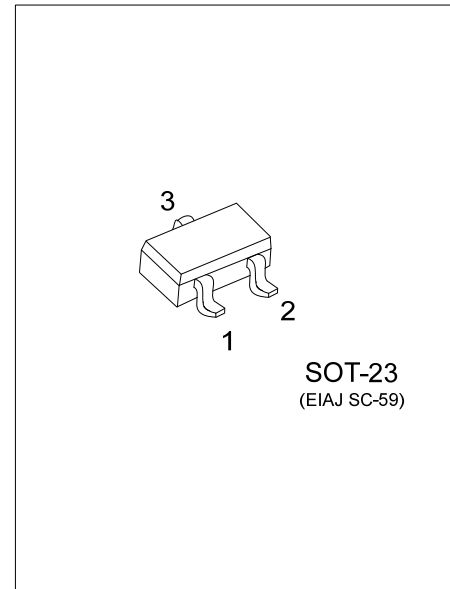

### FEATURES

- \* The integrated 500V power mos.
- \* The integrated high voltage power supply function.
- \* The inductor current critical continuous mode.
- \* Without auxiliary winding detection and power supply.
- \* The wide voltage input voltage.
- \* ±5% LED output current accuracy.
- \* The LED short circuit and open circuit protection.
- \* The chip power supply under voltage protection.
- \* The regulating function of overheating

### ORDERING INFORMATION

Ordering Number		Package	Packing
Lead Free	Halogen Free		
UL98BL-AE3-R	UL98BG-AE3-R	SOT-23	Tape Reel

<p>UL98AG-AE3-R</p> <ul style="list-style-type: none"> <li>(1) Packing Type</li> <li>(2) Package Type</li> <li>(3) Green Package</li> </ul>	<ul style="list-style-type: none"> <li>(1) R: Tape Reel</li> <li>(2) AE3: SOT-23</li> <li>(3) G: Halogen Free and Lead Free, L: Lead Free</li> </ul>
---	--

■ MARKING

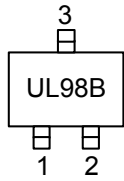

■ PIN CONFIGURATION

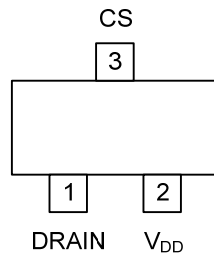

■ PIN DESCRIPTION

PIN NO.	PIN NAME	DESCRIPTION
1	DRAIN	The Internal High-Voltage Drain
2	V <sub>DD</sub>	Power Supply
3	CS	Float Ground and Current Sampling Pin

■ BLOCK DIAGRAM

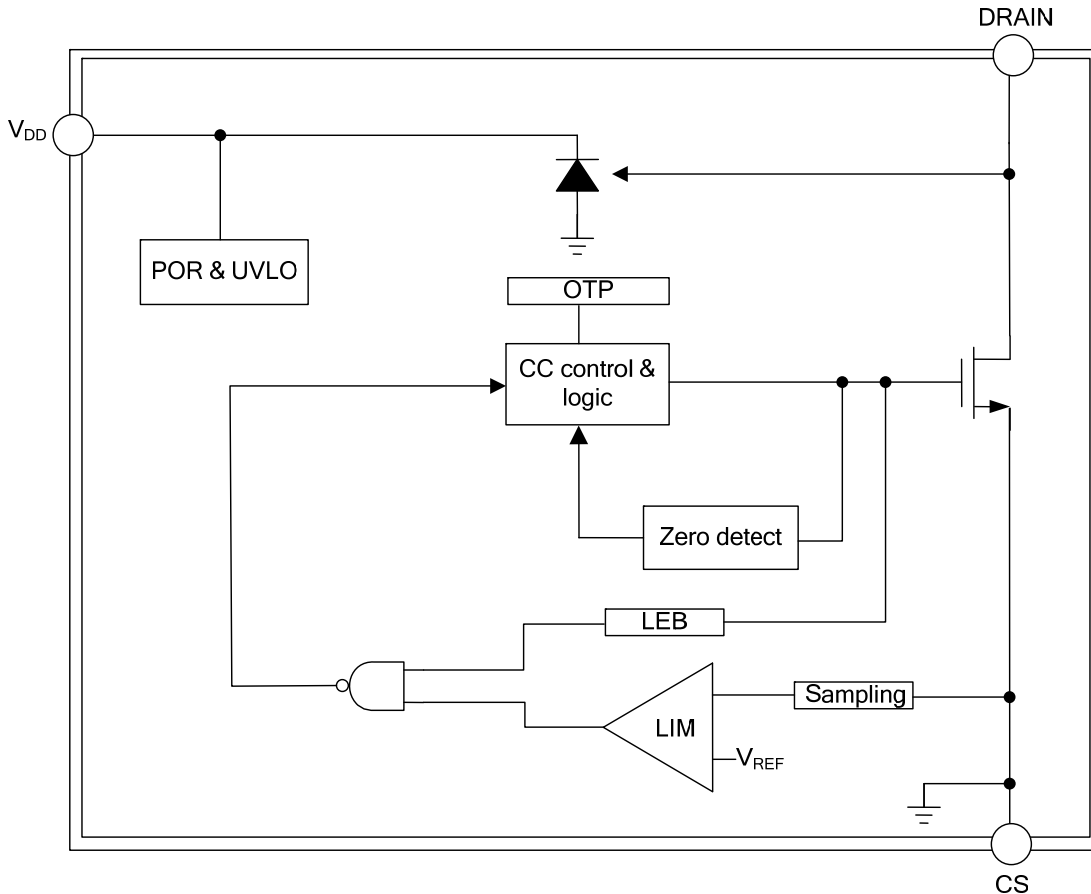

■ ABSOLUTE MAXIMUM RATING ( $T_A=25^{\circ}\text{C}$ , Unless otherwise specified)

PARAMETER	SYMBOL	RATINGS	UNIT
Input Voltage	$V_{IN}$	-0.3 ~ 550	V
Supply Voltage	$V_{DD}$	-0.3 ~ 8.5	V
Power Dissipation	$P_D$	300	mW
Junction Temperature	$T_J$	-45 ~ +125	$^{\circ}\text{C}$
Storage Temperature	$T_{STG}$	-55 ~ +150	$^{\circ}\text{C}$

Note: Absolute maximum ratings are those values beyond which the device could be permanently damaged.  
Absolute maximum ratings are stress ratings only and functional device operation is not implied.

■ RECOMMENDED OPERATION CONDITIONS

PARAMETER	SYMBOL	RATINGS	UNIT
Input Voltage	$V_{IN}$	140 ~ 375	V
Supply Voltage	$V_{DD}$	6 ~ 7	V
Reference Load Current	$I_{LOAD}$	0 ~ 200	mA
Ambient Temperature	$T_A$	0 ~ +70	$^{\circ}\text{C}$

■ THERMAL DATA

PARAMETER	SYMBOL	RATING	UNIT
Junction to Ambient	$\theta_{JA}$	416	$^{\circ}\text{C}/\text{W}$

■ ELECTRICAL CHARACTERISTICS (T<sub>A</sub>=25°C, Unless otherwise specified)

PARAMETER	SYMBOL	TEST CONDITIONS	MIN	TYP	MAX	UNIT
<b>POWER SUPPLY SECTION</b>						
Input Voltage	V <sub>IN</sub>		85	220	265	V
Output LED Current	I <sub>LED</sub>		0	100	150	mA
Chip Operating Voltage	V <sub>DD</sub>	DRAIN=100V	6	6.6	7.2	V
Chip Starting Voltage	V <sub>DD_ON</sub>	V <sub>DD</sub> rise	5	5.3	5.6	V
Chip Starting Current	I <sub>ST</sub>	V <sub>DD</sub> =5.3V	0.5	1	2	mA
Chip Operating Current	I <sub>CC</sub>		120	180	300	uA
Power Efficiency	η	I <sub>LED</sub> =100mA	0.88			
Power Factor	P <sub>F</sub>	I <sub>LED</sub> =100mA	0.4	0.5	0.7	
<b>CC SECTION</b>						
The Precision of Constant Current	CC	I <sub>LED</sub> =0mA~200mA		±5		%
Standby Power Consumption					0.3	W
<b>PROTECTION SECTION</b>						
Short Circuit Protection Frequency	F <sub>ST</sub>	V <sub>IN</sub> =220AC, RCS=3Ω	2	3	4	KHz
Current Detection Threshold	V <sub>CS_TH</sub>		580	600	620	mV
Edge Blanking Time	T <sub>LEB</sub>			500		ns
Turn Off Delay Time	T <sub>OFF_DELAY</sub>			200		ns
<b>TIME CONTROL SECTION</b>						
Minimum Turn Off Time	T <sub>OFF_MIN</sub>			2.5		us
Maximum Turn off Time	T <sub>OFF_MAX</sub>			300		us
Maximum Turn-on Time	T <sub>ON_MAX</sub>			40		us
<b>POWER MOS SECTION</b>						
LDMOS Withstand Voltage	B <sub>V</sub>		500	550	600	V
Conduction Resistance	R <sub>ON</sub>	I <sub>DS</sub> =0.1A		18		Ω
<b>TEMPER SECTION</b>						
Over Temper Adjust				140		°C
Over Temper Protect				160		°C
Over Temper Hysteresis				20		°C

Notes: 1. The parameters are not 100% tested in production.

2. The minimum, maximum range of standard specification by the test to ensure, typical values by design, test or analysis to ensure.

## ■ APPLICATION INFORMATION

### Application information

**UL98B** is a constant current driver IC for LED lighting, which is applied to the non isolated LED driver power supply.

The 500V power switch is integrated in the chip, which is based on the constant current architecture and control method, and it can achieve excellent constant current characteristics with minimal external components.

And without auxiliary winding power supply and testing, the system cost is very low.

### Start

After the system is powered up, the input voltage is charged on the  $V_{CC}$  pin through the jfet, and when the  $V_{CC}$  voltage reaches the threshold value, the chip's internal reference circuit begins to work. When the chip is working normally, the required operating current is still through the supply of internal consumption.

### Constant current control

The chip is detected the peak current, and the RCS resistance is connected to the input terminal of the peak comparator, which is compared with the threshold voltage 0.6V. When the RCS voltage reaches the threshold, the LED current is adjusted, and realized the constant current control.

The formula for calculating the inductor peak current is  $I_{PK}=600/RCS$  (mA).

Among them, RCS is a current sampling resistor.

The output of the comparator CS also includes a 500ns leading edge blanking time.

The formula for calculating the LED average current is  $I_{LED}=I_{PK}/2$ .

Among them,  $I_{PK}$  is the inductor peak current.

### Protection function

**UL98B** built in a variety of protection functions, including LED short-circuit protection, LED open circuit protection, sampling circuit short-circuit protection, temperature regulation and protection, etc.

When LED short circuit, the system works in the 3 KHz low frequency, so the power consumption is very low.

### Over temperature adjustment function

**UL98B** has the function of over temperature adjustment, the output current is gradually reduced when the driving power is over, so that the output power and temperature rise is controlled, the power supply is maintained at the set value,

In order to improve the reliability of the system, the chip is internally set to adjust the temperature of the 140°C.

### PCB design

In the design of PCB, you need to follow the following guidelines:

$V_{CC}$  bypass capacitor is required to close the  $V_{CC}$  pin of the chip.

RCS resistor requires close to the CS pin of the chip

Between RCS and  $V_{CC}$  bypass capacitor resistor connected to the copper foil as short as possible

CS pin increases in the area of copper clad to improve chip cooling.

■ TYPICAL APPLICATION CIRCUIT

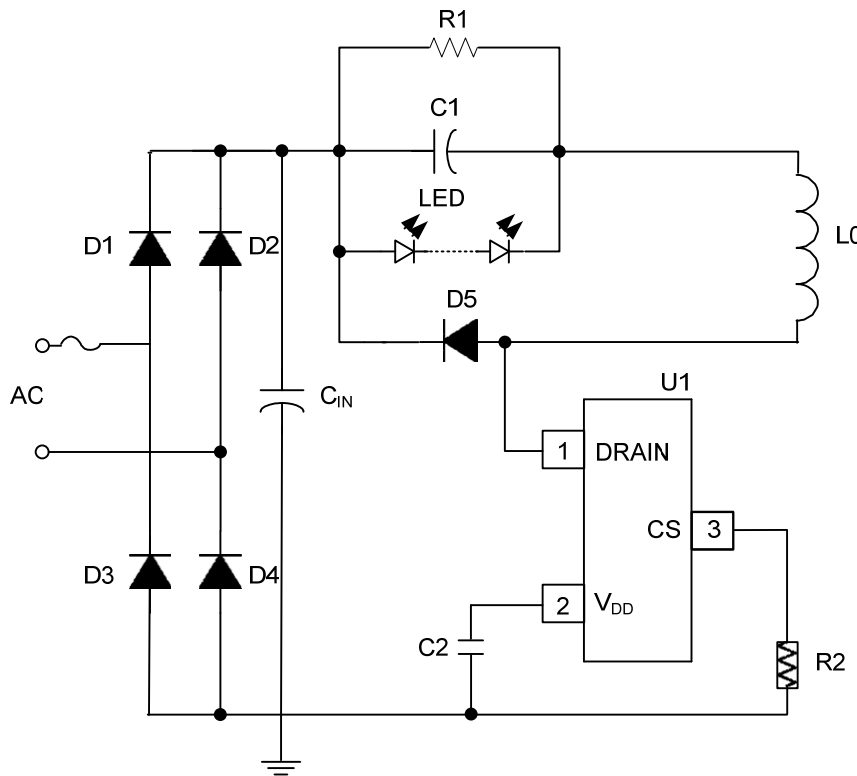

**BOM**

Reference	Component
R1	750K, 1206
R2	3Ω, 1206
C1	2.2µF, 1KV
C2	1µF / 50V, 0805
C <sub>IN</sub>	6.8µF, 400V
D1 ~ D4	1N4007
D5	ES1J, SMA
L0	4.7mH
U1	<b>UL98B</b>

UTC assumes no responsibility for equipment failures that result from using products at values that exceed, even momentarily, rated values (such as maximum ratings, operating condition ranges, or other parameters) listed in products specifications of any and all UTC products described or contained herein. UTC products are not designed for use in life support appliances, devices or systems where malfunction of these products can be reasonably expected to result in personal injury. Reproduction in whole or in part is prohibited without the prior written consent of the copyright owner. UTC reserves the right to make changes to information published in this document, including without limitation specifications and product descriptions, at any time and without notice. This document supersedes and replaces all information supplied prior to the publication hereof.