



UTRS3238

Preliminary

CMOS IC

+3.3V TO +5.0V POWER SUPPLY, 250KBPS, RS-232 LINE DRIVERS/RECEIVERS

■ DESCRIPTION

The UTC **UTRS3238** consists of 5 drivers and 3 receivers. It meets EIA/TIA-232 and V.28/V.24 specifications, it intended for notebook computer applications. A high-efficiency, dual charge-pumps power supply and a low-dropout transmitter combine to deliver true RS-232 performance from a single +3.3V ~ +5.0V power supply. A guaranteed data rate of 250kbps provides compatibility with popular software for communicating with PCs.

The UTC **UTRS3238** achieves 1 μ A supply current in shutdown condition. When the **UTRS3238** doesn't detect a valid signal level on its receiver inputs, the on-board power supply and drivers will shutdown, and when a valid level is applied to any RS-232 receiver input, then the system turns on again. Therefore, the system saves power without changes to the existing BIOS or operating system.

The UTC **UTRS3238** requires only 0.1 μ F capacitors in 3.3V operation, and can operate from input voltages ranging from +3.3V ~ +5.0V. It is ideal for 3.3V-only systems, 5.0V-only systems, or mixed 3.3V and 5.0V systems that require true RS-232 performance.

The UTC **UTRS3238** includes one complementary always-active receiver that can monitor an external device (such as a modem) in shutdown, without forward biasing the protection diodes in a UART that may have V_{CC} completely removed.

■ FEATURES

- * Operates With 3.3V~5.0V Power Supply
- * Five Drivers and Three Receivers
- * Operates Up To 250 kbps
- * Designed to Transmit at a Data Rate of 250 kbps
- * Low Standby Current (1 μ A Typical)
- * External Capacitors (4*0.1 μ F)
- * Accepts 5.0V Logic Input With 3.3V Supply
- * Always-Active Non-inverting Receiver Output (R_{1OUTB})
- * Serial-Mouse Drivability
- * Exceeds \pm 8KV ESD Protection(HBM) for RS-232 I/O Pins

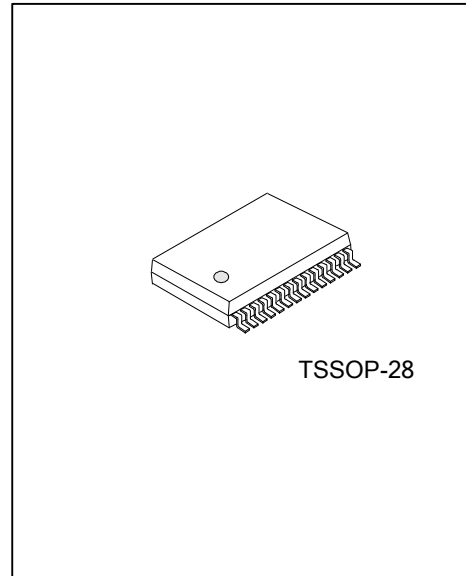

■ ORDERING INFORMATION

Ordering Number		Package	Packing
Lead Free	Halogen Free		
UTRS3238L-P28-R	UTRS3238G-P28-R	TSSOP-28	Tape Reel

<p>UTRS3238G-P28-R</p> <p>(1) Packing Type (2) Package Type (3) Green Package</p>	<p>(1) R: Tape Reel (2) P28: TSSOP-28 (3) G: Halogen Free and Lead Free, L: Lead Free</p>
---	---

■ MARKING

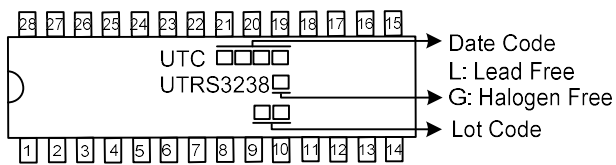

■ PIN CONFIGURATION

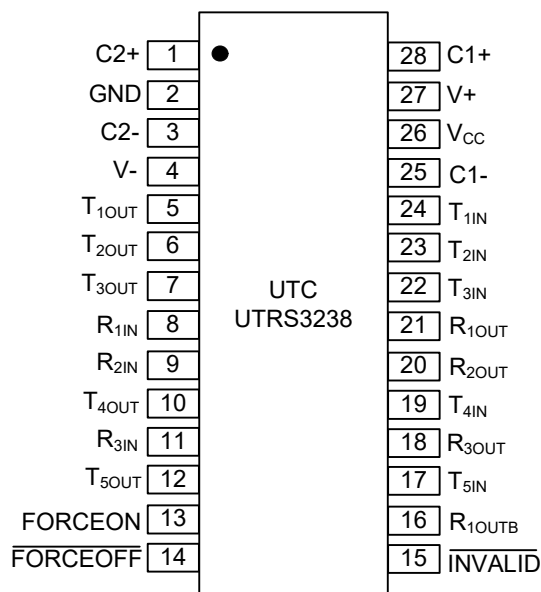

■ PIN DESCRIPTION

PIN NO.	PIN NAME	DESCRIPTION
1	C2+	Positive terminal of inverting charge-pump capacitor
2	GND	Ground.
3	C2-	Negative terminal of inverting charge-pump capacitor.
4	V-	-5.5V generated by the charge pump.
5~7,10,12	T _{XOUT}	RS-232 Transmitter Outputs.
8,9,11	R _{XIN}	RS-232 Receiver Inputs.
13	FORCEON	Drive high to override automatic circuitry keeping transmitters on ($\overline{\text{FORCEOFF}}$ must be high) (Table 2).
14	$\overline{\text{FORCEOFF}}$	Drive low to shut down transmitters and on-board power supply. This over-rides all automatic circuitry and FORCEON (Table 2).
15	$\overline{\text{INVALID}}$	Output of the valid signal detector. Indicates if a valid RS-232 level is present on receiver inputs logic "1".
16	R _{1OUTB}	Noninverting Receiver Output-active in shutdown.
17,19,22~24	T _{XIN}	TTL/CMOS Transmitter Inputs.
18,20,21	R _{XOUT}	TTL/CMOS Receiver Outputs.
25	C1-	Negative terminal of the voltage doubler charge-pump capacitor.
26	V _{CC}	+3.3V ~ +5.0V Supply Voltage.
27	V+	+5.5V generated by the charge pump.
28	C1+	Positive terminal of the voltage doubler charge-pump capacitor.

■ BLOCK DIAGRAM

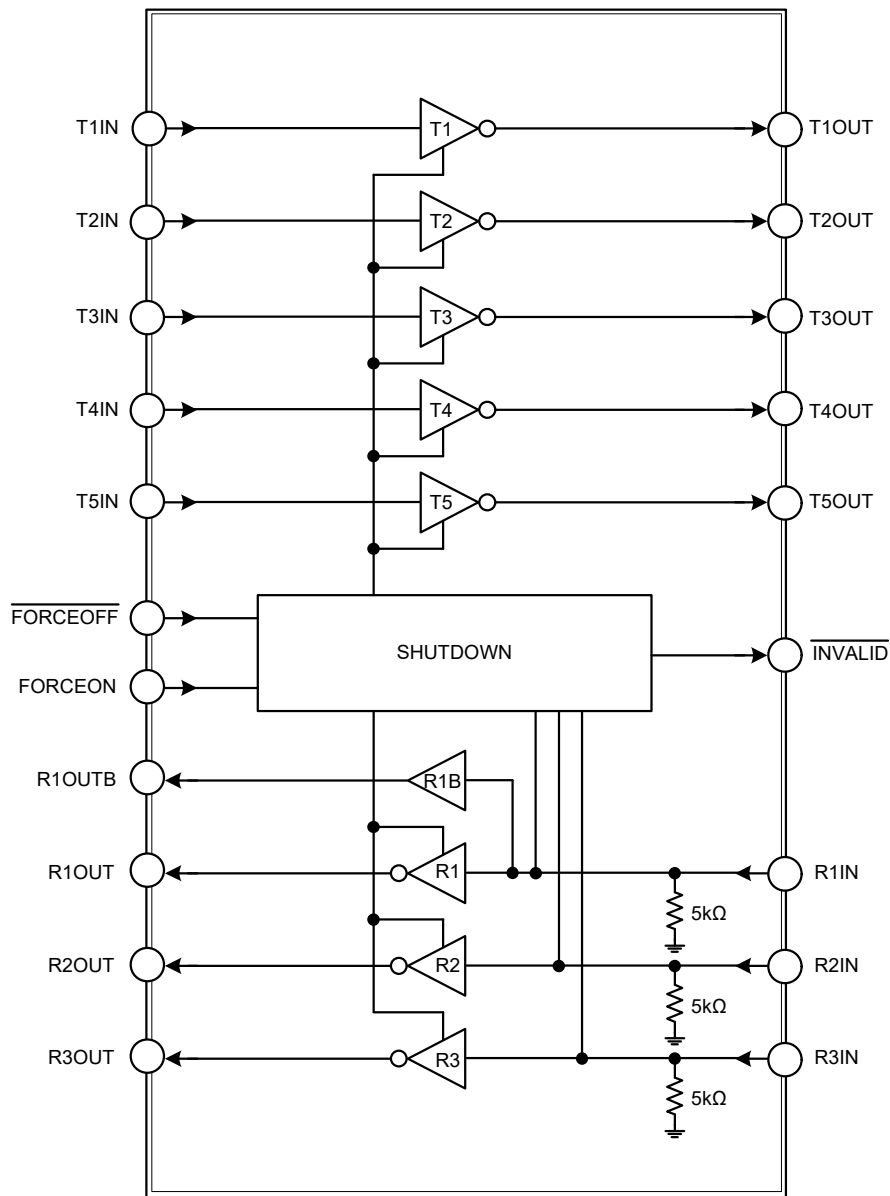

■ ABSOLUTE MAXIMUM RATING

PARAMETER		SYMBOL	RATINGS	UNIT
V _{CC}		V _{CC}	6.0	V
V+ (Note 2)		V+	7.0	V
V- (Note 2)		V-	-7.0	V
V+ + V- (Note 2)		V _{PUMP}	+13.0	V
Input Voltages	T1IN~T5IN, FORCEOFF, FORCEON	V _{IN}	-0.3 ~ +6.0	V
	R1IN~R3IN		±25	V
Output Voltages	T1OUT~T5OUT	V _{OUT}	±13.2	V
	R1OUT~R3OUT, R1OUTB, INVALID		-0.3 ~ (V _{CC} +0.3)	V
Short-Circuit Duration	T1OUT ~ T5OUT	SC	Continuous	
Power Dissipation(T _A =25°C)		P _D	870	mW
Operating Temperature		T _{OPR}	-40 ~ +85	°C
Storage Temperature		T _{STG}	-65 ~ +150	°C

Notes: 1. Absolute maximum ratings are those values beyond which the device could be permanently damaged. Absolute maximum ratings are stress ratings only and functional device operation is not implied.
 2. V+ and V- can have maximum magnitudes of 7.0V, but their absolute difference cannot exceed 13.0V.

■ ELECTRICAL CHARACTERISTICS

(V_{CC}=+3.3V~+5.0V, C1~C4=0.1µF (Note 2), T_A = T_{MIN} to T_{MAX}, unless otherwise specified)

PARAMETER		SYMBOL	TEST CONDITIONS	MIN	TYP	MAX	UNIT
DC CHARACTERISTICS							
Supply Current, Shutdown	I _{SHDN}	V _{CC} =3.3V or 5.0V, T _A = 25°C	All R _{IN} open, FORCEOFF =V _{CC} , FORCEON=GND		1.0	10	µA
			FORCEOFF =GND, All R _{IN} =GND		1.0	10	µA
Supply Current, Shutdown Disabled	I _{CC}		FORCEON= FORCEOFF =V _{CC} , no load		0.5	2.0	mA
LOGIC INPUTS							
Input Logic Threshold	Low	V _{LGL}	T _{IN} , FORCEON, FORCEOFF			0.8	V
	High	V _{LGH}	T _{IN} , FORCEON, FORCEOFF	V _{CC} = 3.3V V _{CC} = 5.0V	2.0 2.4		V
Input Leakage Current	I _{IN(LK)}		T _{IN} , FORCEON, FORCEOFF		±0.01	±1.0	µA
RECEIVER OUTPUTS							
Output Leakage Current	I _{ROUT(LK)}		Receivers disabled		±0.05	±10	µA
Output Voltage	Low	V _{ROU_TL}	I _{OUT} = 1.6mA			0.4	V
	High	V _{ROU_TH}	I _{OUT} = -1.0mA	V _{CC} - 0.6	V _{CC} - 0.1		V
AUTOSHUTDOWN (FORCEON=GND, FORCEOFF =V_{CC})							
Receiver Input Thresholds to Transmitters	Enabled	V _{R(EN)}	Fig.1	Positive threshold		2.7	V
	Disabled	V _{R(DIS)}	1µA supply current, Fig.1	Negative threshold	-2.7		V
INVALID Output Voltage	Low	V _{INVL}	I _{OUT} =1.6mA			0.4	V
	High	V _{INVH}	I _{OUT} =-1.0mA	V _{CC} - 0.6			V
Receiver or Transmitter Edge to Transmitters Enabled	t _{WU}		Fig.2		25		µs
Receiver or Transmitter Edge to Transmitters Shutdown	t _{AUTOSH_{DN}}		Fig.2	15	30	60	s

■ ELECTRICAL CHARACTERISTICS(Cont.)

($V_{CC}=+3.3V\sim+5.0V$, $C1\sim C4=0.1\mu F$ (Note 2), $T_A = T_{MIN}$ to T_{MAX} , Unless Otherwise Specified)

PARAMETER		SYMBOL	TEST CONDITIONS	MIN	TYP	MAX	UNIT	
Receiver Positive or Negative Threshold to INVALID	High	t_{INVH}	Fig.2		0.1		μs	
	Low	t_{INVL}			30		μs	
RECEIVER INPUTS								
Input Voltage Range		V_{RR}		-25		25	V	
Input Threshold Low		V_{RINL}	$T_A=25^\circ C$	$V_{CC}=3.3V$	0.6	1.2	V	
				$V_{CC}=5.0V$	0.8	1.5		
Input Threshold High		V_{RINH}	$T_A=25^\circ C$	$V_{CC}=3.3V$		1.5	2.4	V
				$V_{CC}=5.0V$		1.8	2.4	
Input Hysteresis		V_{RINHYS}			0.3		V	
Input Resistance		V_{RINRES}	$T_A=25^\circ C$	3	5	7	k Ω	
TRANSMITTER OUTPUTS								
Output Voltage Swing		V_{TOUTSW}	All transmitter outputs loaded with 3k Ω to ground		± 5.0		V	
Output Resistance		$V_{TOUTRES}$	$V_{CC}=V+=V-=0V$, Transmitter output= $\pm 2V$	300	10M		Ω	
Output Short-Circuit Current		I_{TSC}			± 35	± 60	mA	
Output Leakage Current		$I_{TOUT(LK)}$	$V_{CC}=3.3V\sim 5.0V$, $V_{OUT}=\pm 12V$, Transmitters disabled			± 25	μA	
TIMING CHARACTERISTICS								
Maximum Data Rate		DR	$R_L=3k\Omega$, $C_L=1000pF$, one transmitter switching	250			kbps	
Receiver Propagation Delay		t_{PHL}	Receiver input to receiver output, $C_L=150pF$		0.15		μs	
		t_{PLH}			0.15			
Receiver Output Time	Enable	$t_{R(EN)}$	Normal operation		200		ns	
	Disable	$t_{R(DIS)}$			200			
Transmitter Skew		t_{TS}	$ t_{PHL} - t_{PLH} $		100		ns	
Receiver Skew		t_{RS}	$ t_{PHL} - t_{PLH} $		50		ns	
Transition-Region Slew Rate		SR	$V_{CC}=3.3V$, $T_A=25^\circ C$, $R_L=3k\Omega\sim 7k\Omega$, measured from +3V $\sim -3V$ or -3V $\sim +3V$	$C_L=150pF\sim 1000pF$	6	30	V/ μs	
				$C_L=150pF\sim 2500pF$	4	30	V/ μs	

Notes: 1. Typical values are at $V_{CC}=3.3V$ or $V_{CC}=5.0V$, and $T_A=25^\circ C$.

2. Testing supply conditions are $C1\sim C4=0.1\mu F$ at $V_{CC}=3.3V \pm 0.15V$; $C1\sim C4=0.22\mu F$ at $V_{CC}=3.3V \pm 0.3V$; $C1=0.047\mu F$ and $C2\sim C4=0.33\mu F$ at $V_{CC}=5.0V \pm 0.5V$.

■ DETAILED DESCRIPTION

Charge-Pump Voltage Converter

The UTC **UTRS3238** consists of a regulated dual charge pumps that provide output voltages of +5.5V and -5.5V, regardless of the input voltage (V_{CC}) changing from +3.3V to +5.0V.

The charge pumps operate in a discontinuous mode: if the output voltages are less than 5.5V, the charge pumps are enabled; if the output voltages exceed 5.5V, the charge pumps are disabled.

Each charge pump requires a flying capacitor (C1, C2) and a reservoir capacitor (C3, C4) to generate the V+ and V- supplies, refer to application circuit.

RS-232 Transmitter

UTC **UTRS3238**'s transmitters are inverting level translators that convert CMOS-logic levels to 5.0V EIA/TIA-232 levels. They guarantee a 250kbps data rate with worst-case loads of $3k\Omega$ in parallel with 1000pF, providing compatibility with PC-to-PC communication software. Typically, the UTC **UTRS3238** can operate at data rates of 235kbps.

Transmitters can be paralleled to drive multiple receivers or mouse. When $\overline{FORCEOFF}$ is driven to ground, or shutdown circuitry senses invalid voltage levels at all receiver inputs, the transmitters are disabled and the outputs are forced into a high-impedance state.

RS-232 Receiver

The UTC **UTRS3238**'s receivers convert RS-232 signals to CMOS-logic output levels. All receivers have one inverting three-state output. If the receivers is in shutdown, the outputs of receivers are high impedance.

The UTC **UTRS3238** has an always-active complementary output (R_{1OUTB}). R_{1OUTB} is an extra output that monitors receiver activity while the other receivers are high impedance. This allows Ring Indicator to be monitored without forward biasing other devices connected to the receiver outputs. This is ideal for systems where V_{CC} is set to 0V in shutdown to accommodate peripherals.

Table 1. $\overline{INVALID}$ Control Truth Table

RS-232 SIGNAL PRESENT AT RECEIVER INPUT	$\overline{INVALID}$ OUTPUT
YES	High
NO	Low

Shutdown Function

A $1\mu A$ supply current is achieved with shutdown feature, which operates when FORCEON is low and $\overline{FORCEOFF}$ is high. When the UTC **UTRS3238** do not sense a valid signal transition on any receiver and transmitter input for 30sec, the on-board charge pumps are shutdown, reducing supply current to $1\mu A$. This occurs if the RS-232 cable is disconnected or the connected peripheral transmitters are turned off. The system turns on again when a valid transition is applied to any RS-232 receiver or transmitter input (Table 2). As a result, the system saves power without changes to the existing BIOS or operating system. $\overline{INVALID}$ indicates the receiver inputs' condition, when using shutdown function, the $\overline{INVALID}$ output is high when the device is on and low when the device is shut down.

Table 2. Shutdown Logic Control Truth Table

FORCEON	$\overline{FORCEOFF}$	Auto shutdown	Operation Status	T_OUT	R_OUT	R1OUTB
X	0	X	Shutdown(Forced off)	High-Z	High-Z	Active
1	1	X	Normal Operation(Forced on)	Active	Active	Active
0	1	<30sec*	Normal Operation(Auto shutdown)	Active	Active	Active
0	1	>30sec*	Shutdown(Auto shutdown)	High-Z	Active	Active

X=Do not care

* Time since last receiver or transmitter input transition.

■ DETAILED DESCRIPTION(Cont.)

Figure 1 depicts valid and invalid RS-232 receiver voltage levels. INVALID indicates the receiver input's condition, and is independent of FORCEON and FORCEOFF states.

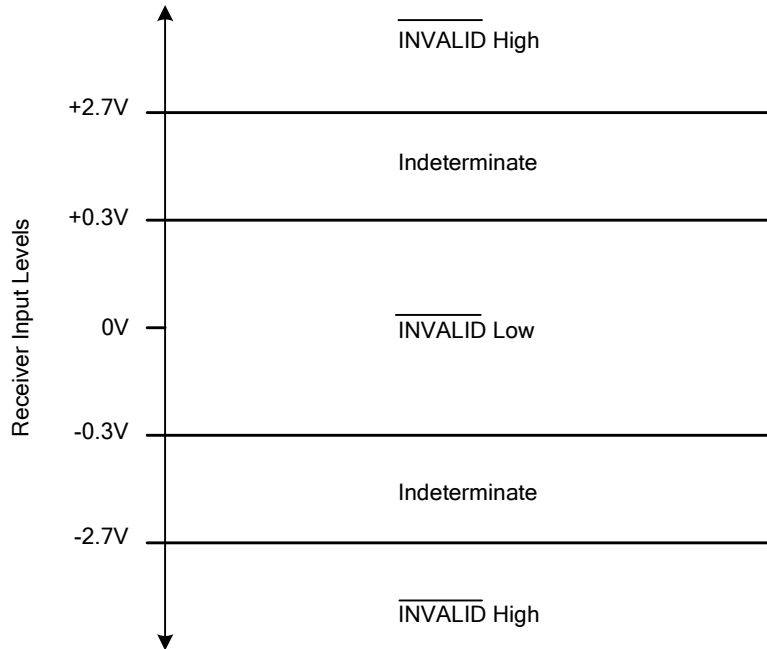

Fig.1 Shutdown Input Levels

When shutdown, the UTC UTRS3238's charge pumps are turned off, V+ decays to V_{CC}, V- decays to ground, the transmitter output is disabled (high impedance). The time required to exit shutdown is typically 25μs.

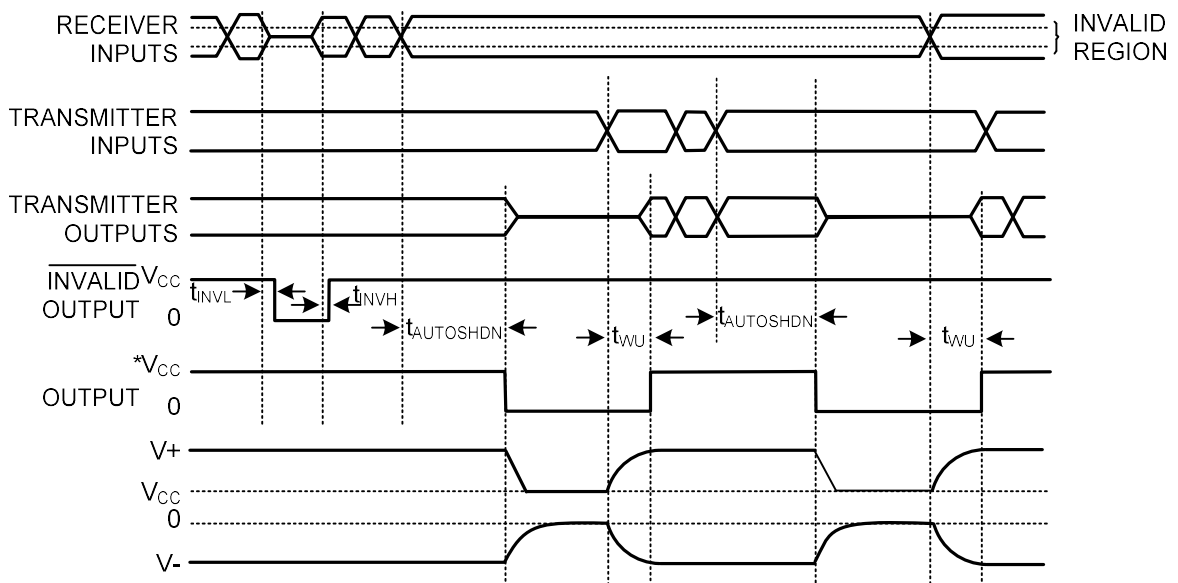

Fig.2 Shutdown Input Timing

■ TYPICAL APPLICATION CIRCUIT

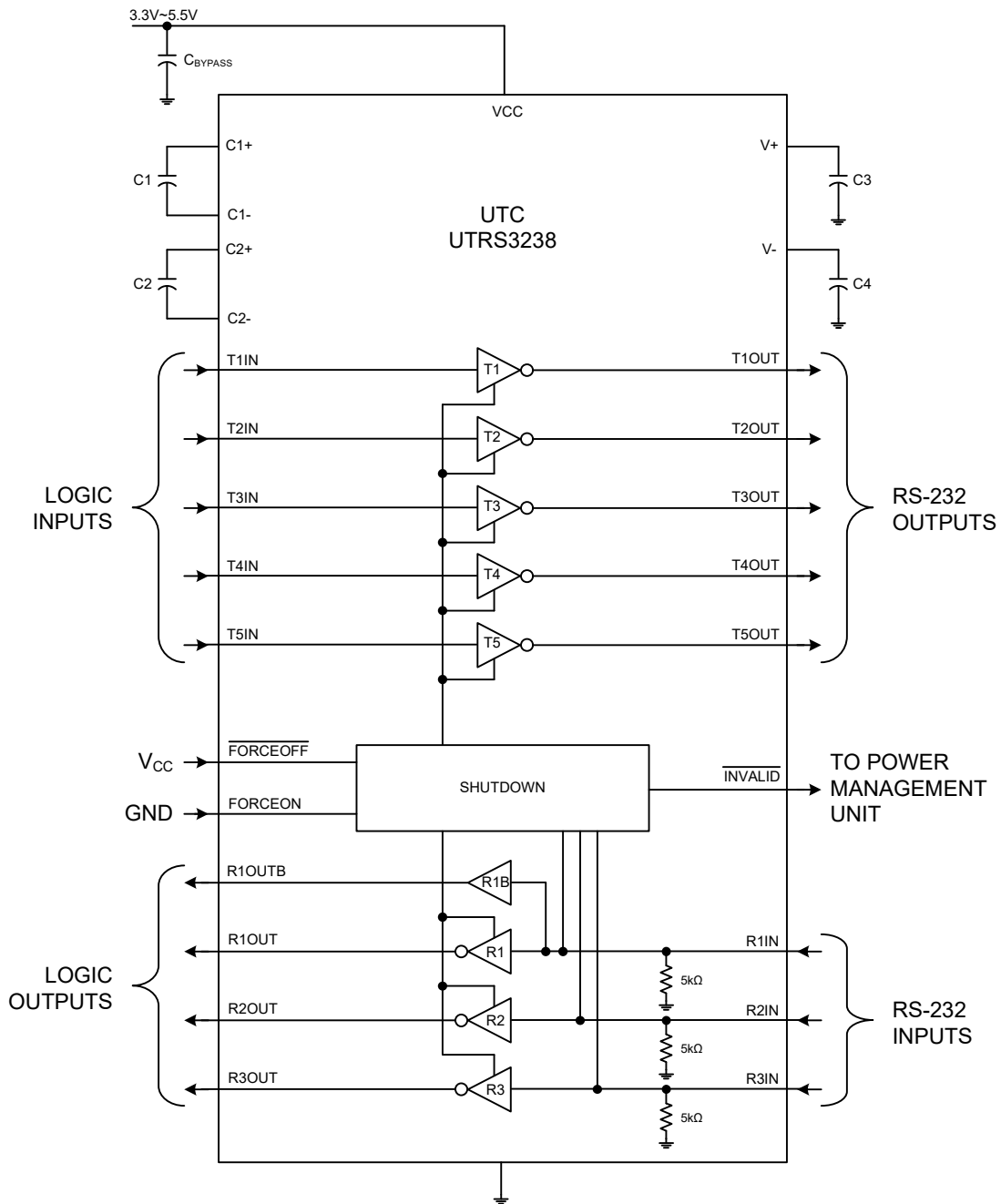

Fig.3 Application Circuit

Table 3. Required Capacitor Value

V _{CC} (V)	C1 (μF)	C2, C3, C4 (μF)	C _{BYPASS} (μF)
3.3~3.6	0.1	0.1	0.1
4.5~5.5	0.047	0.33	0.047
3.3~5.5	0.22	1.0	0.22

UTC assumes no responsibility for equipment failures that result from using products at values that exceed, even momentarily, rated values (such as maximum ratings, operating condition ranges, or other parameters) listed in products specifications of any and all UTC products described or contained herein. UTC products are not designed for use in life support appliances, devices or systems where malfunction of these products can be reasonably expected to result in personal injury. Reproduction in whole or in part is prohibited without the prior written consent of the copyright owner. UTC reserves the right to make changes to information published in this document, including without limitation specifications and product descriptions, at any time and without notice. This document supersedes and replaces all information supplied prior to the publication hereof.