

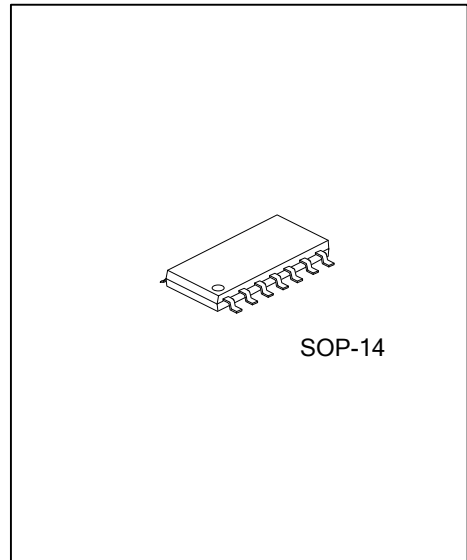

## ULN202L05

## LINEAR INTEGRATED CIRCUIT

### 4-CH DARLINGTON SINK DRIVER AND 3-TERMINAL 0.2A 5V VOLTAGE REGULATOR



#### DESCRIPTION

The UTC **ULN202L05** is comprised of 4-ch Darlington Sink Driver and 3-TERMINAL Voltage Regulator.

The Sink Driver is a high-voltage, high-current NPN darlington driver. Every channel includes clamp diode for switching inductive load. The applications of the UTC **ULN202L05** include relay, hammer, lamp and display (LED) drivers.

The 5V Voltage Regulator is a three-terminal regulator with 0.2A output current capability.

#### FEATURES

##### For Darlington Sink Drivers

- \* Output current (single output): 500mA max
- \* High sustaining voltage output: 50V min
- \* Output clamp diodes
- \* Inputs compatible with various types of logic

##### For 5V VOLTAGE REGULATOR

- \* Output Current up to 200mA
- \* Thermal Overload Shutdown Protection
- \* Short Circuit Current Limiting

#### ORDERING INFORMATION

Ordering Number		Package	Packing
Lead Free	Halogen Free		
ULN202L05L-S14-R	ULN202L05G-S14-R	SOP-14	Tape Reel
ULN202L05L-S14-T	ULN202L05G-S14-T	SOP-14	Tube

<p>ULN202L05G-S14-R</p> <p>(1)Packing Type</p> <p>(2)Package Type</p> <p>(3)Green Package</p>	<p>(1) R: Tape Reel</p> <p>(2) S14: SOP-14</p> <p>(3) G: Halogen Free and Lead Free, L: Lead Free</p>
---	---

#### MARKING

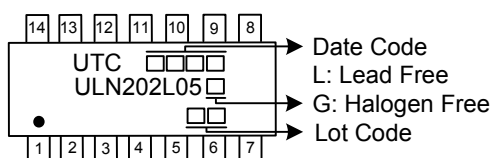

### ■ PIN CONFIGURATION

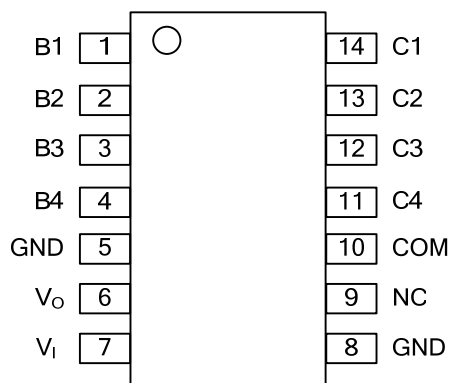

### ■ PIN DESCRIPTION

PIN NO.	PIN NAME	DESCRIPTION
1	B1	Input of the 1st-ch Darlington Sink Driver
2	B2	Input of the 2nd-ch Darlington Sink Driver
3	B3	Input of the 3rd-ch Darlington Sink Driver
4	B4	Input of the 4th-ch Darlington Sink Driver
5	GND	Ground of Darlington Sink Drivers
6	$V_o$	Output of 5V Voltage Regulator
7	$V_i$	Input of 5V Voltage Regulator
8	GND	Ground of 5V Voltage Regulator
9	NC	No connection
10	COM	COMMON of Darlington Sink Drivers
11	C4	Output of the 4th-ch Darlington Sink Driver
12	C3	Output of the 3rd-ch Darlington Sink Driver
13	C2	Output of the 2nd-ch Darlington Sink Driver
14	C1	Output of the 1st-ch Darlington Sink Driver

### ■ BLOCK DIAGRAM

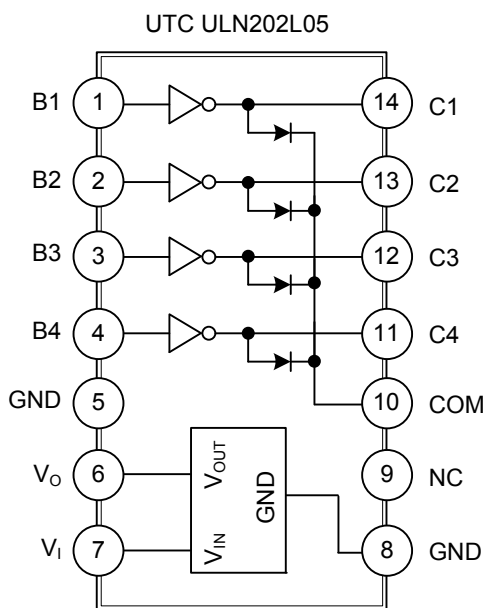

## ■ ABSOLUTE MAXIMUM RATING

PARAMETER	SYMBOL	RATING	UNIT
Power Dissipation ( $T_A=25^\circ\text{C}$ )	$P_D$	0.9	W
Junction Temperature	$T_J$	+125	$^\circ\text{C}$
Operating Temperature	$T_{OPR}$	-40 ~ +85	$^\circ\text{C}$
Storage Temperature	$T_{STG}$	-55 ~ +150	$^\circ\text{C}$
<b>Darlington Sink Drivers</b>			
Output Sustaining Voltage	$V_{OUT}$	-0.5 ~ 50	V
Input Voltage	$V_{IN}$	-0.5 ~ 30	V
Clamp Diode Reverse Voltage	$V_R$	50	V
Output Current	$I_{OUT}$	500	mA/ch
Clamp Diode Forward Current	$I_F$	500	mA
<b>5V VOLTAGE REGULATOR</b>			
Input Voltage	$V_{IN}$	30	V
Output Current	$I_{OUT}$	200	mA

## ■ ELECTRICAL CHARACTERISTICS

### Darlington Sink Drivers ( $T_A = 25^\circ\text{C}$ unless otherwise specified)

PARAMETER	SYMBOL	TEST CONDITIONS	MIN	TYP	MAX	UNIT	
Output Leakage Current	$I_{LEAK}$	$V_{CE}=50\text{V}, T_A=25^\circ\text{C}$			50	$\mu\text{A}$	
		$V_{CE}=50\text{V}, T_A=85^\circ\text{C}$			100		
Collector-Emitter Saturation Voltage	$V_{CE(SAT)}$	$I_{OUT}=350\text{mA}, I_{IN}=500\mu\text{A}$		1.3	1.6	V	
		$I_{OUT}=200\text{mA}, I_{IN}=350\mu\text{A}$		1.1	1.3		
		$I_{OUT}=100\text{mA}, I_{IN}=250\mu\text{A}$		0.9	1.1		
DC Current Transfer Ratio	$h_{FE}$	$V_{CE}=2\text{V}, I_{OUT}=350\text{mA}$	1000				
Input Current (Output On)	$I_{IN(ON)}$	$V_{IN}=2.4\text{V}, I_{OUT}=350\text{mA}$		0.4	0.7	mA	
Input Current (Output Off)	$I_{IN(OFF)}$	$I_{OUT}=500\mu\text{A}, T_A=85^\circ\text{C}$	50	65		$\mu\text{A}$	
Input Voltage (Output On)	$V_{IN(ON)}$	$V_{CE}=2\text{V}$			$I_{OUT}=350\text{mA}$	2.6	V
					$I_{OUT}=200\text{mA}$	2.0	
Clamp Diode Reverse Current	$I_R$	$V_R=50\text{V}, T_A=25^\circ\text{C}$			50	$\mu\text{A}$	
		$V_R=50\text{V}, T_A=85^\circ\text{C}$			100		
Clamp Diode Forward Voltage	$V_F$	$I_F=350\text{mA}$			2.0	V	
Input Capacitance	$C_{IN}$			15		pF	
Turn-On Delay	$t_{ON}$	$V_{OUT}=50\text{V}, R_L=125\Omega, C_L=15\text{pF}$		0.1		$\mu\text{s}$	
Turn-Off Delay	$t_{OFF}$	$V_{OUT}=50\text{V}, R_L=125\Omega, C_L=15\text{pF}$		0.2			

### ■ ELECTRICAL CHARACTERISTICS(Cont.)

#### 5V VOLTAGE REGULATOR

( $V_{IN}=10V$ ,  $I_{OUT}=40mA$ ,  $0^{\circ}C < T_J < 125^{\circ}C$ ,  $C_1=0.33\mu F$ ,  $C_o=0.1\mu F$ , unless otherwise specified) (Note 1)

PARAMETER	SYMBOL	TEST CONDITIONS	MIN	TYP	MAX	UNIT
Output Voltage	$V_{OUT}$	$T_J=25^{\circ}C$	4.80	5.0	5.20	V
		$7V \leq V_{IN} \leq 20V$ , $I_{OUT}=1mA-40mA$	4.75		5.25	
		$7V \leq V_{IN} \leq V_{MAX}$ , $I_{OUT}=1mA-200mA$ (Note 2)	4.75		5.25	V
Load Regulation	$\Delta V_{OUT}$	$T_J=25^{\circ}C$ , $I_{OUT}=1mA-100mA$		11	60	mV
		$T_J=25^{\circ}C$ , $I_{OUT}=1mA-40mA$		5.0	30	
Line regulation	$\Delta V_{OUT}$	$7V \leq V_{IN} \leq 20V$ , $T_J=25^{\circ}C$		8	150	mV
		$8V \leq V_{IN} \leq 20V$ , $T_J=25^{\circ}C$		6	100	
Quiescent Current	$I_Q$	$V_{IN}=10V$ , $I_{OUT}=0mA$ , $T_J=25^{\circ}C$		2.0	5.5	mA
Quiescent Current Change	$\Delta I_Q$	$8V \leq V_{IN} \leq 20V$			1.5	mA
		$1mA \leq V_{IN} \leq 40mA$			0.1	
Max output current	$I_{OUT(MAX)}$	$T_J=25^{\circ}C$	$V_{in}=7V$		400	mA
			$V_{in}=30V$		150	
Output Noise Voltage	$e_N$	$10Hz \leq f \leq 100kHz$		40		$\mu V$
Temperature coefficient of $V_{OUT}$	$\Delta V_O/\Delta T$	$I_{OUT}=5mA$		-0.65		$mV/^{\circ}C$
Ripple Rejection	RR	$8V \leq V_{IN} \leq 20V$ , $f=120Hz$ , $T_J=25^{\circ}C$	41	80		dB
Dropout Voltage	$V_D$	$T_J=25^{\circ}C$ , $I_{OUT}=100mA$		1.7		V

Notes: 1. The Maximum steady state usable output current are dependent on input voltage, heat sinking, lead length of the package and copper pattern of PCB. The data above represent pulse test conditions with junction temperatures specified at the initiation of test.

2. Power dissipation < 0.5W.

■ TYPICAL APPLICATION CIRCUIT

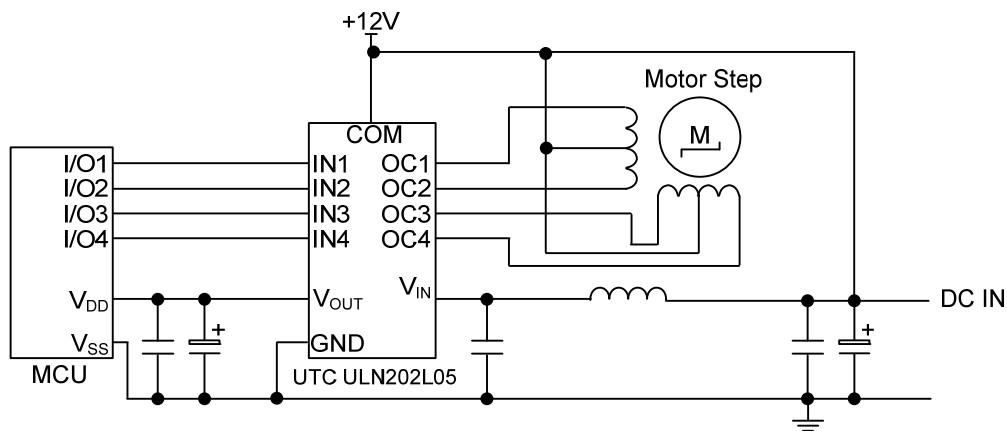

UTC assumes no responsibility for equipment failures that result from using products at values that exceed, even momentarily, rated values (such as maximum ratings, operating condition ranges, or other parameters) listed in products specifications of any and all UTC products described or contained herein. UTC products are not designed for use in life support appliances, devices or systems where malfunction of these products can be reasonably expected to result in personal injury. Reproduction in whole or in part is prohibited without the prior written consent of the copyright owner. UTC reserves the right to make changes to information published in this document, including without limitation specifications and product descriptions, at any time and without notice. This document supersedes and replaces all information supplied prior to the publication hereof.