



5NM70A

Preliminary

Power MOSFET

**5A, 700V N-CHANNEL
SUPER-JUNCTION MOSFET**

■ DESCRIPTION

The UTC **5NM70A** is a Super Junction MOSFET Structure and is designed to have better characteristics, such as fast switching time, low gate charge, low on-state resistance and high rugged avalanche characteristics. This power MOSFET is usually used in high speed switching applications at power supplies, PWM motor controls, high efficient AC to DC converters and bridge circuits.

■ FEATURES

- * $R_{DS(ON)} < 1.5\Omega @ V_{GS} = 10V, I_D = 2.5A$
- * Fast Switching Capability
- * Improved dv/dt Capability, High Ruggedness

■ SYMBOL

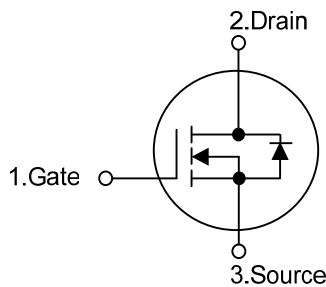

■ ORDERING INFORMATION

| Ordering Number | | Package | Pin Assignment | | | Packing |
|-----------------|----------------|-----------|----------------|---|---|-----------|
| Lead Free | Halogen Free | | 1 | 2 | 3 | |
| - | 5NM70AG-AA2-R | SOT-223-2 | G | D | S | Tape Reel |
| 5NM70AL-TMS2-T | 5NM70AG-TMS2-T | TO-251S2 | G | D | S | Tube |

Note: Pin Assignment: G: Gate D: Drain S: Source

| | |
|---|---|
| <p>5NM70G-AA2-R</p> <p>(1)Packing Type (2)Package Type (3)Green Package</p> | <p>(1) R: Tape Reel (2) AA2: SOT-223-2, TMS2: TO-251S2, (3) L: Lead Free, G: Halogen Free and Lead Free</p> |
|---|---|

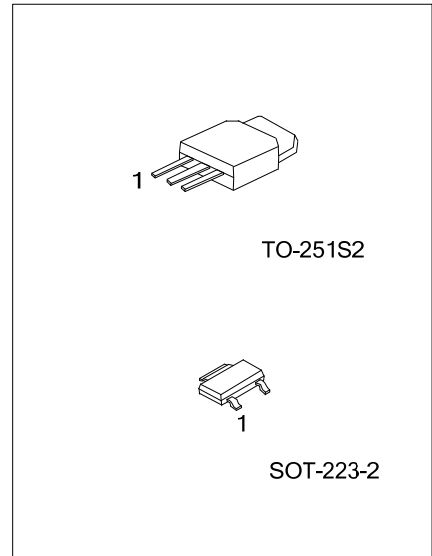

MARKING

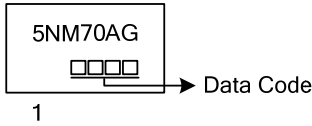
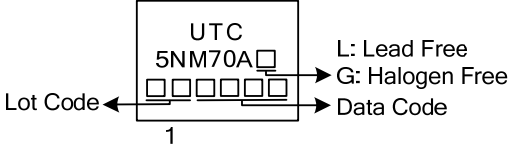
| SOT-223 | TO-251S2 |
|--|---|
|  <p>5NM70AG □□□ → Data Code 1</p> |  <p>UTC 5NM70A □ □□□□□ → Data Code Lot Code ← 1</p> <p>L: Lead Free G: Halogen Free</p> |

■ ABSOLUTE MAXIMUM RATINGS ($T_C = 25^\circ\text{C}$, unless otherwise specified)

| PARAMETER | | SYMBOL | RATINGS | UNIT | |
|------------------------------------|------------------------|-----------|-------------------------|------------------|----|
| Drain-Source Voltage | | V_{DSS} | 700 | V | |
| Gate-Source Voltage | | V_{GSS} | ± 30 | V | |
| Drain Current | Continuous | I_D | $T_C=25^\circ\text{C}$ | 5.0 | A |
| | | | $T_C=100^\circ\text{C}$ | 3.4 | A |
| | Pulsed (Note 2) | | I_{DM} | 20 | A |
| Avalanche Energy | Single Pulsed (Note 3) | | E_{AS} | 104 | mJ |
| Peak Diode Recovery dv/dt (Note 4) | | dv/dt | 3.0 | V/ns | |
| Power Dissipation | SOT-223-2 | P_D | 12 | W | |
| | TO-251S2 | | 54 | W | |
| Junction Temperature | | T_J | +150 | $^\circ\text{C}$ | |
| Storage Temperature | | T_{STG} | -55 ~ +150 | $^\circ\text{C}$ | |

Notes: 1. Absolute maximum ratings are those values beyond which the device could be permanently damaged.

Absolute maximum ratings are stress ratings only and functional device operation is not implied.

2. Repetitive Rating : Pulse width limited by maximum junction temperature.

3. $L=144\text{mH}$, $I_{AS}=1.2\text{A}$, $V_{DD}=50\text{V}$, $R_G=25\ \Omega$, Starting $T_J = 25^\circ\text{C}$

4. $I_{SD}\leq 5.0\text{A}$, $di/dt\leq 200\text{A}/\mu\text{s}$, $V_{DD}\leq BV_{DSS}$, Starting $T_J = 25^\circ\text{C}$

■ THERMAL DATA

| PARAMETER | | SYMBOL | RATINGS | UNIT |
|---------------------|-----------|---------------|---------|---------------------------|
| Junction to Ambient | SOT-223-2 | θ_{JA} | 150 | $^\circ\text{C}/\text{W}$ |
| | TO-251S2 | | 110 | $^\circ\text{C}/\text{W}$ |
| Junction to Case | SOT-223-2 | θ_{JC} | 10.4 | $^\circ\text{C}/\text{W}$ |
| | TO-251S2 | | 2.3 | $^\circ\text{C}/\text{W}$ |

■ ELECTRICAL CHARACTERISTICS (T_J = 25°C unless otherwise specified)

| PARAMETER | SYMBOL | TEST CONDITIONS | MIN | TYP | MAX | UNIT |
|--|---------------------|--|-----|------|------|------|
| OFF CHARACTERISTICS | | | | | | |
| Drain-Source Breakdown Voltage | BV _{DSS} | V _{GS} =0V, I _D =250μA | 700 | | | V |
| Drain-Source Leakage Current | I _{DSS} | V _{DS} =700V, V _{GS} =0V | | | 1 | μA |
| Gate-Source Leakage Current | Forward | V _{GS} =30V, V _{DS} =0V V _{GS} =-30V, V _{DS} =0V | | | 100 | nA |
| | Reverse | | | | -100 | |
| ON CHARACTERISTICS | | | | | | |
| Gate Threshold Voltage | V _{GS(TH)} | V _{DS} =V _{GS} , I _D =250μA | 2.5 | | 4.5 | V |
| Static Drain-Source On-State Resistance | R _{DS(ON)} | V _{GS} =10V, I _D =2.5A | | | 1.5 | Ω |
| DYNAMIC CHARACTERISTICS | | | | | | |
| Input Capacitance | C _{ISS} | V _{GS} =0V, V _{DS} =25V, f=1.0MHz | | 286 | | pF |
| Output Capacitance | C _{OSS} | | | 150 | | pF |
| Reverse Transfer Capacitance | C _{RSS} | | | 15 | | pF |
| SWITCHING CHARACTERISTICS | | | | | | |
| Total Gate Charge (Note 1) | Q _G | V _{DS} =50V, V _{GS} =10V, I _D =1.3A, I _G =100μA (Note 1, 2) | | 37 | | nC |
| Gate to Source Charge | Q _{GS} | | | 3 | | nC |
| Gate to Drain Charge | Q _{GD} | | | 10.5 | | nC |
| Turn-ON Delay Time (Note 1) | t _{D(ON)} | V _{DD} =30V, V _{GS} =10V, I _D =0.5A, R _G =25Ω (Note 1, 2) | | 45 | | ns |
| Rise Time | t _R | | | 76 | | ns |
| Turn-OFF Delay Time | t _{D(OFF)} | | | 135 | | ns |
| Fall-Time | t _F | | | 35 | | ns |
| SOURCE- DRAIN DIODE RATINGS AND CHARACTERISTICS | | | | | | |
| Maximum Body-Diode Continuous Current | I _S | | | | 5 | A |
| Maximum Body-Diode Pulsed Current | I _{SM} | | | | 20 | A |
| Drain-Source Diode Forward Voltage (Note 1) | V _{SD} | I _S =5.0A, V _{GS} =0V | | | 1.4 | V |
| Body Diode Reverse Recovery Time (Note 1) | t _{rr} | I _S =5.0A, V _{GS} =0V, dI _F /dt=100A/μs | | 292 | | ns |
| Body Diode Reverse Recovery Charge | Q _{rr} | | | | 2.51 | |

Notes: 1. Pulse Test: Pulse width ≤ 300μs, Duty cycle ≤ 2%.

2. Essentially independent of operating temperature.

■ TEST CIRCUITS AND WAVEFORMS

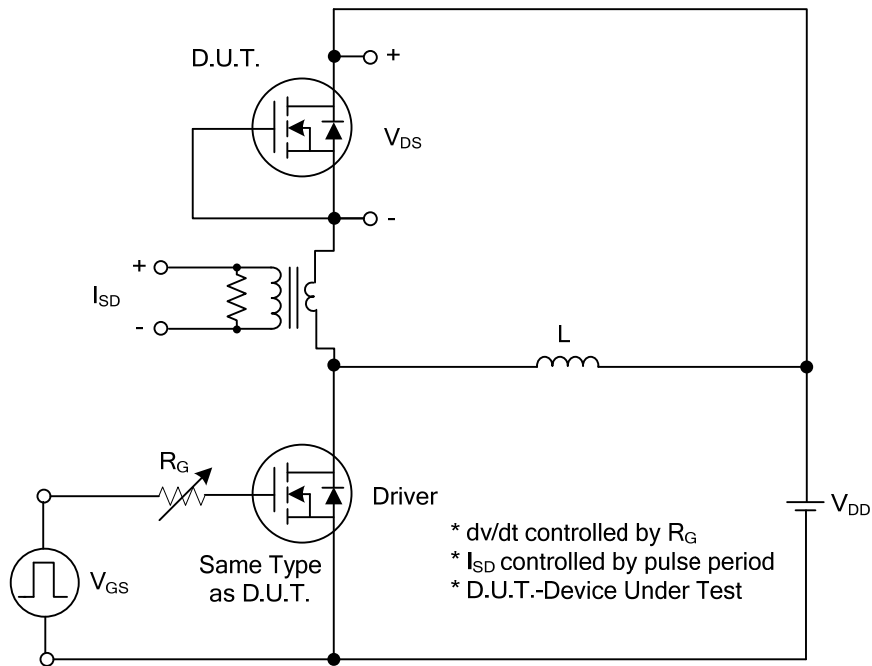

Peak Diode Recovery dv/dt Test Circuit

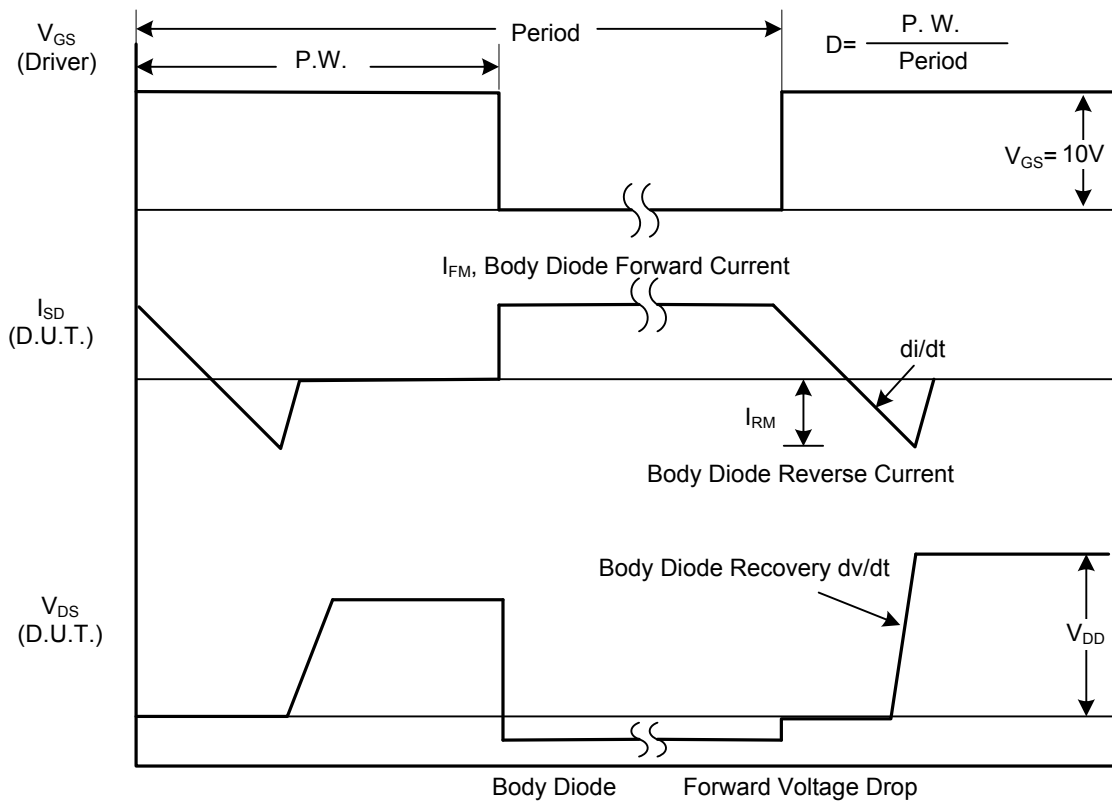

Peak Diode Recovery dv/dt Waveforms

■ TEST CIRCUITS AND WAVEFORMS (Cont.)

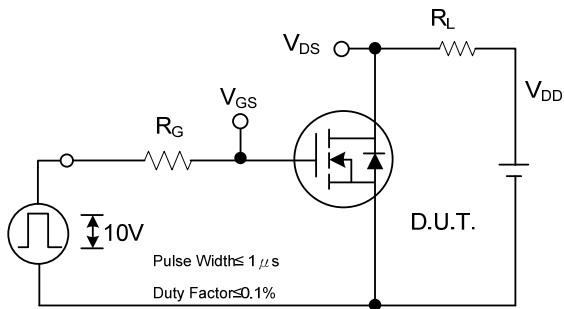

Switching Test Circuit

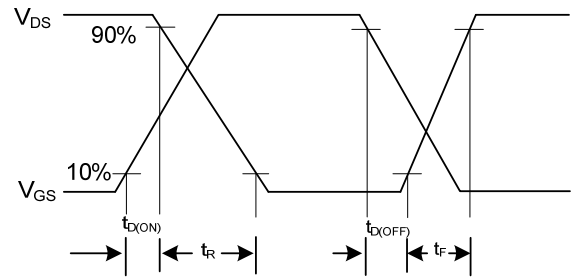

Switching Waveforms

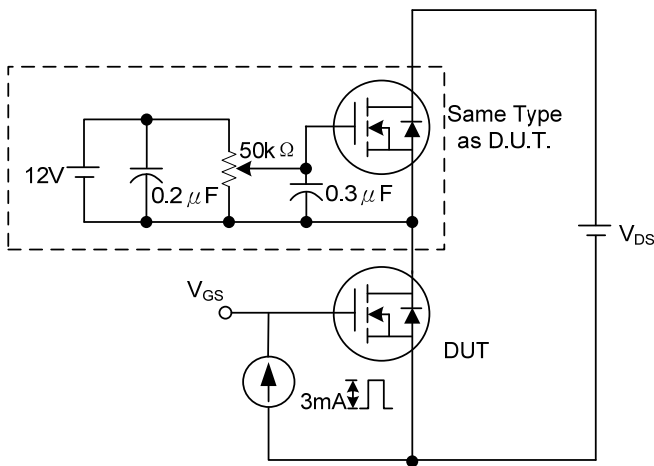

Gate Charge Test Circuit

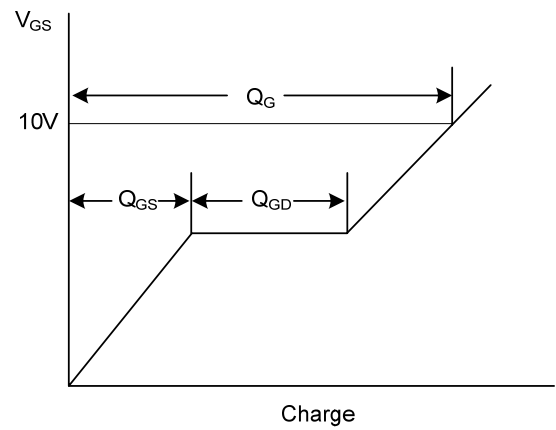

Gate Charge Waveform

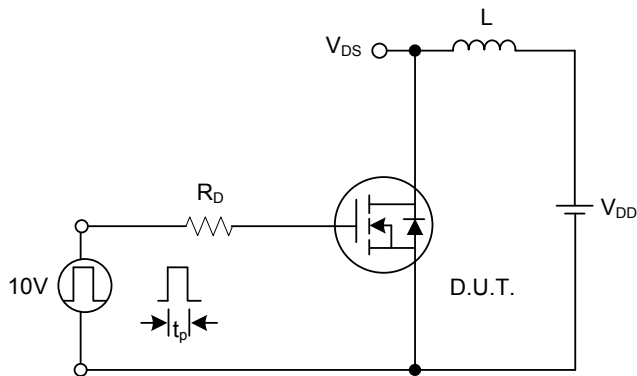

Unclamped Inductive Switching Test Circuit

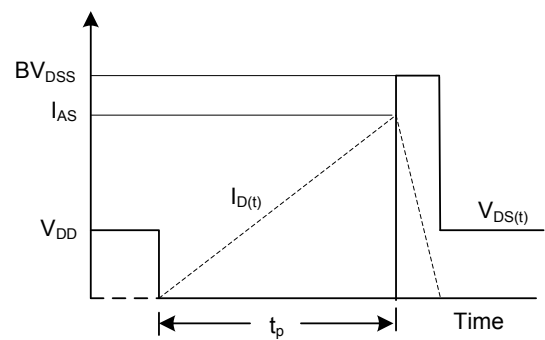

Unclamped Inductive Switching Waveforms

UTC assumes no responsibility for equipment failures that result from using products at values that exceed, even momentarily, rated values (such as maximum ratings, operating condition ranges, or other parameters) listed in products specifications of any and all UTC products described or contained herein. UTC products are not designed for use in life support appliances, devices or systems where malfunction of these products can be reasonably expected to result in personal injury. Reproduction in whole or in part is prohibited without the prior written consent of the copyright owner. The information presented in this document does not form part of any quotation or contract, is believed to be accurate and reliable and may be changed without notice.