



### 0.5A, 250V N-CHANNEL POWER MOSFET

#### DESCRIPTION

The UTC UF05N25 is a high voltage power MOSFET and is designed to have better characteristics, such as fast switching time, low gate charge, low on-state resistance and have a high rugged avalanche characteristics. This power MOSFET is usually used at high speed switching applications in power supplies, PWM motor controls, high efficient AC to DC converters and bridge circuits.

#### FEATURES

- \*  $R_{DS(ON)} \leq 3.5\Omega$  @  $V_{GS}=10V, I_D=0.25A$
- \* High switching speed
- \* 100% avalanche tested

#### SYMBOL

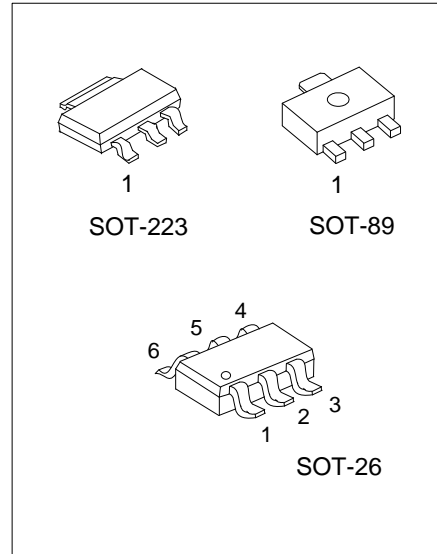
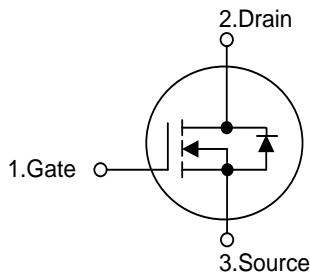

#### ORDERING INFORMATION

Ordering Number		Package	Pin Assignment						Packing
Lead Free	Halogen-Free		1	2	3	4	5	6	
UF05N25L-AA3-R	UF05N25G-AA3-R	SOT-223	G	D	S				Tape Reel
UF05N25L-AB3-R	UF05N25G-AB3-R	SOT-89	G	D	S	-	-	-	Tape Reel
UF05N25L-AG6-R	UF05N25G-AG6-R	SOT-26	D	D	G	S	D	D	Tape Reel

Note: Pin Assignment: G: Gate D: Drain S: Source

<p>UF05N25G-AA3-R</p> <p>(1)Packing Type (2)Package Type (3)Green Package</p>	<p>(1) R: Tape Reel (2) AA3: SOT-223, AB3: SOT-89, AG6: SOT-26 (3) G: Halogen Free and Lead Free, L: Lead Free</p>
---	--

■ MARKING

SOT-89	SOT-223	SOT-26
<p>             □□□□              UF05N25              1         </p> <p>             → Date Code              → L: Lead Free              → G: Halogen Free         </p>	<p>             UF05N25              □□□□              1         </p> <p>             → L: Lead Free              → G: Halogen Free              → Date Code         </p>	<p>             6 5 4              □ □ □              05N25              •              1 2 3         </p>

**■ ABSOLUTE MAXIMUM RATINGS** ( $T_A = 25^\circ\text{C}$ , unless otherwise specified)

PARAMETER	SYMBOL	RATINGS	UNIT
Drain-Source Voltage	$V_{DSS}$	250	V
Gate-Source Voltage	$V_{GSS}$	$\pm 20$	V
Continuous Drain Current	Continuous	$I_D$	0.5
	Pulsed	$I_{DM}$	2.0
Avalanche Current (Note 2)	$I_{AR}$	0.75	A
Avalanche Energy	$E_{AS}$	15.47	mJ
Peak Diode Recovery dv/dt (Note 4)	dv/dt	1.4	V/ns
Power Dissipation	SOT-223	$P_D$	2.5
	SOT-89		1.6
	SOT-26		0.6
Junction Temperature	$T_J$	+150	$^\circ\text{C}$
Storage Temperature Range	$T_{STG}$	-55 ~ +150	$^\circ\text{C}$

Notes: 1. Absolute maximum ratings are those values beyond which the device could be permanently damaged.

Absolute maximum ratings are stress ratings only and functional device operation is not implied.

2. Repetitive Rating: Pulse width limited by maximum junction temperature.

3.  $L=55\text{mH}$ ,  $I_{AS}=0.75\text{A}$ ,  $V_{DD}=50\text{V}$ ,  $R_G=25\ \Omega$ , Starting  $T_J = 25^\circ\text{C}$

4.  $I_{SD} \leq 0.5\text{A}$ ,  $di/dt \leq 200\text{A}/\mu\text{s}$ ,  $V_{DD} \leq BV_{DSS}$ , Starting  $T_J = 25^\circ\text{C}$

**■ THERMAL DATA (NOTE)**

PARAMETER	SYMBOL	RATINGS	UNIT
Junction to Ambient	$\theta_{JA}$	SOT-223	50
		SOT-89	78
		SOT-26	208
Junction to Case	$\theta_{JC}$	SOT-223	12.5
		SOT-89	15
		SOT-26	110

Note: Device mounted on FR-4 substrate  $P_C$  board, 2oz copper, with 1inch square copper plate.

**ELECTRICAL CHARACTERISTICS** ( $T_A=25^\circ\text{C}$ , unless otherwise specified)

PARAMETER	SYMBOL	TEST CONDITIONS	MIN	TYP	MAX	UNIT
<b>OFF CHARACTERISTICS</b>						
Drain-Source Breakdown Voltage	$BV_{DSS}$	$I_D=250\mu\text{A}$ , $V_{GS}=0\text{V}$	250			V
Drain-Source Leakage Current	$I_{DSS}$	$V_{DS}=250\text{V}$			1	$\mu\text{A}$
Gate-Source Leakage Current	Forward	$V_{GS}=+20\text{V}$ , $V_{DS}=0\text{V}$			10	$\mu\text{A}$
	Reverse		$V_{GS}=-20\text{V}$ , $V_{DS}=0\text{V}$			-10
<b>ON CHARACTERISTICS</b>						
Gate Threshold Voltage	$V_{GS(TH)}$	$I_D=250\mu\text{A}$	1.0		3.0	V
Static Drain-Source On-State Resistance	$R_{DS(ON)}$	$V_{GS}=10\text{V}$ , $I_D=0.25\text{A}$			3.5	$\Omega$
<b>DYNAMIC PARAMETERS</b>						
Input Capacitance	$C_{ISS}$	$V_{GS}=0\text{V}$ , $V_{DS}=25\text{V}$ , $f=1\text{MHz}$		120		pF
Output Capacitance	$C_{OSS}$			24.3		pF
Reverse Transfer Capacitance	$C_{RSS}$			10		pF
<b>SWITCHING PARAMETERS</b>						
Total Gate Charge (Note 1)	$Q_G$	$V_{GS}=10\text{V}$ , $V_{DS}=50\text{V}$ , $I_D=1.3\text{A}$ $I_G=100\mu\text{A}$ (Note 1, 2)		8		nC
Gate to Source Charge	$Q_{GS}$			0.3		nC
Gate to Drain Charge	$Q_{GD}$			1.2		nC
Turn-ON Delay Time (Note 1)	$t_{D(ON)}$	$V_{GS}=10\text{V}$ , $V_{DD}=30\text{V}$ , $R_G=25\Omega$ , $I_D=0.5\text{A}$ (Note 1, 2)		17		ns
Rise Time	$t_R$			24		ns
Turn-OFF Delay Time	$t_{D(OFF)}$			76		ns
Fall-Time	$t_F$			45		ns
<b>SOURCE- DRAIN DIODE RATINGS AND CHARACTERISTICS</b>						
Maximum Body-Diode Continuous Current	$I_S$				0.5	A
Maximum Body-Diode Pulsed Current	$I_{SM}$				2.0	A
Drain-Source Diode Forward Voltage (Note 1)	$V_{SD}$	$I_S=0.5\text{A}$			1.3	V
Body Diode Reverse Recovery Time (Note 1)	$t_{rr}$	$I_S=0.5\text{A}$ , $V_{GS}=0\text{V}$ , $dI_F/dt = 100\text{A}/\mu\text{s}$		95		ns
Body Diode Reverse Recovery Charge	$Q_{rr}$				110	

Notes: 1. Pulse Test: Pulse width  $\leq 300\mu\text{s}$ , Duty cycle  $\leq 2\%$ .

2. Essentially independent of operating temperature.

■ TEST CIRCUITS AND WAVEFORMS

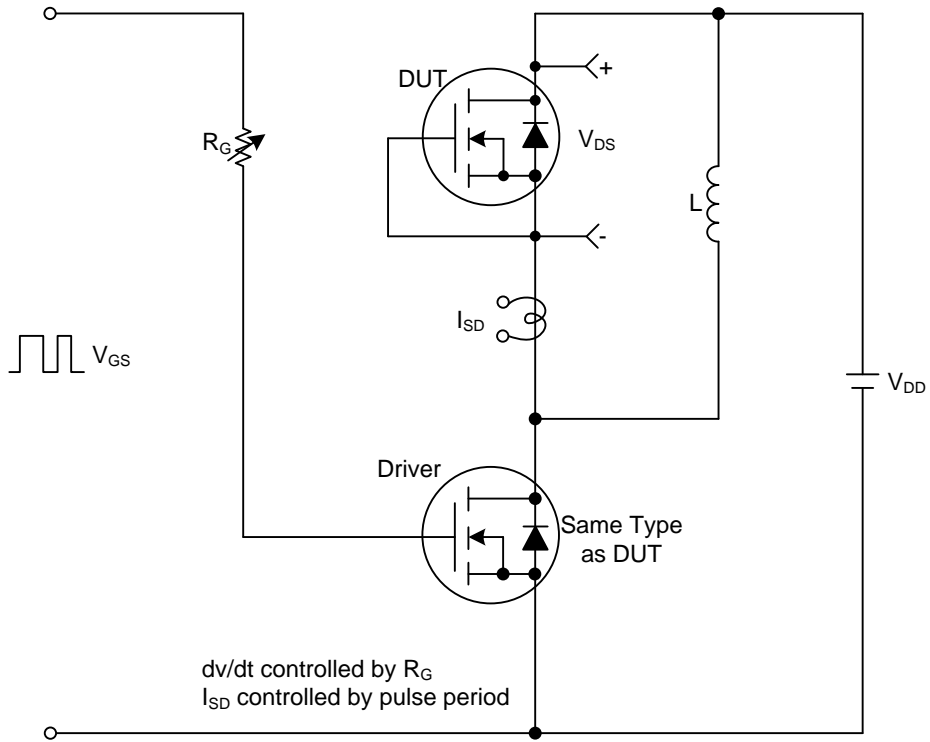

Peak Diode Recovery dv/dt Test Circuit

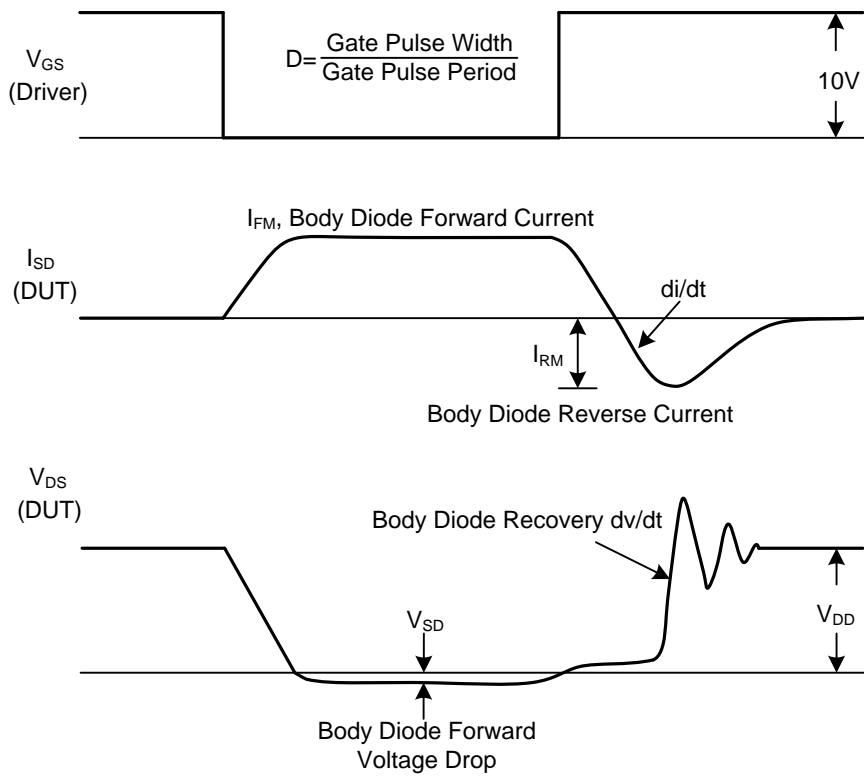

Peak Diode Recovery dv/dt Waveforms

■ TEST CIRCUITS AND WAVEFORMS

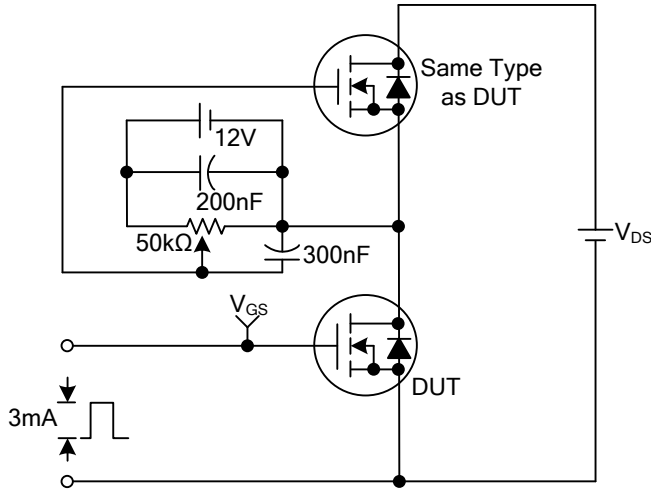

Gate Charge Test Circuit

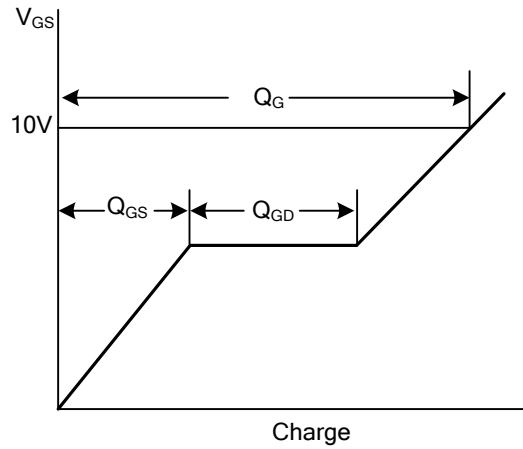

Gate Charge Waveforms

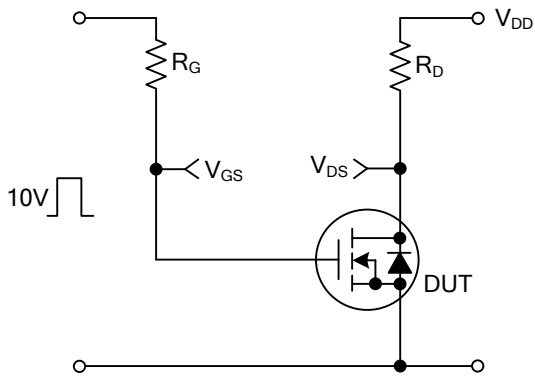

Resistive Switching Test Circuit

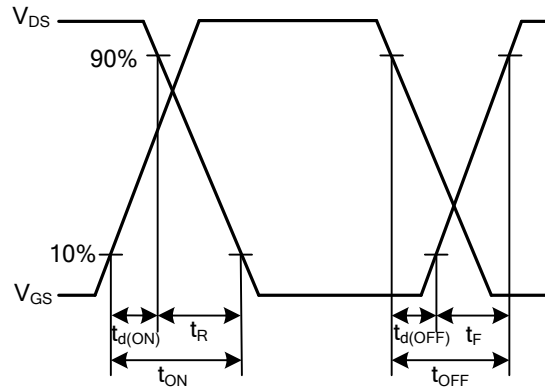

Resistive Switching Waveforms

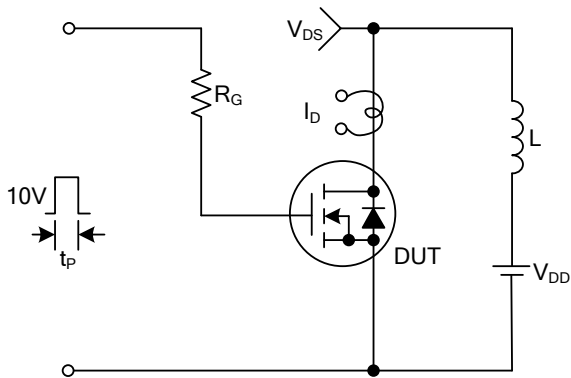

Unclamped Inductive Switching Test Circuit

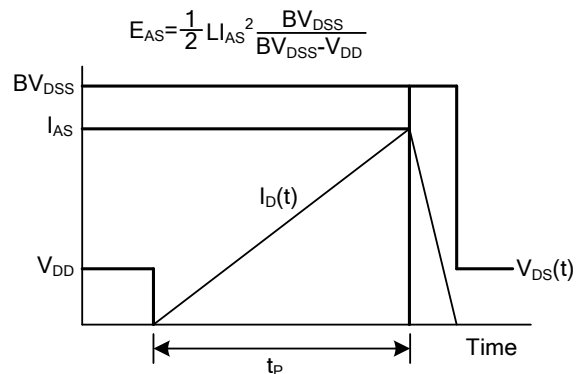

Unclamped Inductive Switching Waveforms

UTC assumes no responsibility for equipment failures that result from using products at values that exceed, even momentarily, rated values (such as maximum ratings, operating condition ranges, or other parameters) listed in products specifications of any and all UTC products described or contained herein. UTC products are not designed for use in life support appliances, devices or systems where malfunction of these products can be reasonably expected to result in personal injury. Reproduction in whole or in part is prohibited without the prior written consent of the copyright owner. UTC reserves the right to make changes to information published in this document, including without limitation specifications and product descriptions, at any time and without notice. This document supersedes and replaces all information supplied prior to the publication hereof.