



18N20

Preliminary

Power MOSFET

**18A, 200V, 0.20Ω,
N-CHANNEL POWER MOSFET**

■ **DESCRIPTION**

These kinds of n-channel power MOSFET field effect transistor have low conduction power loss, high input impedance, and high switching speed, Linear Transfer Characteristics, so can be use in a variety of power conversion applications.

The **18N20** suitable for resonant and PWM converter topologies.

■ **FEATURES**

- * $R_{DS(ON)} < 0.20\Omega @ V_{GS}=10V, I_D=9.0A$
- * Fast switching capability
- * Avalanche energy specified
- * Improved dv/dt capability, high ruggedness

■ **SYMBOL**

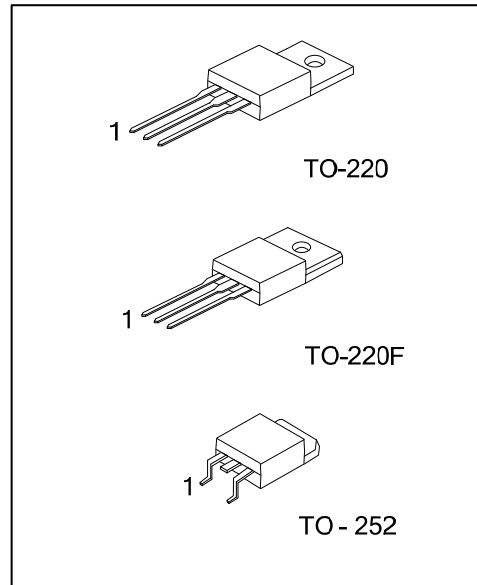
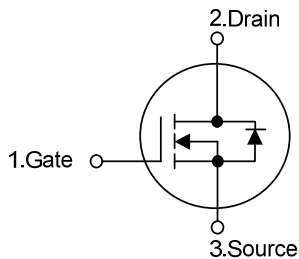

■ **ORDERING INFORMATION**

Ordering Number		Package	Pin Assignment			Packing
Lead Free	Halogen-Free		1	2	3	
18N20L-TA3-T	18N20G-TA3-T	TO-220	G	D	S	Tube
18N20L-TF3-T	18N20G-TF3-T	TO-220F	G	D	S	Tube
18N20L-TN3-R	18N20G-TN3-R	TO-252	G	D	S	Tape Reel

Note: Pin Assignment: G: Gate D: Drain S: Source

<p>18N20L-TA3-T</p>	<p>(1) T: Tube, R: Tape Reel (2) TA3: TO-220, TF3: TO-220F, TN3: TO-252 (3) L: Lead Free, G: Halogen Free and Lead Free</p>
---------------------	---

■ MARKING

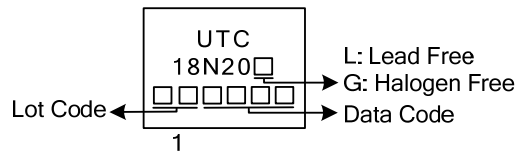

■ **ABSOLUTE MAXIMUM RATING** ($T_C = 25^\circ\text{C}$, unless otherwise specified)

PARAMETER	SYMBOL	RATINGS	UNIT
Drain-Source Voltage	V_{DSS}	200	V
Drain-Gate Voltage ($R_{GS}=20\text{k}\Omega$)	V_{DGR}	200	V
Gate-Source Voltage	V_{GSS}	± 20	V
Continuous Drain Current	I_D	18	A
Pulsed Drain Current (Note 2)	I_{DM}	72	A
Single Pulse Avalanche Energy Rating (Note 2)	E_{AS}	200	mJ
Peak Diode Recovery dv/dt (Note 4)	dv/dt	3.8	V/ns
Maximum Power Dissipation	TO-220	123	W
	TO-220F	40	W
	TO-252	83	W
Junction Temperature	T_J	+150	$^\circ\text{C}$
Storage Temperature	T_{STG}	-55 ~ +150	$^\circ\text{C}$

Notes: 1. Absolute maximum ratings are those values beyond which the device could be permanently damaged.

Absolute maximum ratings are stress ratings only and functional device operation is not implied.

2. Repetitive Rating: Pulse width limited by maximum junction temperature.

3. $L=1.2\text{mH}$, $V_{DD}=50\text{V}$, $R_G=25\Omega$, peak $I_{AS}=18\text{A}$, starting $T_J=25^\circ\text{C}$.

4. $I_{SD} \leq 18\text{A}$, $di/dt \leq 200\text{A}/\mu\text{s}$, $V_{DD} \leq BV_{DSS}$, Starting $T_J = 25^\circ\text{C}$.

■ **THERMAL RESISTANCES CHARACTERISTICS**

PARAMETER	SYMBOL	RATINGS	UNIT
Junction to Ambient	TO-220/TO-220F	62.5	$^\circ\text{C}/\text{W}$
	TO-252	110	$^\circ\text{C}/\text{W}$
Junction to Case	TO-220	1.01	$^\circ\text{C}/\text{W}$
	TO-220F	3.1	$^\circ\text{C}/\text{W}$
	TO-252	1.5	$^\circ\text{C}/\text{W}$

■ **ELECTRICAL CHARACTERISTICS** ($T_C = 25^\circ\text{C}$, unless otherwise specified)

PARAMETER	SYMBOL	TEST CONDITIONS	MIN	TYP	MAX	UNIT
OFF CHARACTERISTICS						
Drain-Source Breakdown Voltage	BV_{DSS}	$I_D=250\mu\text{A}$, $V_{GS}=0\text{V}$	200			V
Drain-Source Leakage Current	I_{DSS}	$V_{DS} = \text{Rated } BV_{DSS}$, $V_{GS} = 0\text{V}$			25	μA
Gate-Source Leakage Current	I_{GSS}	$V_{GS} = \pm 20\text{V}$			± 100	nA
ON CHARACTERISTICS						
Gate Threshold Voltage	$V_{GS(THR)}$	$V_{GS}=V_{DS}$, $I_D=250\mu\text{A}$	2		4	V
Drain-Source On Resistance	$R_{DS(ON)}$	$V_{GS}=10\text{V}$, $I_D=9.0\text{A}$			0.20	Ω
DYNAMIC PARAMETERS						
Input Capacitance	C_{ISS}	$V_{DS}=25\text{V}$, $V_{GS}=0\text{V}$, $f=1\text{MHz}$		805		pF
Output Capacitance	C_{OSS}			240		pF
Reverse Transfer Capacitance	C_{RSS}			46		pF
SWITCHING PARAMETERS						
Total Gate Charge	Q_G	$V_{GS}=10\text{V}$, $I_D=1.3\text{A}$, $V_{DS}=50\text{V}$, $I_G=100\mu\text{A}$		23		nC
Gate Source Charge	Q_{GS}			5.0		nC
Gate Drain Charge	Q_{GD}			8.8		nC
Turn-ON Delay Time	$t_{D(ON)}$	$V_{GS}=10\text{V}$, $I_D=0.5\text{A}$, $V_{DD}=10\text{V}$, $R_G=25\Omega$		40		ns
Turn-ON Rise Time	t_R			140		ns
Turn-OFF Delay Time	$t_{D(OFF)}$			112		ns
Turn-OFF Fall-Time	t_F			125		ns
SOURCE TO DRAIN DIODE SPECIFICATIONS						
Continuous Source Current (body diode)	I_S				18	A
Pulse Source Current (body diode) (Note)	I_{SM}				72	A
Diode Forward Voltage (Note)	V_{SD}	$T_J=25^\circ\text{C}$, $I_S=18\text{A}$, $V_{GS}=0\text{V}$,			2.0	V
Reverse Recovery Time	t_{rr}	$T_J=25^\circ\text{C}$, $I_S=18\text{A}$, $dI_S/dt=100\text{A}/\mu\text{s}$		170		ns
Reverse Recovery Charge	Q_{rr}	$T_J=25^\circ\text{C}$, $I_S=18\text{A}$, $dI_S/dt=100\text{A}/\mu\text{s}$		1.0		μC

Note: Pulse Test: Pulse width $\leq 300\mu\text{s}$, duty cycle $\leq 2\%$.

■ TEST CIRCUIT

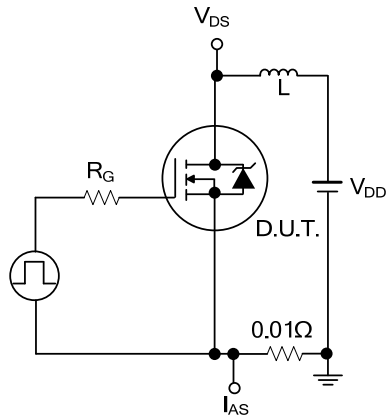

Fig. 1 Unclamped Energy Test Circuit

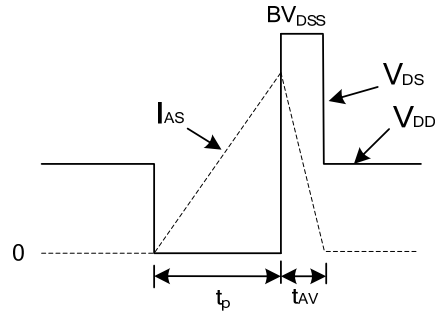

Fig.2 Unclamped Energy Waveforms

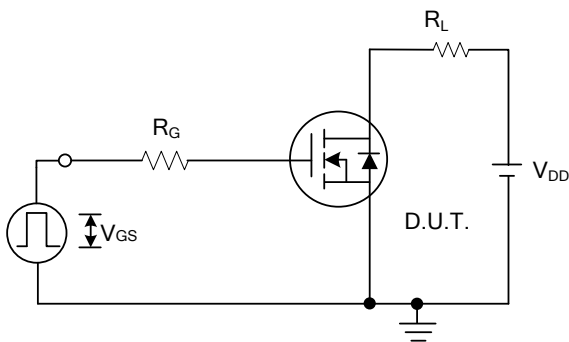

Fig.3 Switching Time Test Circuit

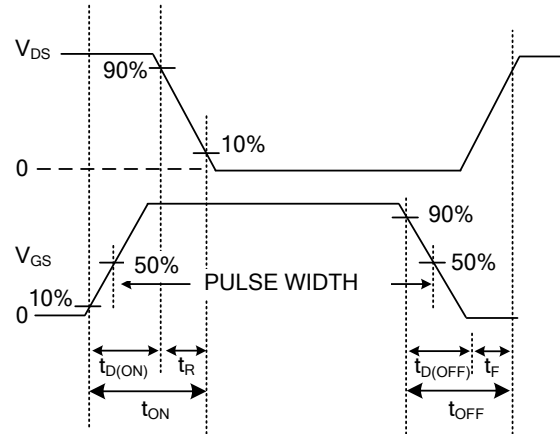

Fig.4 Resistive Switching Waveforms

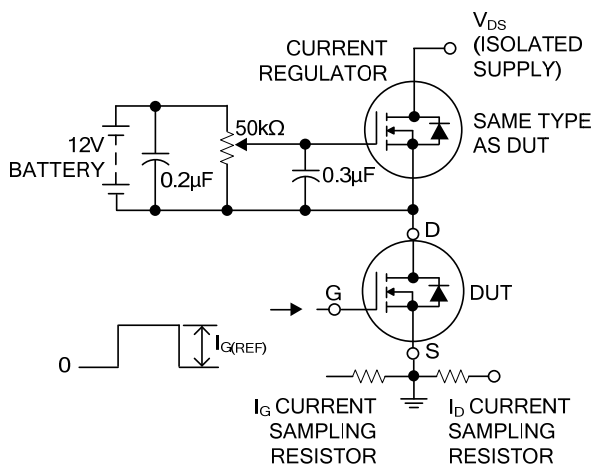

Fig.5 Gate Charge Test Circuit

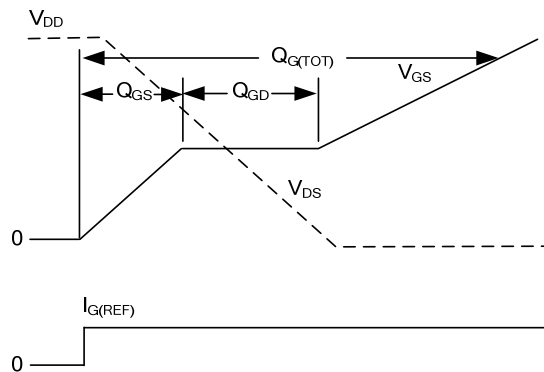

Fig.6 Gate Charge Waveforms

UTC assumes no responsibility for equipment failures that result from using products at values that exceed, even momentarily, rated values (such as maximum ratings, operating condition ranges, or other parameters) listed in products specifications of any and all UTC products described or contained herein. UTC products are not designed for use in life support appliances, devices or systems where malfunction of these products can be reasonably expected to result in personal injury. Reproduction in whole or in part is prohibited without the prior written consent of the copyright owner. The information presented in this document does not form part of any quotation or contract, is believed to be accurate and reliable and may be changed without notice.