



# 20NM60

Power MOSFET

## 20A, 600V N-CHANNEL SUPER-JUNCTION MOSFET

### DESCRIPTION

The **UTC 20NM60** is a Super Junction MOSFET Structure and is designed to have better characteristics, such as fast switching time, low gate charge, low on-state resistance and a high rugged avalanche characteristics. This power MOSFET is usually used at AC-DC converters for power applications.

### FEATURES

- \*  $R_{DS(ON)} \leq 0.21 \Omega @ V_{GS}=10V, I_D=10A$
- \* By using Super Junction Structure
- \* Fast Switching
- \* With 100% Avalanche Tested

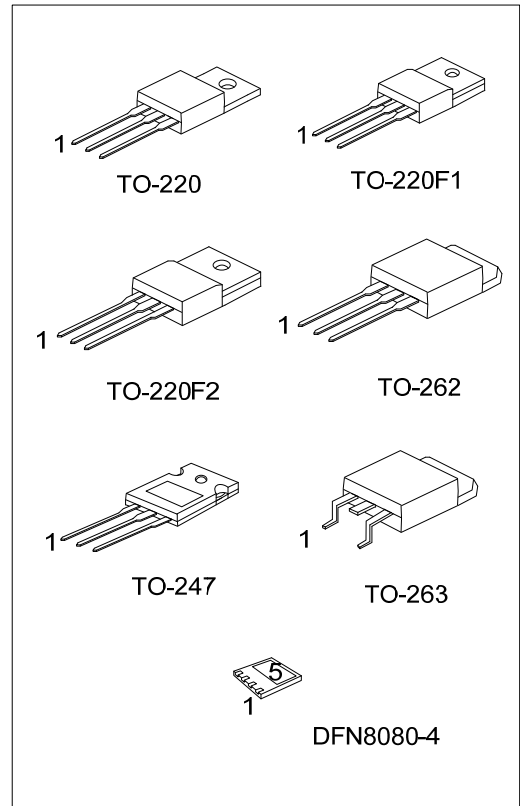

### SYMBOL

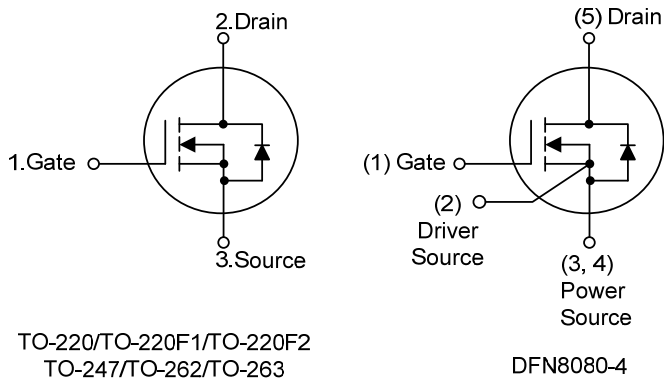

### ORDERING INFORMATION

Ordering Number		Package	Pin Assignment					Packing
Lead Free	Halogen Free		1	2	3	4	5	
20NM60L-TA3-T	20NM60G-TA3-T	TO-220	G	D	S	-	-	Tube
20NM60L-TF1-T	20NM60G-TF1-T	TO-220F1	G	D	S	-	-	Tube
20NM60L-TF2-T	20NM60G-TF2-T	TO-220F2	G	D	S	-	-	Tube
20NM60L-T2Q-T	20NM60G-T2Q-T	TO-262	G	D	S	-	-	Tube
20NM60L-TQ2-T	20NM60G-TQ2-T	TO-263	G	D	S	-	-	Tube
20NM60L-TQ2-R	20NM60G-TQ2-R	TO-263	G	D	S	-	-	Tape Reel
20NM60L-T47-T	20NM60G-T47-T	TO-247	G	D	S	-	-	Tube
20NM60L-K04-8080-R	20NM60G-K04-8080-R	DFN8080-4	G	S	S	S	D	Tape Reel

Note: Pin Assignment: G: Gate D: Drain S: Source

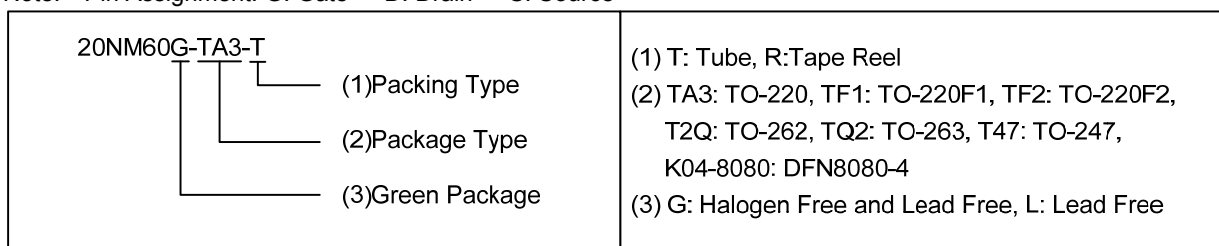

### MARKING

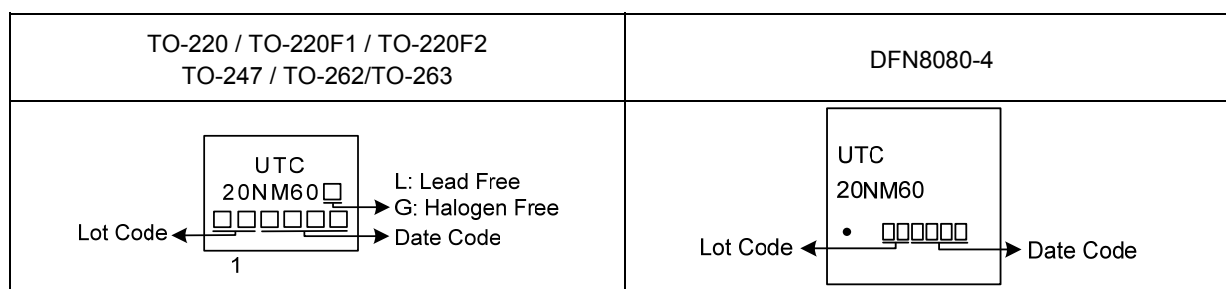

■ ABSOLUTE MAXIMUM RATINGS ( $T_C=25^\circ\text{C}$ , unless otherwise specified)

PARAMETER		SYMBOL	RATINGS	UNIT	
Drain-Source Voltage		$V_{DSS}$	600	V	
Gate-Source Voltage		$V_{GSS}$	$\pm 30$	V	
Continuous Drain Current	Continuous	$I_D$	$T_C=25^\circ\text{C}$	20	A
			$T_C=100^\circ\text{C}$	13	A
Pulsed Drain Current	Pulsed (Note 2)	$I_{DM}$	60	A	
Avalanche energy	Single Pulsed (Note 3)	$E_{AS}$	265	mJ	
Peak Diode Recovery dv/dt (Note 4)		dv/dt	2.8	V/nS	
Power Dissipation	TO-220/TO-262/TO-263	$P_D$	114	W	
	TO-220F1/TO-220F2		34	W	
	TO-247		130	W	
	DFN8080-4		63.5	W	
Junction Temperature		$T_J$	+150	$^\circ\text{C}$	
Storage Temperature Range		$T_{STG}$	-55 ~ +150	$^\circ\text{C}$	

Notes: 1. Absolute maximum ratings are those values beyond which the device could be permanently damaged.

Absolute maximum ratings are stress ratings only and functional device operation is not implied.

2. Repetitive Rating: Pulse width limited by maximum junction temperature.

3.  $L=30\text{mH}$ ,  $I_{AS}=4.2\text{A}$ ,  $V_{DD}=50\text{V}$ ,  $R_G=25\Omega$ , Starting  $T_J = 25^\circ\text{C}$ .

4.  $I_{SD} \leq 10\text{A}$ ,  $di/dt \leq 200\text{A}/\mu\text{s}$ ,  $V_{DD} \leq V_{(BR)DSS}$ ,  $T_J = 25^\circ\text{C}$ .

■ THERMAL DATA

PARAMETER		SYMBOL	RATINGS	UNIT
Junction to Ambient	TO-220/TO-220F1 TO-220F2/TO-262 TO-263	$\theta_{JA}$	62.5	$^\circ\text{C}/\text{W}$
	TO-247		40	$^\circ\text{C}/\text{W}$
	DFN8080-4		35 (Note)	$^\circ\text{C}/\text{W}$
Junction to Case	TO-220/TO-262 TO-263	$\theta_{JC}$	1.09	$^\circ\text{C}/\text{W}$
	TO-220F1/TO-220F2		3.67	$^\circ\text{C}/\text{W}$
	TO-247		0.96	$^\circ\text{C}/\text{W}$
	DFN8080-4		1.95 (Note)	$^\circ\text{C}/\text{W}$

Note: Device mounted on FR-4 substrate PC board, 2oz copper, with 1inch square copper plate.

■ ELECTRICAL CHARACTERISTICS (T<sub>J</sub>=25°C, unless otherwise specified)

PARAMETER	SYMBOL	TEST CONDITIONS	MIN	TYP	MAX	UNIT
<b>OFF CHARACTERISTICS</b>						
Drain-Source Breakdown Voltage	BV <sub>DSS</sub>	V <sub>GS</sub> =0V, I <sub>D</sub> =250μA	600			V
Drain-Source Leakage Current	I <sub>DSS</sub>	V <sub>DS</sub> =600V, V <sub>GS</sub> =0V			10	μA
Gate-Source Leakage Current	Forward	V <sub>DS</sub> =0V, V <sub>GS</sub> =+30V			+100	nA
	Reverse		V <sub>DS</sub> =0V, V <sub>GS</sub> =-30V			-100
<b>ON CHARACTERISTICS</b>						
Gate Threshold Voltage	V <sub>GS(TH)</sub>	V <sub>DS</sub> = V <sub>GS</sub> , I <sub>D</sub> =250μA	2.5		4.5	V
Drain-Source On-State Resistance	R <sub>DS(ON)</sub>	V <sub>GS</sub> =10V, I <sub>D</sub> =10A			0.21	Ω
<b>DYNAMIC PARAMETERS</b>						
Input Capacitance	C <sub>ISS</sub>	V <sub>GS</sub> =0V, V <sub>DS</sub> =50V, f=1.0MHz		1300		pF
Output Capacitance	C <sub>OSS</sub>			145		pF
Reverse Transfer Capacitance	C <sub>RSS</sub>			5		pF
<b>SWITCHING PARAMETERS</b>						
Total Gate Charge (Note 1)	Q <sub>G</sub>	V <sub>DS</sub> =480V, V <sub>GS</sub> =10V, I <sub>D</sub> =20A, I <sub>G</sub> =1mA (Note 1, 2)		47		nC
Gate to Source Charge	Q <sub>GS</sub>			12		nC
Gate to Drain Charge	Q <sub>GD</sub>			20		nC
Turn-on Delay Time (Note 1)	t <sub>D(ON)</sub>	V <sub>DD</sub> =100V, V <sub>GS</sub> =10V, I <sub>D</sub> =20A, R <sub>G</sub> =25Ω (Note 1, 2)		20		ns
Rise Time	t <sub>R</sub>			28		ns
Turn-off Delay Time	t <sub>D(OFF)</sub>			146		ns
Fall-Time	t <sub>F</sub>			57		ns
<b>SOURCE- DRAIN DIODE RATINGS AND CHARACTERISTICS</b>						
Maximum Body-Diode Pulsed Current	I <sub>S</sub>				20	A
Drain-Source Diode Forward Voltage (Note 1)	I <sub>SM</sub>				60	A
Maximum Body-Diode Continuous Current	V <sub>SD</sub>	I <sub>S</sub> =20A, V <sub>GS</sub> =0V			1.4	V
Reverse Recovery Time (Note 1)	t <sub>rr</sub>	I <sub>S</sub> =20A, V <sub>GS</sub> =0V, dI <sub>F</sub> /dt=100A/μs		421		ns
Reverse Recovery Charge	Q <sub>rr</sub>				7.5	

Note: 1. Pulse Test: Pulse width ≤ 300μs, Duty cycle ≤ 2%.

2. Essentially independent of operating temperature.

■ TEST CIRCUITS AND WAVEFORMS

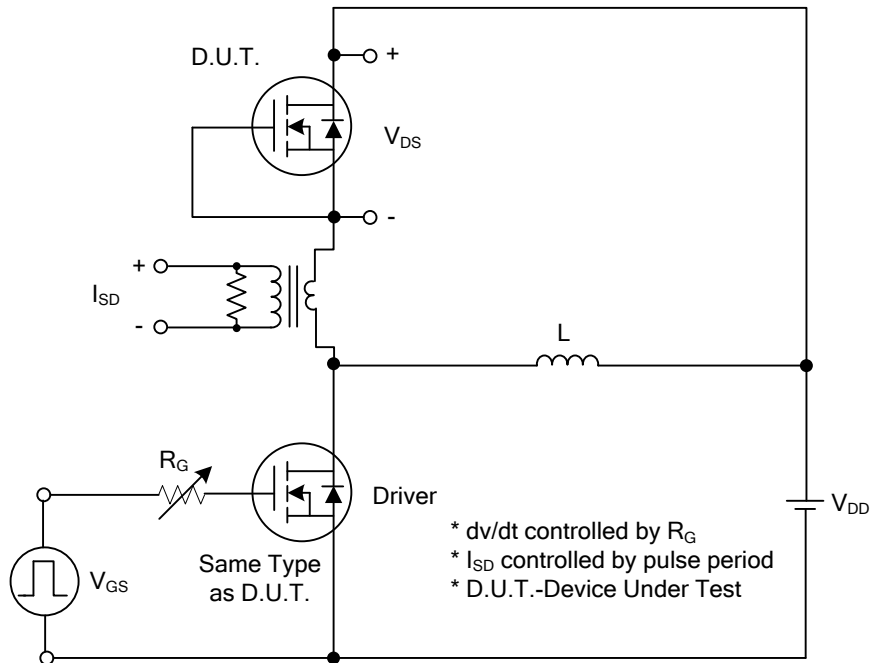

Peak Diode Recovery  $dv/dt$  Test Circuit

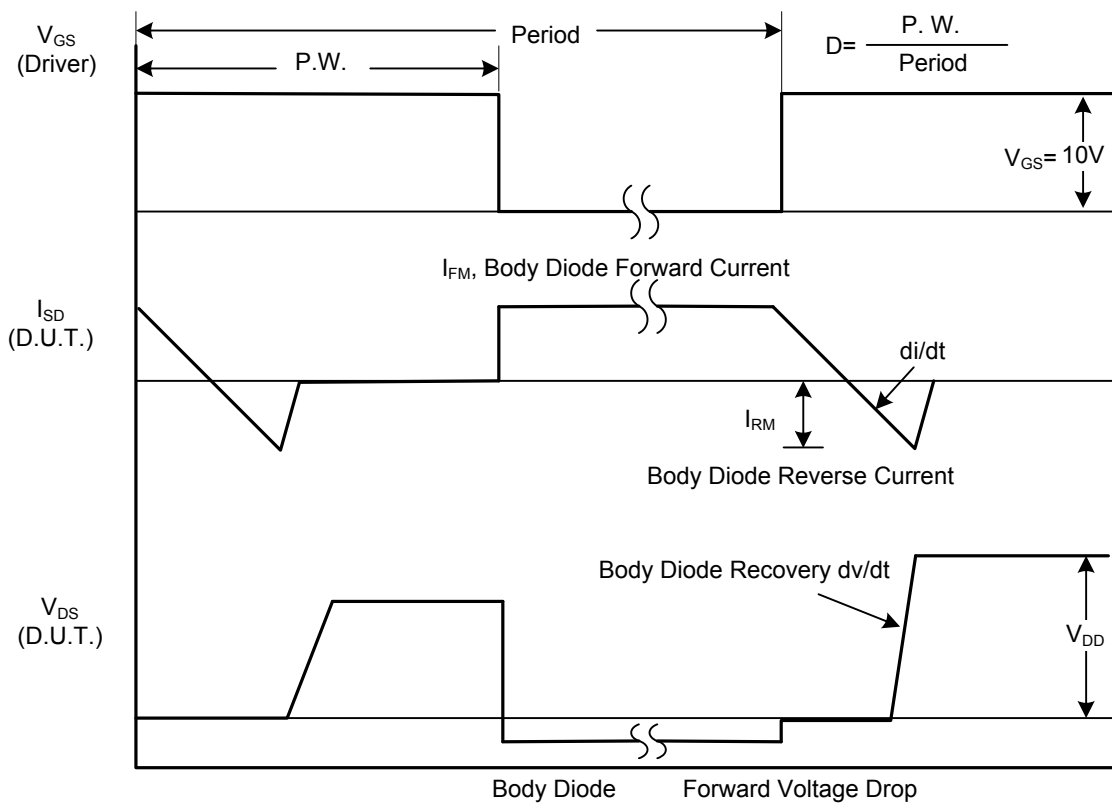

Peak Diode Recovery  $dv/dt$  Waveforms

■ TEST CIRCUITS AND WAVEFORMS

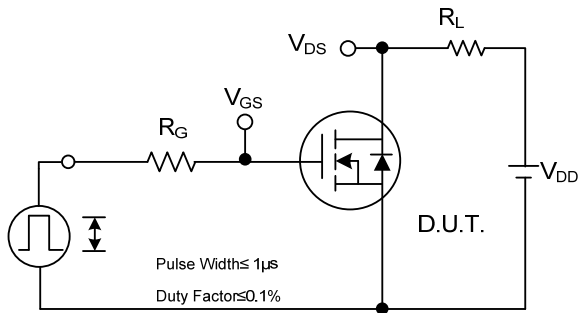

Switching Test Circuit

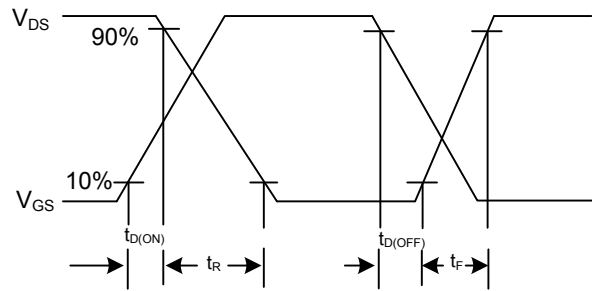

Switching Waveforms

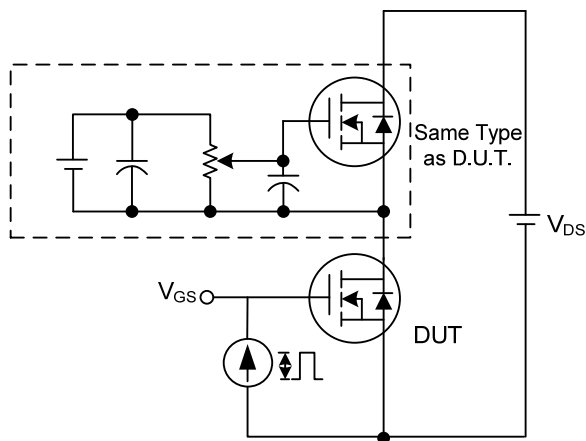

Gate Charge Test Circuit

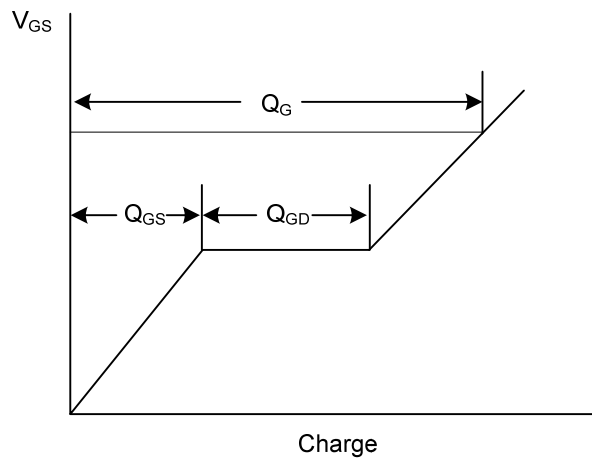

Gate Charge Waveform

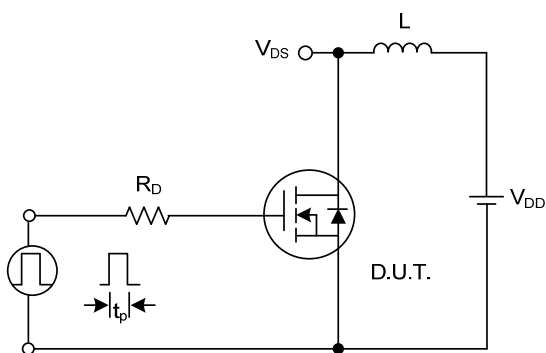

Unclamped Inductive Switching Test Circuit

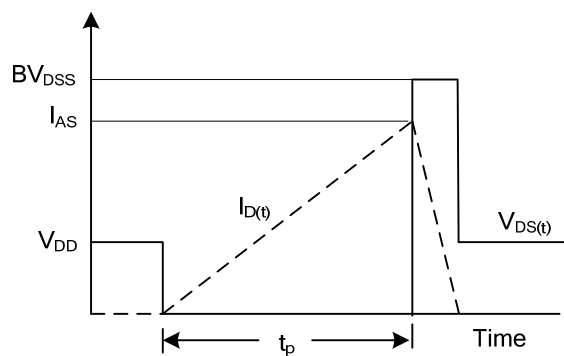

Unclamped Inductive Switching Waveforms

## ■ TYPICAL CHARACTERISTICS

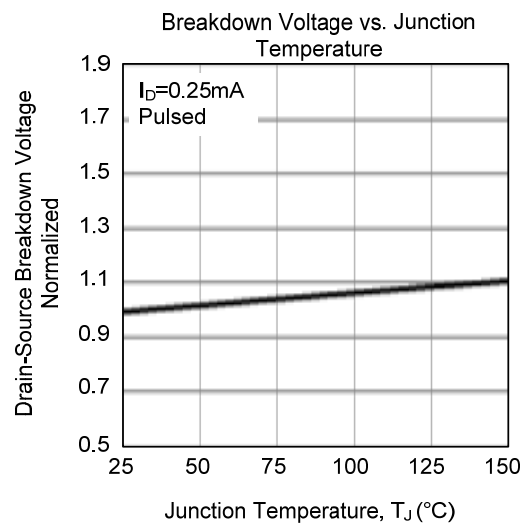
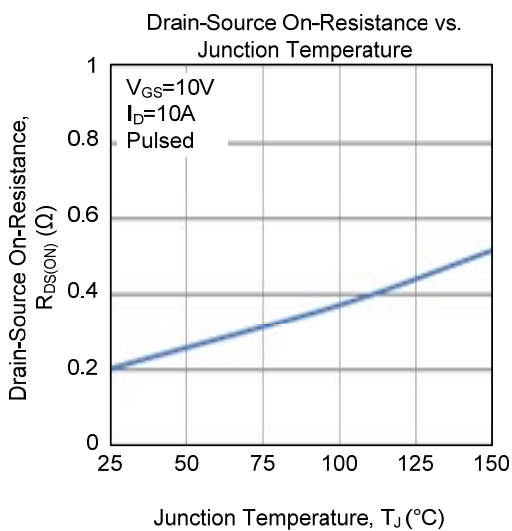
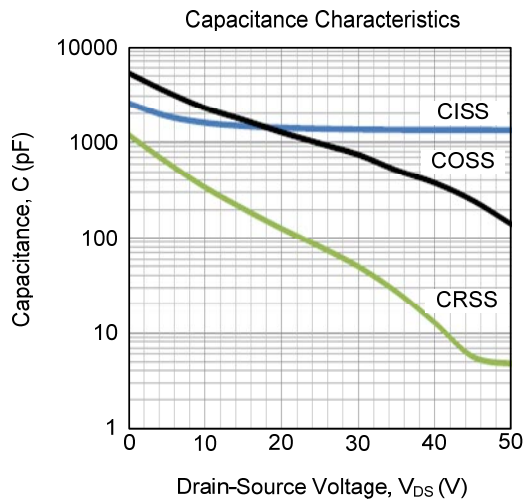
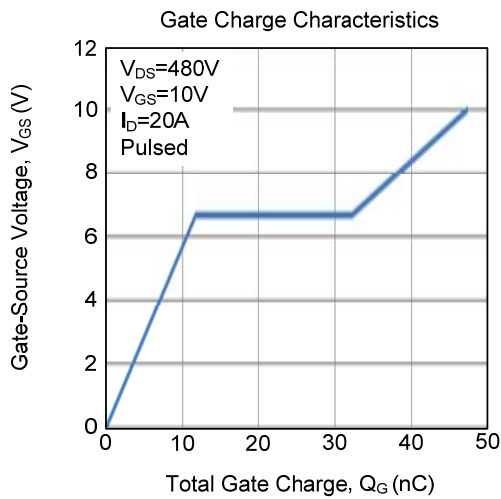
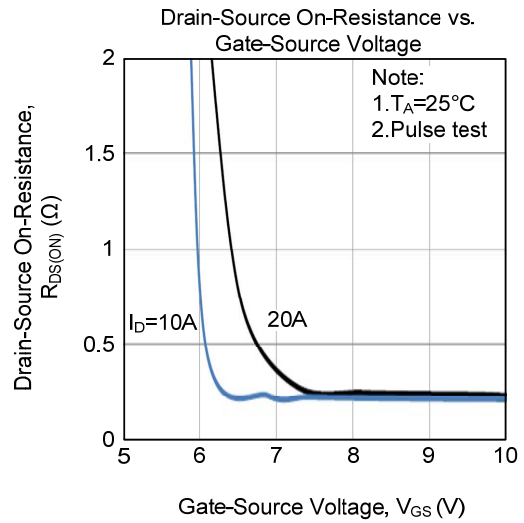
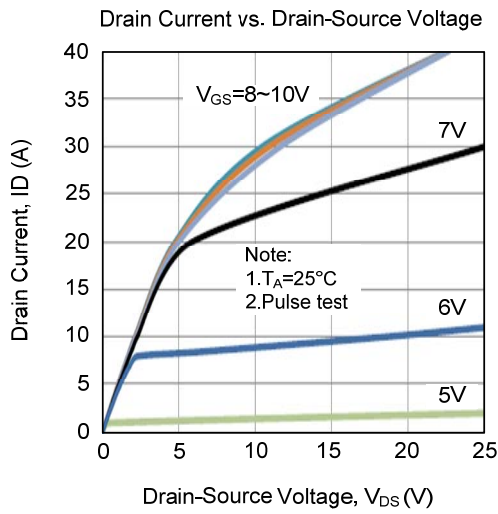

## ■ TYPICAL CHARACTERISTICS (Cont.)

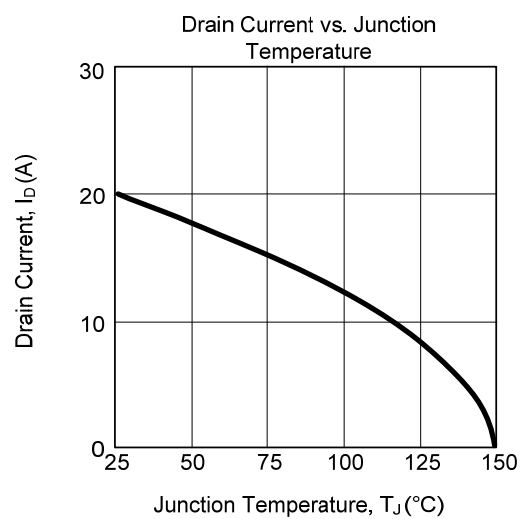
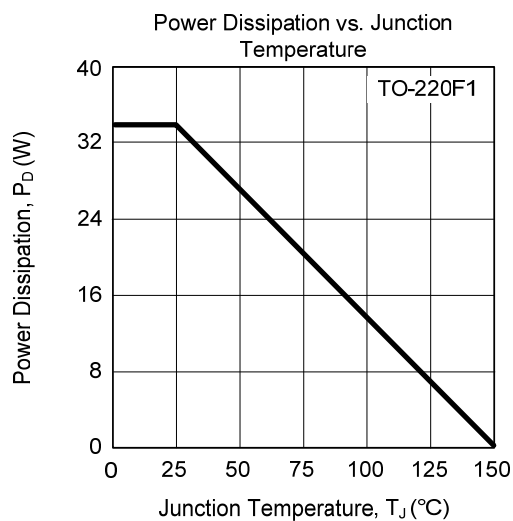
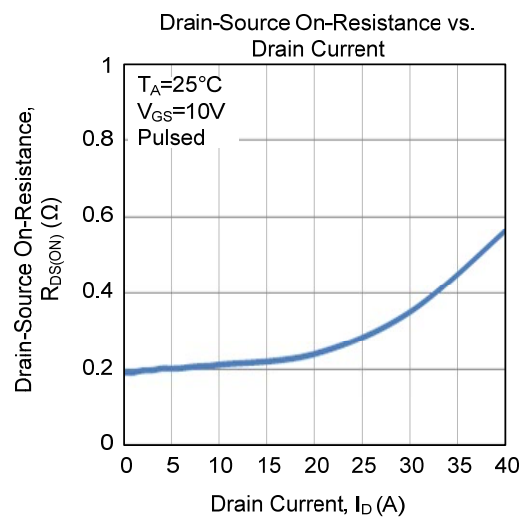
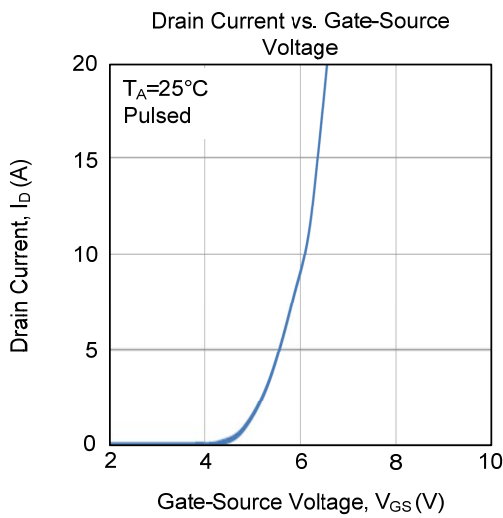
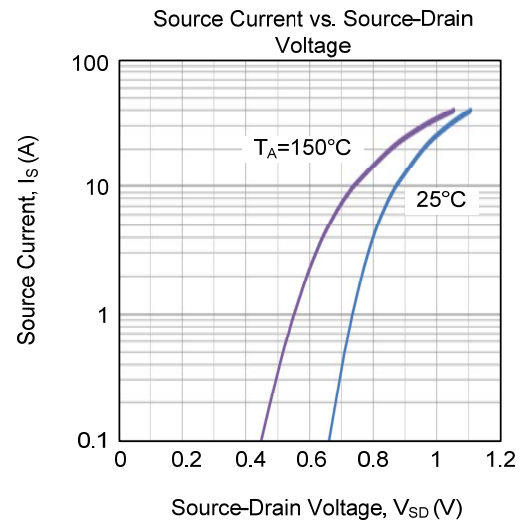
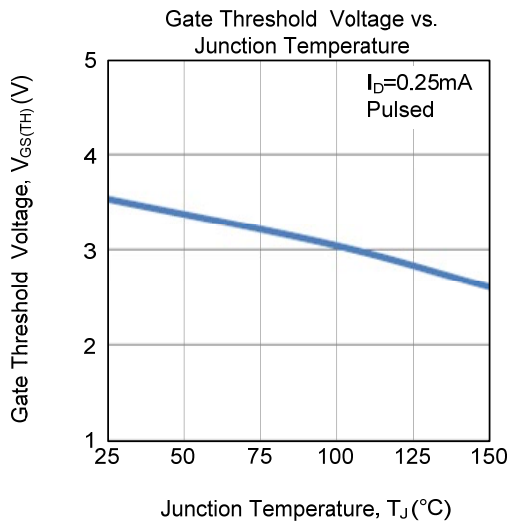



■ TYPICAL CHARACTERISTICS (Cont.)

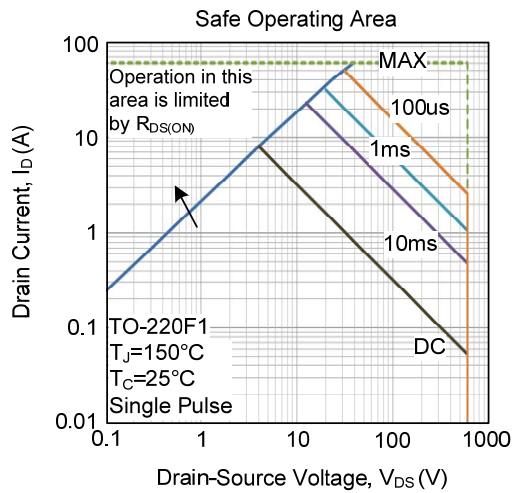

UTC assumes no responsibility for equipment failures that result from using products at values that exceed, even momentarily, rated values (such as maximum ratings, operating condition ranges, or other parameters) listed in products specifications of any and all UTC products described or contained herein. UTC products are not designed for use in life support appliances, devices or systems where malfunction of these products can be reasonably expected to result in personal injury. Reproduction in whole or in part is prohibited without the prior written consent of the copyright owner. UTC reserves the right to make changes to information published in this document, including without limitation specifications and product descriptions, at any time and without notice. This document supersedes and replaces all information supplied prior to the publication hereof.