



## LR1812

Preliminary

CMOS IC

### 1.0A FAST ULTRA LOW DROPOUT LINEAR REGULATOR WITH REVERSE CURRENT PROTECTION

#### DESCRIPTION

The UTC **LR1812** operate from a +1.5V ~ +6V input supply as fast ultra low-dropout linear regulators. Wide output voltage range options are available. The fast response characteristic to make UTC **LR1812** suitable for low voltage microprocessor application. The low quiescent current operation and low dropout quality caused by the CMOS process.

The UTC **LR1812** has low dropout voltage. The ground pin current is typically 60uA.

Output Voltage Precision: Multiple output voltage options are available and ranging from 1.2V ~ 5.0V at room temperature with a guaranteed accuracy of ±1.5%, and ±3.0% when varying line and load.

With the reverse current protection function of a driver transistor, the reverse current flow is prohibited when V<sub>OUT</sub> voltage is higher than V<sub>IN</sub> voltage. For an example, when a battery is connected to the V<sub>OUT</sub> pin, battery current will not flow back to the UTC **LR1812**

The output voltage types of UTC **LR1812-xx** are fixed one in the IC.

#### FEATURES

- \* Low Dropout Voltage
- \* The Guaranteed Output Current is 1A DC
- \* Output Voltage Accuracy ± 1.5%
- \* Over temperature Protection And Over current Protection
- \* Reverse Current Protection

#### ORDERING INFORMATION

| Ordering Number    |                    | Package | Packing   |
|--------------------|--------------------|---------|-----------|
| Lead Free          | Halogen Free       |         |           |
| LR1812L-xx-AB3-C-R | LR1812G-xx-AB3-C-R | SOT-89  | Tape Reel |
| LR1812L-xx-AF5-R   | LR1812G-xx-AF5-R   | SOT-25  | Tape Reel |
| LR1812L-xx-SH2-R   | LR1812G-xx-SH2-R   | HSOP-8  | Tape Reel |

Note: xx: Output Voltage, refer to Marking Information.

|  |   |
|--|---|
| <p>LR1812G-xx-AB3-C-R</p> <p>(1)Packing Type<br/>(2)Pin Assignment<br/>(3)Package Type<br/>(4)Output Voltage Code<br/>(5)Green Package</p> | <p>(1) R: Tape Reel<br/>(2) refer to PIN CONFIGURATION<br/>(3) AB3: SOT-89, AF5: SOT-25, SH2: HSOP-8<br/>(4) xx: refer to Marking Information<br/>(5) G: Halogen Free and Lead Free, L: Lead Free</p> |
|--|---|

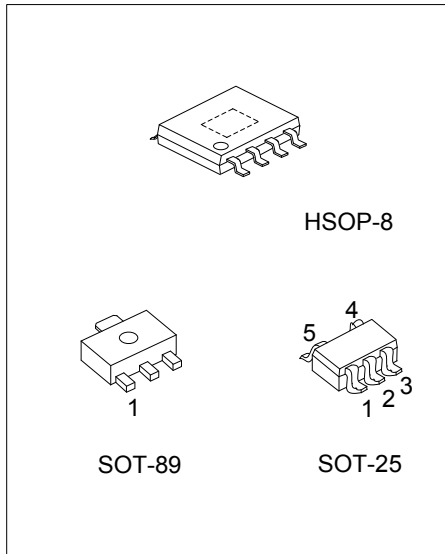

### MARKING INFORMATION

| PACKAGE | VOLTAGE CODE   | MARKING |
|---------|--|---------|
| SOT-89  | 12: 1.2V<br>15: 1.5V<br>18: 1.8V<br>25: 2.5V<br>33: 3.3V<br>36: 3.6V |         |
| SOT-25  |  |         |
| HSOP-8  |  |         |

### PIN CONFIGURATION

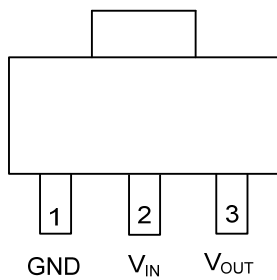

SOT-89

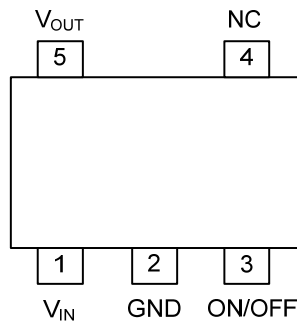

SOT-25

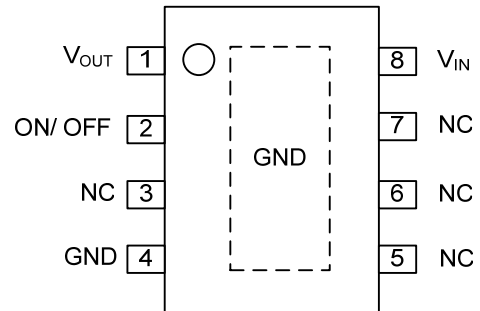

HSOP-8

### PIN DESCRIPTION

| PIN NO. |        |                | PIN NAME  | DESCRIPTION   |
|---------|--------|----------------|-----------|---|
| SOT-89  | SOT-25 | HSOP-8 (Fixed) |           |   |
| 1       | 2      | 4              | GND       | GND   |
| 2       | 1      | 8              | $V_{IN}$  | Input voltage   |
| 3       | 3      | 2              | ON/OFF    | ON/OFF select pin, when connected to the ground the chip in operating normally. |
| -       | 4      | 3, 5, 6, 7     | NC        | No connection   |
| -       | 5      | 1              | $V_{OUT}$ | Output voltage  |

Note: The NC pin is electrically open.  
 The NC pin can be connected to  $V_{IN}$  or GND.

■ BLOCK DIAGRAM

Fixed Output Voltage

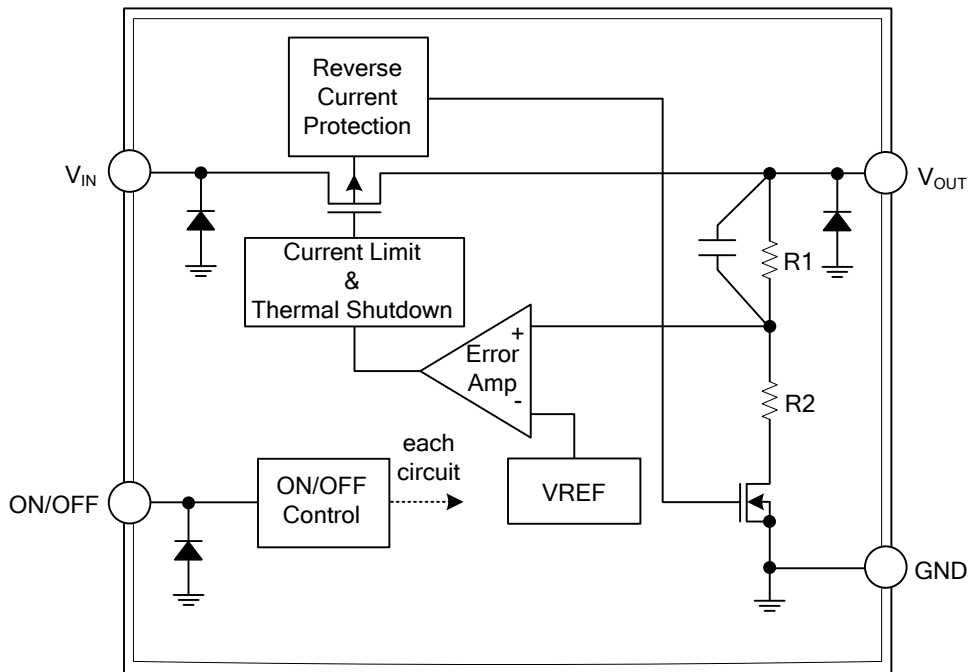

### ■ ABSOLUTE MAXIMUM RATINGS

| PARAMETER                      | SYMBOL         | RATINGS            | UNIT |
|--------------------------------|----------------|--------------------|------|
| Input Voltage                  | $V_{IN}$       | 7                  | V    |
| Shutdown Input Voltage         | $V_{IN(SHDN)}$ | -0.3 ~ $V_{IN}$    | V    |
| Maximum Operating Current (DC) |                | 1                  | A    |
| Power Dissipation (Note 3)     | $P_D$          | Internally Limited |      |
| Junction Temperature           | $T_J$          | +125               | °C   |
| Storage Temperature            | $T_{STG}$      | -65 ~ +150         | °C   |

Note: Absolute maximum ratings are those values beyond which the device could be permanently damaged. Absolute maximum ratings are stress ratings only and functional device operation is not implied.

### ■ THERMAL DATA

| PARAMETER           | SYMBOL | RATINGS | UNIT |
|---------------------|--------|---------|------|
| Junction to Ambient | SOT-89 | 180     | °C/W |
|                     | SOT-25 | 255     | °C/W |
|                     | HSOP-8 | 143     | °C/W |
| Junction to Case    | SOT-89 | 50      | °C/W |
|                     | SOT-25 | 64      | °C/W |
|                     | HSOP-8 | 45      | °C/W |

### ■ ELECTRICAL CHARACTERISTICS ( $T_J = 25^\circ\text{C}$ , unless otherwise specified.)

#### For LR1812-xx

| PARAMETER                                      | SYMBOL   | TEST CONDITIONS  | MIN                              | TYP          | MAX                    | UNIT   |   |
|--|--|--|----------------------------------|--------------|------------------------|--------|---|
| Input Voltage                                  | $V_{IN}$   |  | 1.5                              |              | 6                      | V      |   |
| Output Voltage (Note 3)                        | $V_{OUT(E)}$   | $V_{IN}=V_{OUT(S)}+1V$<br>$I_{OUT}=100mA$<br>$1.0V \leq V_{OUT(S)} < 1.5V$                     | $V_{OUT(S)}$<br>-                | $V_{OUT(S)}$ | $V_{OUT(S)}$<br>+      | V      |   |
|  |  | $1.5V \leq V_{OUT(S)} \leq 3.5V$   | $V_{OUT(S)}$<br>x 0.99           | $V_{OUT(S)}$ | $V_{OUT(S)}$<br>x 1.01 | V      |   |
| Output Voltage Line Regulation                 | $\frac{\Delta V_{OUT1}}{(\Delta V_{IN} \times V_{OUT})}$ | $V_{OUT(S)}+0.5V \leq V_{IN} \leq 5.5V, I_{OUT}=100mA$   |                                  | 0.05         | 0.2                    | %/V    |   |
| Output Voltage Load Regulation                 | $\Delta V_{OUT2}$  | $V_{IN}=V_{OUT(S)}+1V, 1mA \leq I_{OUT} \leq 300mA$  | -20                              | -3           | 20                     | mV     |   |
| Dropout Voltage(Note 4)                        | $V_{drop}$   | $I_{OUT}=300mA$  | $1.2V \leq V_{OUT(S)} < 1.5V$    |              | 0.34                   | 0.45   | V |
|  |  |  | $1.5V \leq V_{OUT(S)} < 2.6V$    |              | 0.10                   | 0.18   |   |
|  |  |  | $2.6V \leq V_{OUT(S)} \leq 5.0V$ |              | 0.07                   | 0.12   |   |
|  |  | $I_{OUT}=1000mA$   | $1.2V \leq V_{OUT(S)} < 1.5V$    |              | 0.70                   |        |   |
|  |  |  | $1.5V \leq V_{OUT(S)} < 2.0V$    |              | 0.40                   |        |   |
|  |  |  | $2.0V \leq V_{OUT(S)} < 2.6V$    |              | 0.32                   |        |   |
|  |  | $2.6V \leq V_{OUT(S)} \leq 5.0V$   |                                  | 0.23         |                        |        |   |
|  |  |  |                                  |              |                        |        |   |
| Output Current(Note 5)                         | $I_{OUT}$  | $V_{IN} \geq V_{OUT(S)}+1V$  | 1000<br>(Note 7)                 |              |                        | mA     |   |
| Ground Pin Current In Normal Operation Mode    | $I_{SS1}$  | $V_{IN}=V_{OUT(S)}+1V$ , ON/OFF pin=ON, No Load  | 50                               | 60           | 110                    | uA     |   |
| Ground Pin Current In Power-off Mode           | $I_{SS2}$  | $V_{IN}=V_{OUT(S)}+1V$ , ON/OFF pin=OFF, No Load   |                                  | 0.3          | 1.0                    | uA     |   |
| Short Circuit Current                          | $I_{SC}$   | $V_{IN}=V_{OUT(S)}+1V$ , ON/OFF pin=ON, $V_{OUT}=0V$   |                                  | 0.5          |                        | A      |   |
| Output Voltage Temperature Coefficient(Note 6) | $\frac{\Delta V_{OUT}}{(\Delta T_A \times V_{OUT})}$     | $V_{IN}=V_{OUT(S)}+1V, I_{OUT}=100mA$ ,<br>$-40^\circ\text{C} \leq T_A \leq +85^\circ\text{C}$ |                                  | ±100         |                        | ppm/°C |   |

■ ELECTRICAL CHARACTERISTICS (Cont.)

| PARAMETER                                  | SYMBOL            | TEST CONDITIONS  | MIN                            | TYP | MAX | UNIT |
|--|-------------------|--|--------------------------------|-----|-----|------|
| ON/OFF Pin Input Voltage "H"               | V <sub>SH</sub>   | V <sub>IN</sub> =V <sub>OUT(S)</sub> +1V, R <sub>L</sub> =1.0KΩ  | 1.5                            |     |     | V    |
| ON/OFF Pin Input Voltage "L"               | V <sub>SL</sub>   | Determined by V <sub>OUT</sub> output level  |                                |     | 0.3 |      |
| ON/OFF Pin Input Current "H"               | I <sub>SH</sub>   | V <sub>IN</sub> =V <sub>OUT(S)</sub> +1V, V <sub>ON/OFF</sub> =5.5V  | -0.1                           |     | 0.1 | μA   |
| ON/OFF Pin Input Current "L"               | I <sub>SL</sub>   | V <sub>IN</sub> =V <sub>OUT(S)</sub> +1V, V <sub>ON/OFF</sub> =0V  | -0.1                           |     | 0.1 | μA   |
| Reverse Current(Note 8)                    | I <sub>REV</sub>  | V <sub>IN</sub> =0V, V <sub>OUT</sub> = 6.0V   |                                | 0.1 | 1.5 | μA   |
| V <sub>OUT</sub> Pin Sink Current (Note 9) | I <sub>REVS</sub> | V <sub>IN</sub> =5.0V, V <sub>OUT</sub> =6.0V  |                                | 0.1 | 1.5 | μA   |
| Ripple Rejection                           | RR                | V <sub>IN</sub> =V <sub>OUT(S)</sub> +1V,<br>f=1kHz,<br>ΔV <sub>rip</sub> =0.5Vrms,<br>I <sub>OUT</sub> =100mA | 1.2V≤V <sub>OUT(S)</sub> <3.0V | 65  |     | dB   |
|  |                   | 3.0V≤V <sub>OUT(S)</sub> ≤3.5V   | 60                             |     |     |      |
|  |                   | 3.5V≤V <sub>OUT(S)</sub> ≤5.0V   | 55                             |     |     |      |
| Thermal Shutdown detection temperature     | T <sub>SD</sub>   | Junction temperature   |                                | 150 |     | °C   |
| Thermal Shutdown release temperature       | T <sub>SR</sub>   | Junction temperature   |                                | 120 |     | °C   |

Notes: 1. The UTC **LR1812** output must be diode-clamped to ground. If used in a dual-supply system where the regulator load is returned to a negative supply.

2. Devices must be derated based on package thermal resistance at elevated temperatures.

3. V<sub>OUT(S)</sub>: Specified output voltage

V<sub>OUT(E)</sub>: Actual output voltage

Output voltage when fixing I<sub>OUT</sub>(=100mA) and inputting V<sub>OUT(S)</sub>+1.0V

4. V<sub>drop</sub>=V<sub>IN1</sub>-(V<sub>OUT3</sub>×0.98)

V<sub>OUT3</sub> is the output voltage when V<sub>IN</sub>=V<sub>OUT(S)</sub>+1.0V and I<sub>OUT</sub>=300mA, 1000mA.

5. The output current at which the output voltage becomes 95% of V<sub>OUT(E)</sub> after gradually increasing the output current.

6. The change in temperature [mV/°C] is calculated using the following equation.

$$\frac{\Delta V_{OUT}}{\Delta T_A} [mV/°C] = V_{OUT(S)} [V] \times \frac{\Delta V_{OUT}}{\Delta T_A \times V_{OUT}} [ppm/°C] \div 1000$$

7. The output current can be at least this value.

Due to restrictions on the package power dissipation, this value may not be satisfied. Attention should be paid to the power dissipation of the package when the output current is large.

This specification is guaranteed by design.

8. Reverse current (I<sub>REV</sub>) flows from V<sub>OUT</sub> to V<sub>IN</sub>.

9. V<sub>OUT</sub> pin sink current (I<sub>REVS</sub>) flows from V<sub>OUT</sub> to GND.

## ■ TYPICAL APPLICATION CIRCUIT

### Fixed Output Voltage

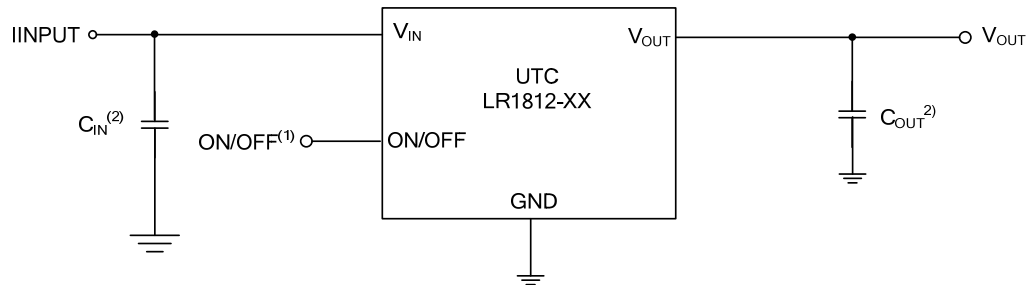

(1) ON/OFF pins must be pulled high through a 10kΩ pull-up resistor.

(2) Generally a series regulator may cause oscillation, depending on the selection of external parts. The following conditions are recommended for this IC. However, be sure to perform sufficient evaluation under the actual usage conditions for selection, including evaluation of temperature characteristics.

Input capacitor ( $C_{IN}$ ): 2.2μF or more

Output capacitor ( $C_L$ ): 2.2μF or more

UTC assumes no responsibility for equipment failures that result from using products at values that exceed, even momentarily, rated values (such as maximum ratings, operating condition ranges, or other parameters) listed in products specifications of any and all UTC products described or contained herein. UTC products are not designed for use in life support appliances, devices or systems where malfunction of these products can be reasonably expected to result in personal injury. Reproduction in whole or in part is prohibited without the prior written consent of the copyright owner. UTC reserves the right to make changes to information published in this document, including without limitation specifications and product descriptions, at any time and without notice. This document supersedes and replaces all information supplied prior to the publication hereof.