



# 7NM60-U2

**Power MOSFET**

## 7.0A, 600V N-CHANNEL SUPER-JUNCTION MOSFET

### DESCRIPTION

The UTC **7NM60-U2** is a Super Junction MOSFET Structure and is designed to have better characteristics, such as fast switching time, low gate charge, low on-state resistance and high rugged avalanche characteristics. This power MOSFET is usually used in high speed switching applications at power supplies, PWM motor controls, high efficient DC to DC converters and bridge circuits.

### FEATURES

- \*  $R_{DS(ON)} \leq 0.93 \Omega @ V_{GS}=10V, I_D=3.5A$
- \* Fast Switching Capability
- \* Improved dv/dt Capability, High Ruggedness

### SYMBOL

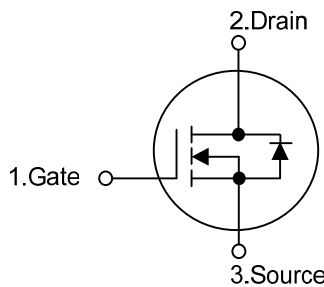

### ORDERING INFORMATION

Ordering Number		Package	Pin Assignment			Packing
Lead Free	Halogen Free		1	2	3	
7NM60L-TF1-T	7NM60G-TF1-T	TO-220F1	G	D	S	Tube
7NM60L-TM3-T	7NM60G-TM3-T	TO-251	G	D	S	Tube
7NM60L-TMS-T	7NM60G-TMS-T	TO-251S	G	D	S	Tube
7NM60L-TMS2-T	7NM60G-TMS2-T	TO-251S2	G	D	S	Tube
7NM60L-TN3-R	7NM60G-TN3-R	TO-252	G	D	S	Tape Reel

Note: Pin Assignment: G: Gate D: Drain S: Source

<p>7NM60G-TF1-T</p> <p>(1)Packing Type</p> <p>(2)Package Type</p> <p>(3)Green Package</p>	<p>(1) T: Tube, R: Tape Reel</p> <p>(2) TF1: TO-220F1, TM3: TO-251, TMS: TO-251S, TMS2: TO-251S2, TN3: TO-252</p> <p>(3) G: Halogen Free and Lead Free, L: Lead Free,</p>
---	---

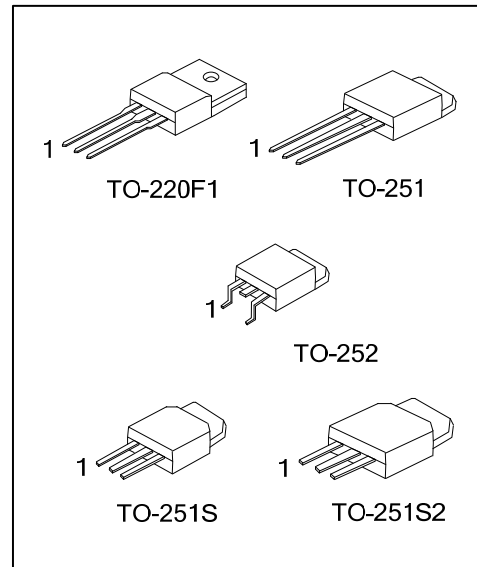

MARKING

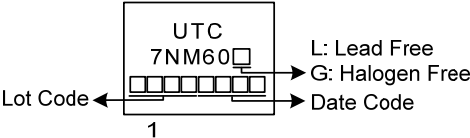

■ ABSOLUTE MAXIMUM RATINGS ( $T_C = 25^\circ\text{C}$ , unless otherwise specified)

PARAMETER		SYMBOL	RATINGS	UNIT	
Drain-Source Voltage		$V_{DSS}$	600	V	
Gate-Source Voltage		$V_{GSS}$	$\pm 30$	V	
Drain Current	Continuous	$I_D$	$T_C=25^\circ\text{C}$	7	A
			$T_C=100^\circ\text{C}$	4.5	
	Pulsed (Note 2)		$I_{DM}$	21	A
Avalanche Energy	Single Pulsed (Note 3)		$E_{AS}$	144	mJ
Peak Diode Recovery dv/dt (Note 4)		dv/dt	4	V/ns	
Power Dissipation	TO-220F1		$P_D$	25	W
	TO-251/TO-251S			50	W
	TO-251S2/TO-252				
Junction Temperature		$T_J$	+150	$^\circ\text{C}$	
Storage Temperature		$T_{STG}$	-55 ~ +150	$^\circ\text{C}$	

Notes: 1. Absolute maximum ratings are those values beyond which the device could be permanently damaged.

Absolute maximum ratings are stress ratings only and functional device operation is not implied.

2. Repetitive Rating: Pulse width limited by maximum junction temperature.

3.  $L=100\text{mH}$ ,  $I_{AS}=1.7\text{A}$ ,  $V_{DD}=50\text{V}$ ,  $R_G=25\ \Omega$ , Starting  $T_J = 25^\circ\text{C}$ .

4.  $I_{SD} \leq 7.0\text{A}$ ,  $di/dt \leq 200\text{A}/\mu\text{s}$ ,  $V_{DD} \leq BV_{DSS}$ , Starting  $T_J = 25^\circ\text{C}$ .

■ THERMAL DATA

PARAMETER		SYMBOL	RATINGS	UNIT
Junction to Ambient	TO-220F1	$\theta_{JA}$	62.5	$^\circ\text{C}/\text{W}$
	TO-251/TO-251S		110	$^\circ\text{C}/\text{W}$
	TO-251S2/TO-252			
Junction to Case	TO-220F1	$\theta_{JC}$	5.0	$^\circ\text{C}/\text{W}$
	TO-251/TO-251S		2.5(Note)	$^\circ\text{C}/\text{W}$
	TO-251S2/TO-252			

Note: The data tested by surface mounted on a 1 inch<sup>2</sup> FR-4 board with 2OZ copper.

ELECTRICAL CHARACTERISTICS ( $T_J = 25^\circ\text{C}$  unless otherwise specified)

PARAMETER	SYMBOL	TEST CONDITIONS	MIN	TYP	MAX	UNIT
<b>OFF CHARACTERISTICS</b>						
Drain-Source Breakdown Voltage	$BV_{DSS}$	$V_{GS}=0V, I_D=250\mu A$	600			V
Drain-Source Leakage Current	$I_{DSS}$	$V_{DS}=600V, V_{GS}=0V$			10	$\mu A$
Gate-Source Leakage Current	Forward	$V_{GS}=30V, V_{DS}=0V$ $V_{GS}=-30V, V_{DS}=0V$			100	nA
	Reverse				-100	
<b>ON CHARACTERISTICS</b>						
Gate Threshold Voltage	$V_{GS(TH)}$	$V_{DS}=V_{GS}, I_D=250\mu A$	2.5		4.5	V
Static Drain-Source On-State Resistance	$R_{DS(ON)}$	$V_{GS}=10V, I_D=3.5A$			0.93	$\Omega$
<b>DYNAMIC CHARACTERISTICS</b>						
Input Capacitance	$C_{ISS}$	$V_{GS}=0V, V_{DS}=50V, f=1.0MHz$		336		pF
Output Capacitance	$C_{OSS}$			68		pF
Reverse Transfer Capacitance	$C_{RSS}$			6		pF
<b>SWITCHING CHARACTERISTICS</b>						
Total Gate Charge (Note 1)	$Q_G$	$V_{DS}=480V, V_{GS}=10V, I_D=7.0A$ (Note 1, 2)		23.5		nC
Gate to Source Charge	$Q_{GS}$			9		nC
Gate to Drain Charge	$Q_{GD}$			7.5		nC
Turn-ON Delay Time (Note 1)	$t_{D(ON)}$	$V_{DD}=100V, V_{GS}=10V,$ $I_D=7.0A, R_G=25\Omega$ (Note 1, 2)		6		ns
Rise Time	$t_R$			19		ns
Turn-OFF Delay Time	$t_{D(OFF)}$			36		ns
Fall-Time	$t_F$			26		ns
<b>SOURCE- DRAIN DIODE RATINGS AND CHARACTERISTICS</b>						
Maximum Body-Diode Continuous Current	$I_S$				7.0	A
Maximum Body-Diode Pulsed Current	$I_{SM}$				21	A
Drain-Source Diode Forward Voltage (Note 1)	$V_{SD}$	$I_S=7.0A, V_{GS}=0V$			1.4	V
Body Diode Reverse Recovery Time (Note 1)	$t_{rr}$	$I_S=7.0A, V_{GS}=0V,$ $dI_F/dt=100A/\mu s$		265		ns
Body Diode Reverse Recovery Charge	$Q_{rr}$			2.9		$\mu C$

Notes: 1. Pulse Test: Pulse width  $\leq 300\mu s$ , Duty cycle  $\leq 2\%$ .

2. Essentially independent of operating temperature.

■ TEST CIRCUITS AND WAVEFORMS

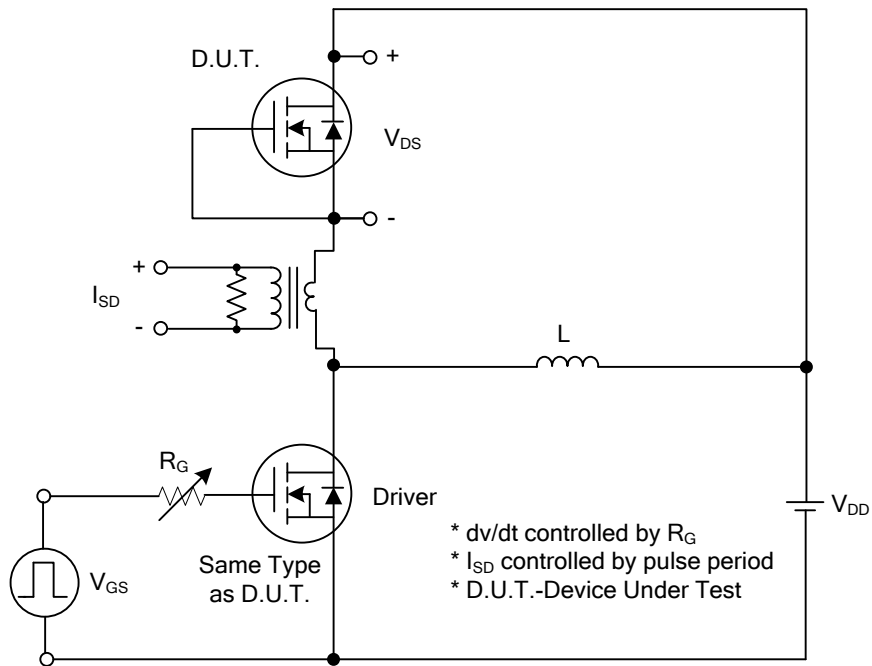

Peak Diode Recovery dv/dt Test Circuit

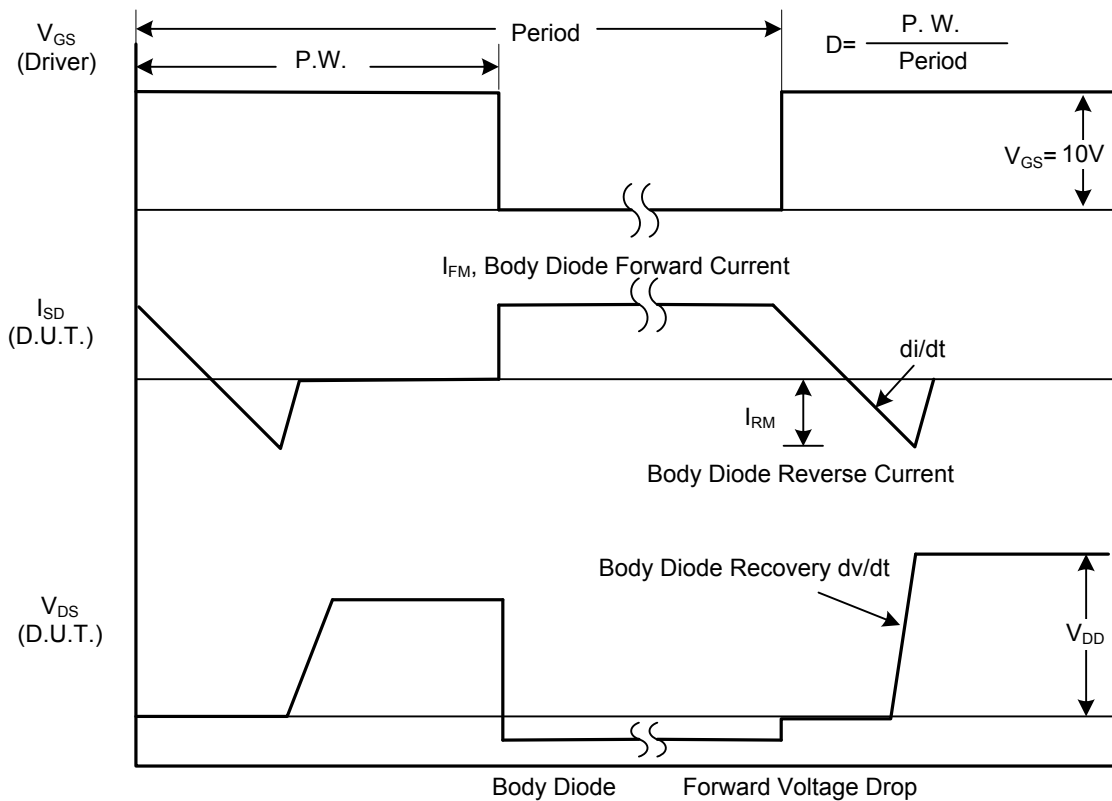

Peak Diode Recovery dv/dt Waveforms

## TEST CIRCUITS AND WAVEFORMS

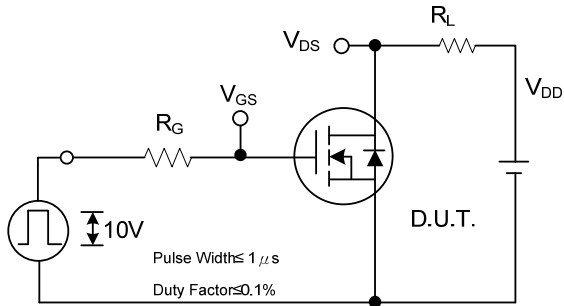

**Switching Test Circuit**

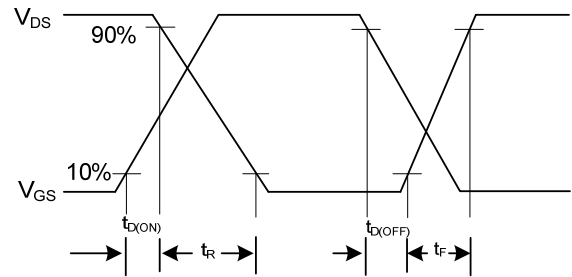

**Switching Waveforms**

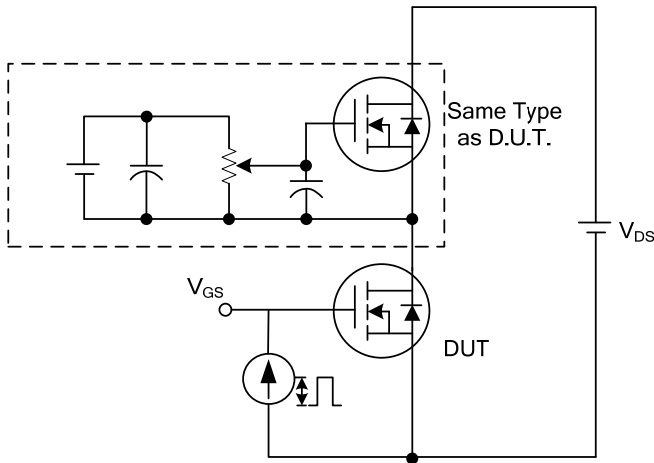

**Gate Charge Test Circuit**

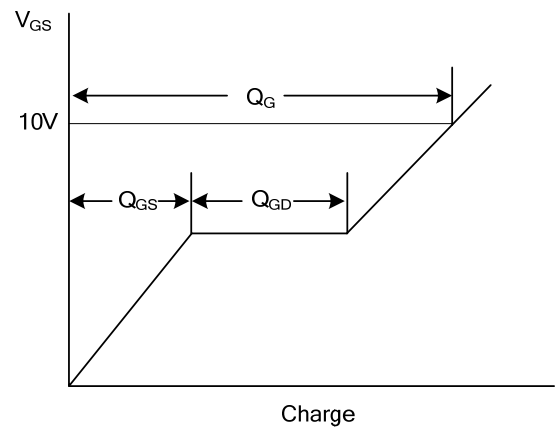

**Gate Charge Waveform**

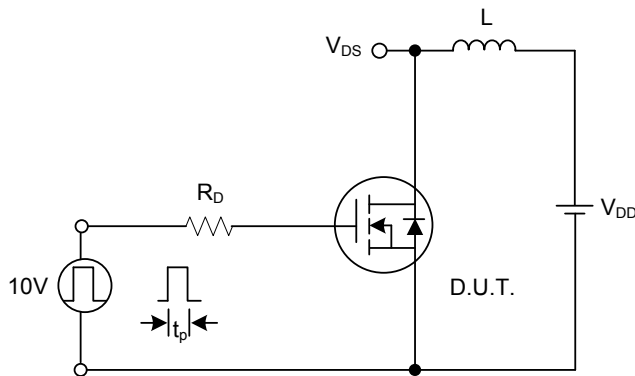

**Unclamped Inductive Switching Test Circuit**

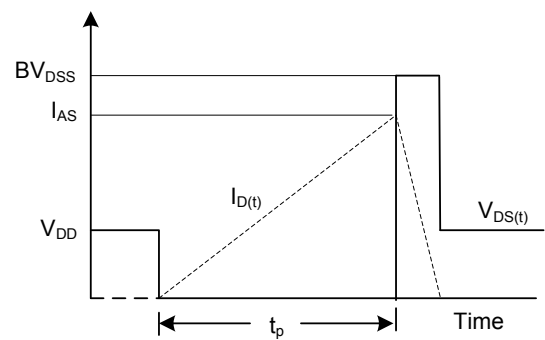

**Unclamped Inductive Switching Waveforms**

## TYPICAL CHARACTERISTICS

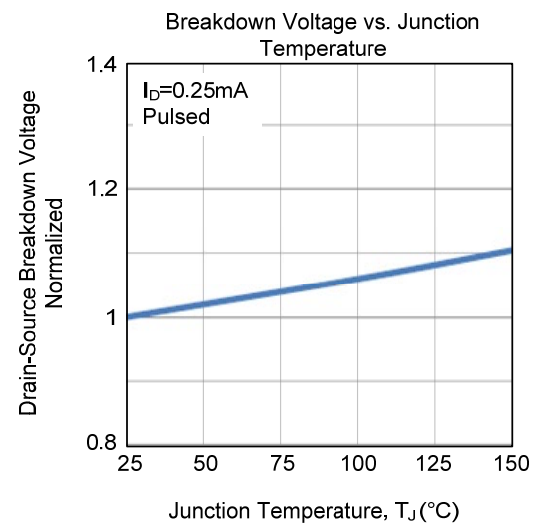
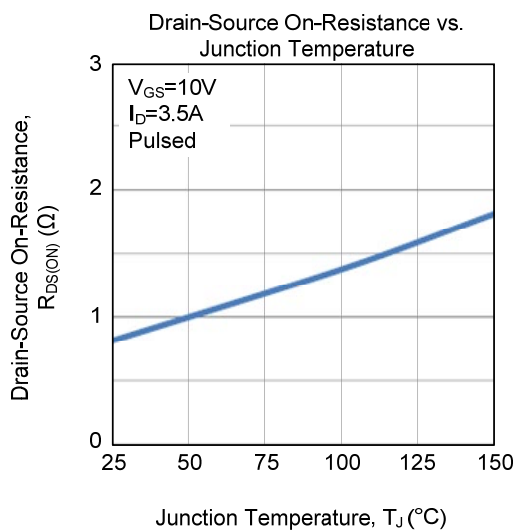
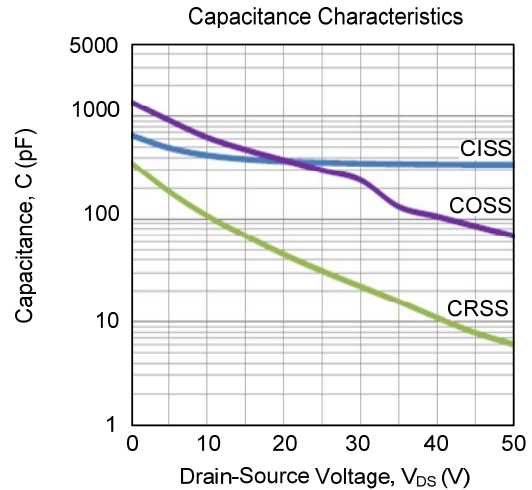
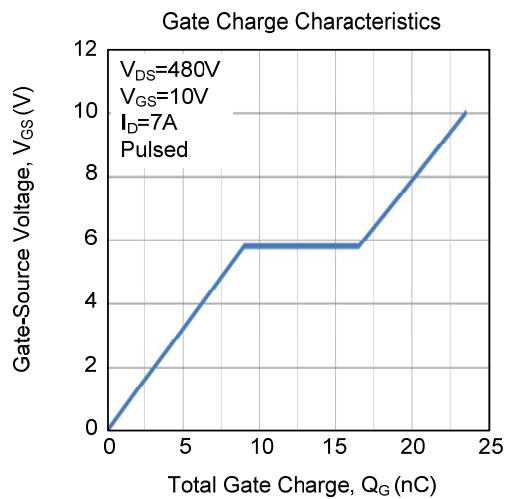
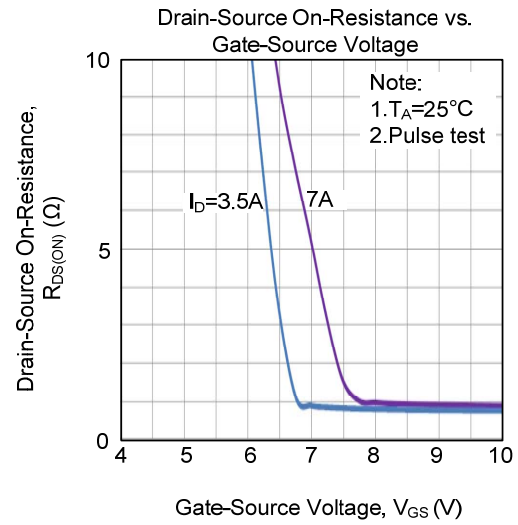
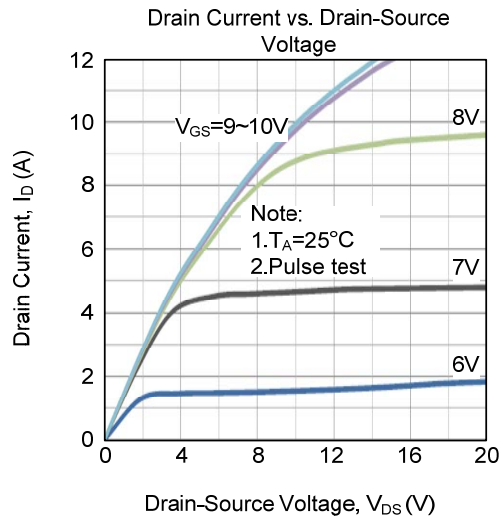

## ■ TYPICAL CHARACTERISTICS (Cont.)

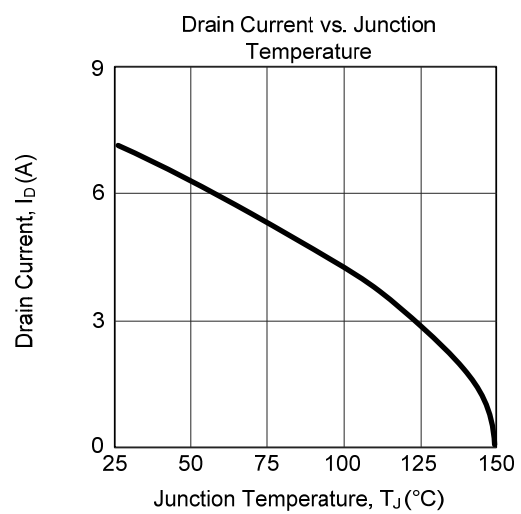
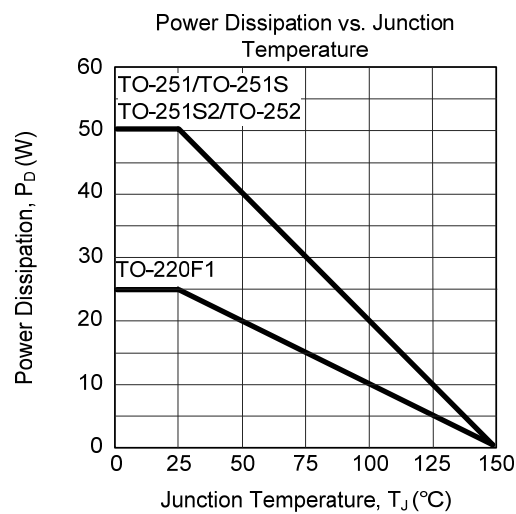
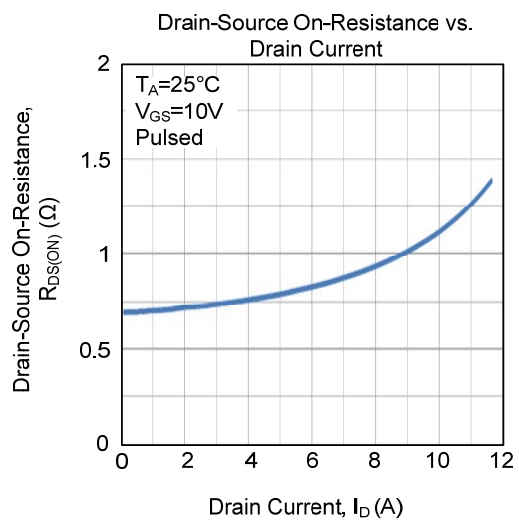
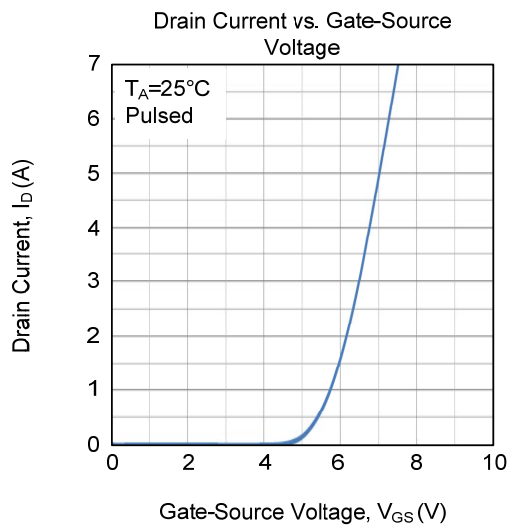
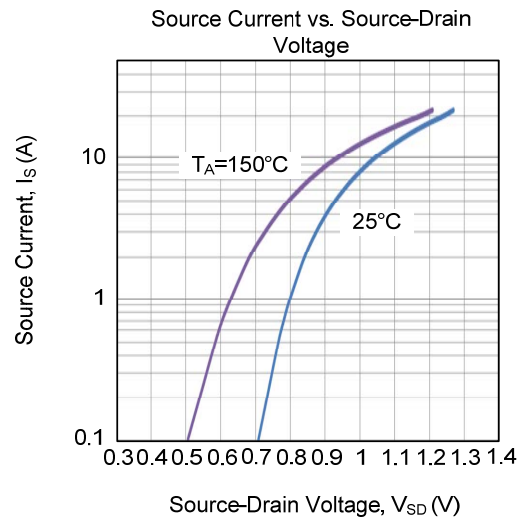
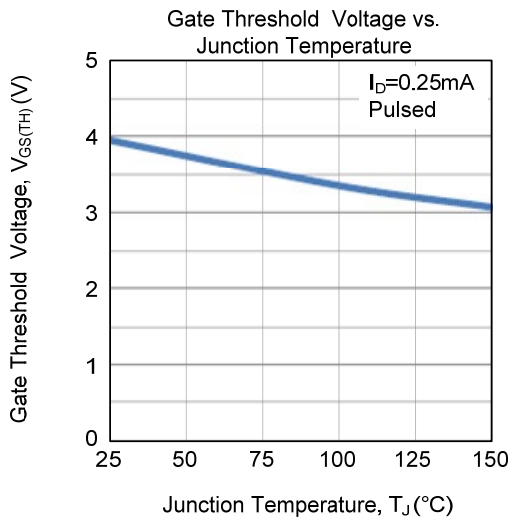



■ TYPICAL CHARACTERISTICS (Cont.)

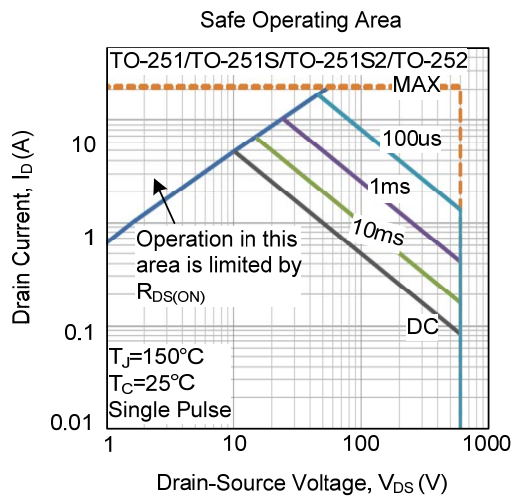

UTC assumes no responsibility for equipment failures that result from using products at values that exceed, even momentarily, rated values (such as maximum ratings, operating condition ranges, or other parameters) listed in products specifications of any and all UTC products described or contained herein. UTC products are not designed for use in life support appliances, devices or systems where malfunction of these products can be reasonably expected to result in personal injury. Reproduction in whole or in part is prohibited without the prior written consent of the copyright owner. UTC reserves the right to make changes to information published in this document, including without limitation specifications and product descriptions, at any time and without notice. This document supersedes and replaces all information supplied prior to the publication hereof.