



8NM60-U2

Power MOSFET

8A, 600V N-CHANNEL SUPER-JUNCTION MOSFET

DESCRIPTION

The **UTC 8NM60-U2** is a Super Junction MOSFET Structure and is designed to have better characteristics, such as fast switching time, low gate charge, low on-state resistance and a high rugged avalanche characteristics. This power MOSFET is usually used at DC-DC, AC-DC converters for power applications.

FEATURES

- * $R_{DS(ON)} < 0.8\Omega @ V_{GS}=10V, I_D=4.0A$
- * By using Super Junction Structure
- * Fast Switching
- * With 100% Avalanche Tested

SYMBOL

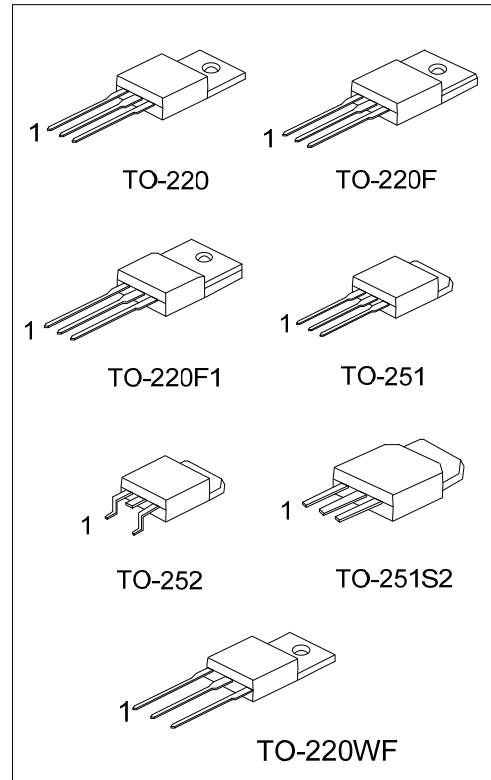
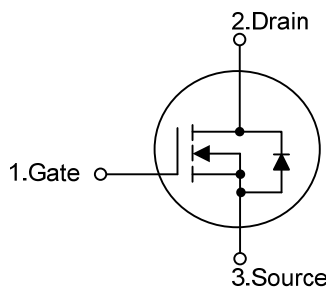

ORDERING INFORMATION

Ordering Number		Package	Pin Assignment			Packing
Lead Free	Halogen Free		1	2	3	
8NM60L-TA3-T	8NM60G-TA3-T	TO-220	G	D	S	Tube
8NM60L-TF3-T	8NM60G-TF3-T	TO-220F	G	D	S	Tube
8NM60L-TF1-T	8NM60G-TF1-T	TO-220F1	G	D	S	Tube
8NM60L-TW1-T	8NM60G-TW1-T	TO-220WF	G	D	S	Tube
8NM60L-TM3-T	8NM60G-TM3-T	TO-251	G	D	S	Tube
8NM60L-TMS2-T	8NM60G-TMS2-T	TO-251S2	G	D	S	Tube
8NM60L-TN3-R	8NM60G-TN3-R	TO-252	G	D	S	Tape Reel

Note: Pin Assignment: G: Gate D: Drain S: Source

<p>8NM60G-TA3-T</p> <p>(1)Packing Type (2)Package Type (3)Green Package</p>	<p>(1) T: Tube, R: Tape Reel (2) TA3: TO-220, TF1: TO-220F1, TF3: TO-220F TW1: TO-220WF, TM3: TO-251, TMS2: TO-251S2, TN3: TO-252 (3) G: Halogen Free and Lead Free, L: Lead Free</p>
---	---

■ MARKING

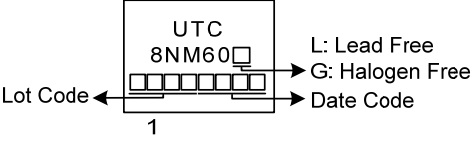

■ ABSOLUTE MAXIMUM RATINGS ($T_c=25^{\circ}\text{C}$, unless otherwise specified)

PARAMETER		SYMBOL	RATINGS	UNIT
Drain-Source Voltage		V_{DSS}	600	V
Gate-Source Voltage		V_{GSS}	± 30	V
Continuous Drain Current	Continuous	I_D	8.0	A
Pulsed Drain Current	Pulsed (Note 2)	I_{DM}	32	A
Avalanche Current (Note 3)		I_{AR}	3.1	A
Avalanche energy	Single Pulsed (Note 3)	E_{AS}	200	mJ
Peak Diode Recovery dv/dt (Note 4)		dv/dt	4.5	V/nS
Power Dissipation	TO-220	P_D	60	W
	TO-220F/TO-220F1		26	W
	TO-220WF			
	TO-251S2		55	W
	TO-252			
Junction Temperature		T_J	+150	$^{\circ}\text{C}$
Storage Temperature Range		T_{STG}	-55 ~ +150	$^{\circ}\text{C}$

Notes: 1. Absolute maximum ratings are those values beyond which the device could be permanently damaged.

Absolute maximum ratings are stress ratings only and functional device operation is not implied.

2. Repetitive Rating: Pulse width limited by maximum junction temperature.

3. $L=41.6\text{mH}$, $I_{AS}=3.1\text{A}$, $V_{DD}=50\text{V}$, $R_G=25\Omega$, Starting $T_J = 25^{\circ}\text{C}$.

4. $I_{SD} \leq 8.0\text{A}$, $di/dt \leq 200\text{A}/\mu\text{s}$, $V_{DD} \leq V_{(BR)DSS}$, $T_J = 25^{\circ}\text{C}$.

■ THERMAL DATA

PARAMETER		SYMBOL	RATINGS	UNIT
Junction to Ambient	TO-220/TO-220F	θ_{JA}	62.5	$^{\circ}\text{C}/\text{W}$
	TO-220F1/TO-220WF			
	TO-251/TO-251S2		110	
	TO-252			
Junction to Case	TO-220	θ_{JC}	2.1	$^{\circ}\text{C}/\text{W}$
	TO-220F/TO-220F1		4.8	
	TO-220WF			
	TO-251/TO-251S2		2.27	
TO-252 (Note)				

Note: The data tested by surface mounted on a 1 inch² FR-4 board with 2OZ copper.

■ ELECTRICAL CHARACTERISTICS (T_J =25°C, unless otherwise specified)

PARAMETER	SYMBOL	TEST CONDITIONS	MIN	TYP	MAX	UNIT
OFF CHARACTERISTICS						
Drain-Source Breakdown Voltage	BV _{DSS}	V _{GS} =0V, I _D =250μA	600			V
Drain-Source Leakage Current	I _{DSS}	V _{DS} =600V, V _{GS} =0V			10	μA
Gate-Source Leakage Current	Forward	I _{GSS} V _{DS} =0V, V _{GS} =+30V			+100	nA
	Reverse		V _{DS} =0V, V _{GS} =-30V			-100
ON CHARACTERISTICS						
Gate Threshold Voltage	V _{GS(TH)}	V _{DS} = V _{GS} , I _D =250μA	2.5		4.5	V
Drain-Source On-State Resistance	R _{DS(ON)}	V _{GS} =10V, I _D =4.0A			0.8	Ω
DYNAMIC PARAMETERS						
Input Capacitance	C _{ISS}	V _{GS} =0V, V _{DS} =25V, f=1.0MHz		420		pF
Output Capacitance	C _{OSS}			318		pF
Reverse Transfer Capacitance	C _{RSS}			33		pF
SWITCHING PARAMETERS						
Total Gate Charge (Note 1)	Q _G	V _{DS} =100V, V _{GS} =10V, I _D =8A, I _G =1mA (Note 1, 2)		16		nC
Gate to Source Charge	Q _{GS}			6		nC
Gate to Drain Charge	Q _{GD}			6		nC
Turn-on Delay Time (Note 1)	t _{D(ON)}	V _{DD} =100V, V _{GS} =10V, I _D =8A, R _G =25Ω (Note 1, 2)		8		ns
Rise Time	t _R			22		ns
Turn-off Delay Time	t _{D(OFF)}			45		ns
Fall-Time	t _F			30		ns
SOURCE- DRAIN DIODE RATINGS AND CHARACTERISTICS						
Maximum Body-Diode Pulsed Current	I _S				8.0	A
Drain-Source Diode Forward Voltage (Note 1)	I _{SM}				32	A
Maximum Body-Diode Continuous Current	V _{SD}	I _S =8.0A, V _{GS} =0V			1.4	V
Reverse Recovery Time (Note 1)	t _{rr}	I _S =8.0A, V _{GS} =0V, di _F /dt=100A/μs		290		ns
Reverse Recovery Charge	Q _{rr}				3.0	

Note: 1. Pulse Test : Pulse width ≤ 300μs, Duty cycle ≤ 2%

2. Essentially independent of operating temperature

■ TEST CIRCUITS AND WAVEFORMS

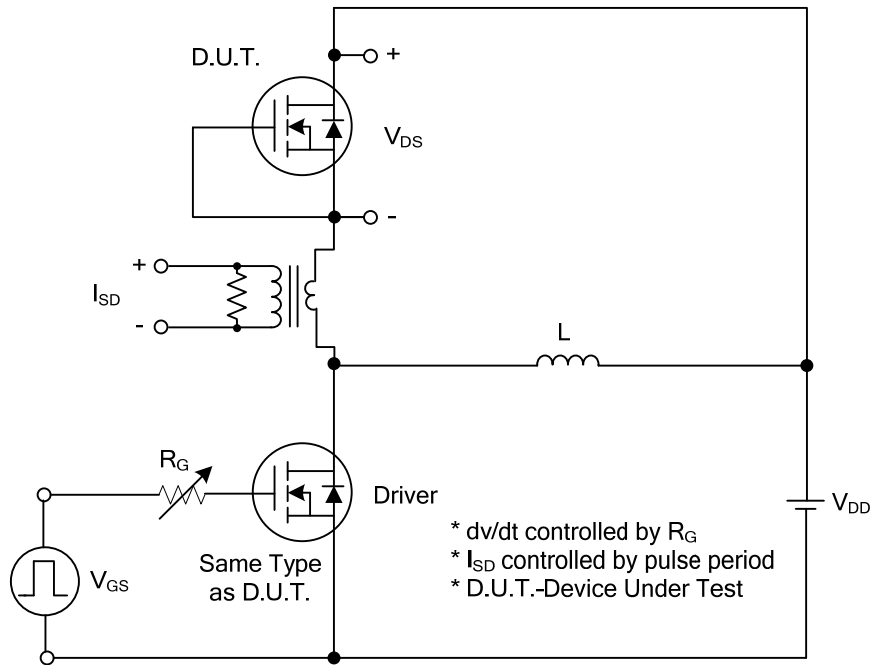

Peak Diode Recovery dv/dt Test Circuit

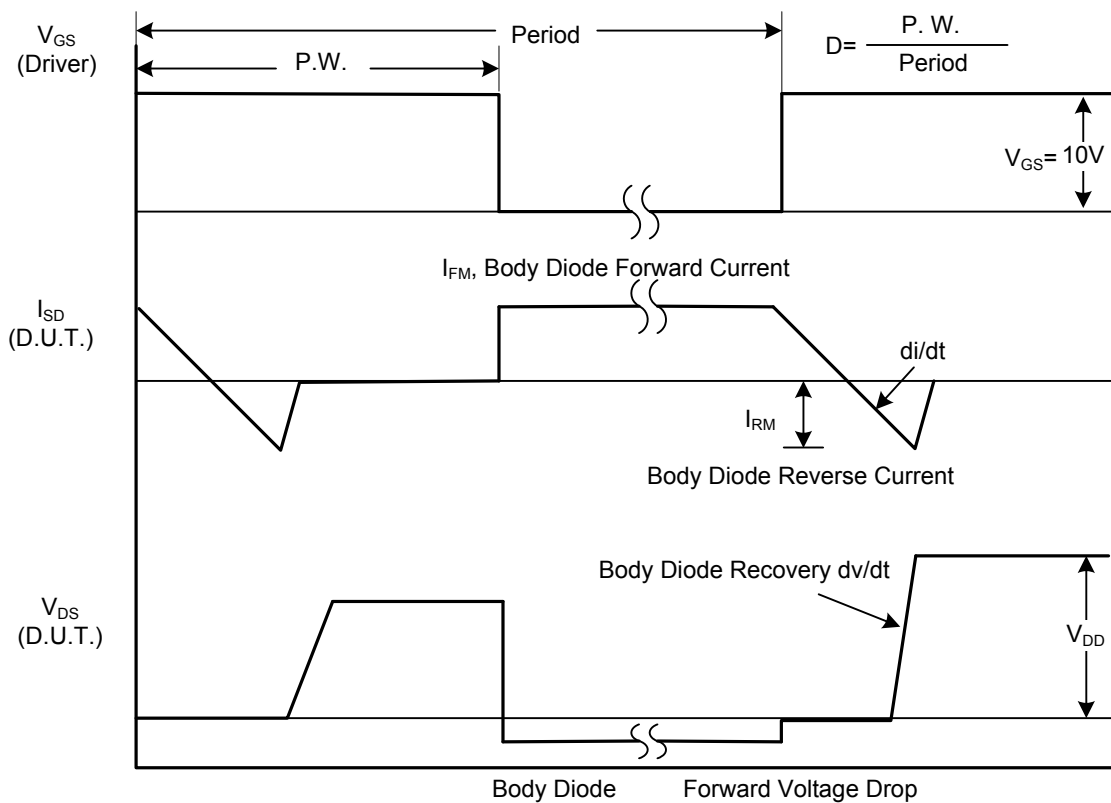

Peak Diode Recovery dv/dt Waveforms

TEST CIRCUITS AND WAVEFORMS (Cont.)

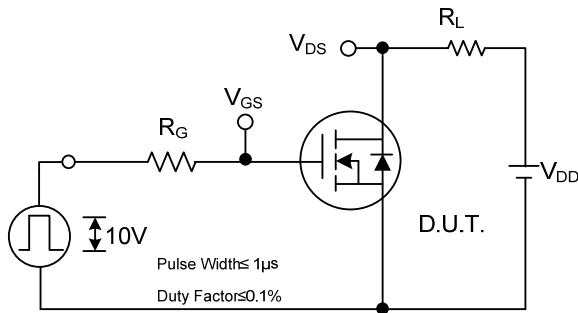

Switching Test Circuit

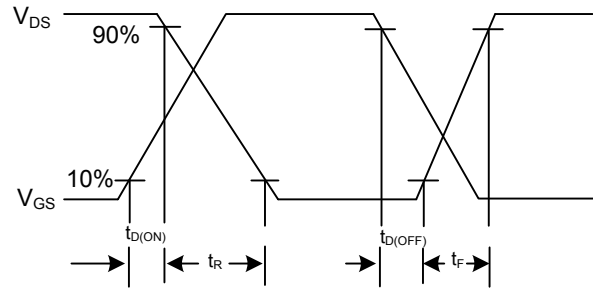

Switching Waveforms

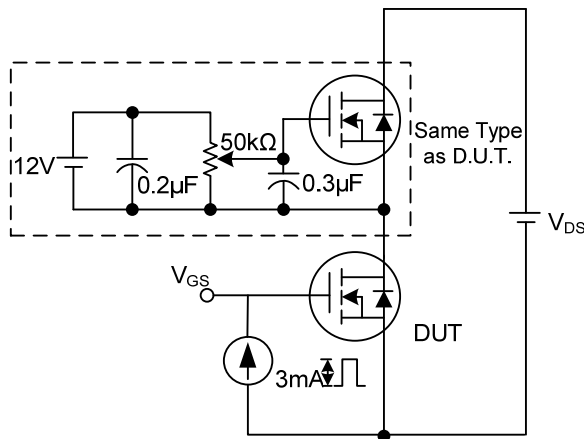

Gate Charge Test Circuit

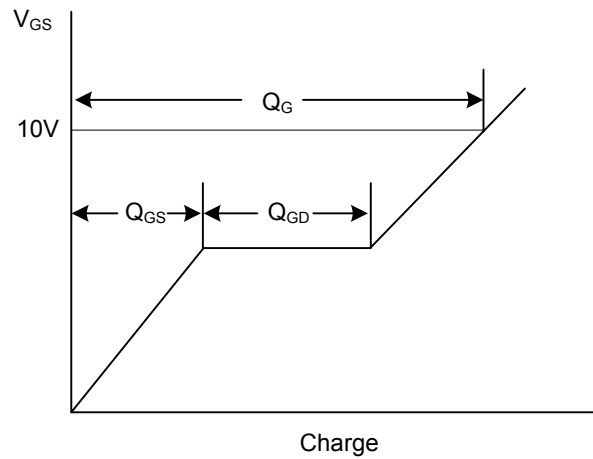

Gate Charge Waveform



Unclamped Inductive Switching Test Circuit



Unclamped Inductive Switching Waveforms

UTC assumes no responsibility for equipment failures that result from using products at values that exceed, even momentarily, rated values (such as maximum ratings, operating condition ranges, or other parameters) listed in products specifications of any and all UTC products described or contained herein. UTC products are not designed for use in life support appliances, devices or systems where malfunction of these products can be reasonably expected to result in personal injury. Reproduction in whole or in part is prohibited without the prior written consent of the copyright owner. UTC reserves the right to make changes to information published in this document, including without limitation specifications and product descriptions, at any time and without notice. This document supersedes and replaces all information supplied prior to the publication hereof.