



08NM65

Preliminary

Power MOSFET

**0.8A, 650V N-CHANNEL
SUPER-JUNCTION MOSFET**

■ DESCRIPTION

The UTC **08NM65** is an Super Junction MOSFET Structure and is designed to have better characteristics, such as fast switching time, low gate charge, low on-state resistance and have a high rugged avalanche characteristics. This power MOSFET is usually used at high speed switching applications in power supplies, PWM motor controls, high efficient DC to DC converters and bridge circuits.

■ FEATURES

- * $R_{DS(on)} < 6.15 \Omega @ V_{GS}=10V, I_D=0.4A$
- * High breakdown voltage

■ ORDERING INFORMATION

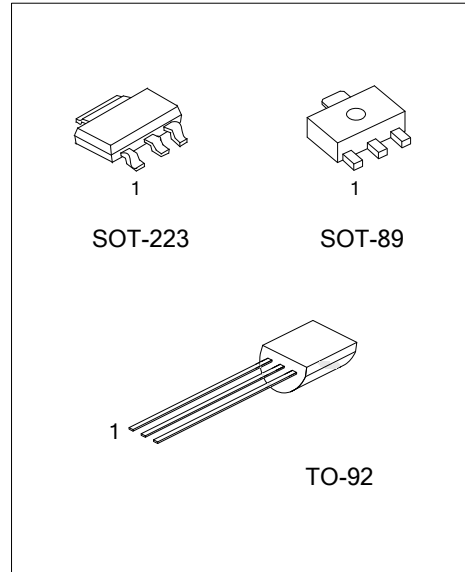

Order Number		Package	Pin Assignment			Packing
Lead Free	Halogen Free		1	2	3	
-	08NM65G-AA3-R	SOT-223	G	D	S	Tape Reel
-	08NM65G-AB3-R	SOT-89	G	D	S	Tape Reel
08NM65L-T92-B	08NM65G-T92-B	TO-92	G	D	S	Tape Box
08NM65L-T92-K	08NM65G-T92-K	TO-92	G	D	S	Bulk

Note: Pin Assignment: G: Gate D: Drain S: Source

<p>08NM65G-AA3-R</p> <p>(1)Packing Type (2)Package Type (3)Green Package</p>	<p>(1) R: Tape Reel, B: Tape Box, K: Bulk (2) AA3: SOT-223, AB3: SOT-89, T92: TO-92 (3) L: Lead Free, G: Halogen Free and Lead Free</p>
--	---

MARKING

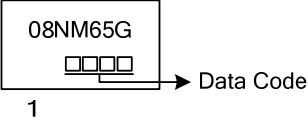
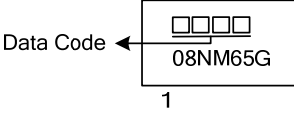
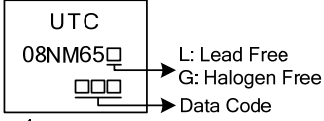
PACKAGE	MARKING
SOT-223	
SOT-89	
TO-92	

■ ABSOLUTE MAXIMUM RATINGS ($T_A = 25^\circ\text{C}$, unless otherwise specified)

PARAMETER		SYMBOL	RATINGS	UNIT
Drain-Source Voltage		V_{DSS}	650	V
Gate-Source Voltage		V_{GSS}	± 30	V
Drain Current	Continuous	I_D	0.8	A
	Pulsed	I_{DM}	3.2	A
Power Dissipation	SOT-223	P_D	9	W
	SOT-89		3.3	W
	SOT-92		1.4	W
Junction Temperature		T_J	150	$^\circ\text{C}$
Storage Temperature Range		T_{STG}	-55 ~ +150	$^\circ\text{C}$

Notes: 1. Absolute maximum ratings are those values beyond which the device could be permanently damaged. Absolute maximum ratings are stress ratings only and functional device operation is not implied.
2. Repetitive Rating : Pulse width limited by maximum junction temperature.

■ THERMAL DATA

PARAMETER		SYMBOL	RATINGS	UNIT
Junction to Ambient	SOT-223	θ_{JA}	150	$^\circ\text{C/W}$
	SOT-89		180	$^\circ\text{C/W}$
	SOT-92			
Junction to Case	SOT-223	θ_{JC}	14	$^\circ\text{C/W}$
	SOT-89		38	$^\circ\text{C/W}$
	SOT-92		88	$^\circ\text{C/W}$

■ ELECTRICAL CHARACTERISTICS ($T_C = 25^\circ\text{C}$, unless otherwise specified)

PARAMETER	SYMBOL	TEST CONDITIONS	MIN	TYP	MAX	UNIT
OFF CHARACTERISTICS						
Drain-Source Breakdown Voltage	BV_{DSS}	$I_D = 250\mu\text{A}$, $V_{GS} = 0\text{V}$	650			V
Drain-Source Leakage Current	I_{DSS}	$V_{DS} = 650\text{V}$, $V_{GS} = 0\text{V}$			10	μA
Gate-Source Leakage Current	Forward	I_{GSS}			+100	nA
	Reverse				-100	nA
ON CHARACTERISTICS						
Gate Threshold Voltage	$V_{GS(TH)}$	$V_{DS} = V_{GS}$, $I_D = 250\mu\text{A}$	2.5		4.5	V
Static Drain-Source On-State Resistance	$R_{DS(ON)}$	$V_{GS} = 10\text{V}$, $I_D = 0.4\text{A}$			6.15	Ω
DYNAMIC PARAMETERS						
Input Capacitance	C_{ISS}	$V_{GS} = 0\text{V}$, $V_{DS} = 25\text{V}$, $f = 1.0\text{MHz}$		67		pF
Output Capacitance	C_{OSS}			41		pF
Reverse Transfer Capacitance	C_{RSS}			6		pF
SWITCHING PARAMETERS						
Total Gate Charge	Q_G	$V_{DS} = 50\text{V}$, $V_{GS} = 10\text{V}$, $I_D = 1.3\text{A}$, $I_D = 100\mu\text{A}$ (Note 1, 2)		12		nC
Gate to Source Charge	Q_{GS}			2		nC
Gate to Drain Charge	Q_{GD}			4		nC
Turn-ON Delay Time	$t_{D(ON)}$	$V_{DS} = 30\text{V}$, $V_{GS} = 10\text{V}$, $I_D = 0.5\text{A}$, $R_G = 25\Omega$ (Note 1, 2)		28		ns
Rise Time	t_R			26		ns
Turn-OFF Delay Time	$t_{D(OFF)}$			42		ns
Fall-Time	t_F			33		ns
SOURCE- DRAIN DIODE RATINGS AND CHARACTERISTICS						
Maximum Body-Diode Continuous Current	I_S				0.8	A
Maximum Body-Diode Pulsed Current	I_{SM}				3.2	A
Drain-Source Diode Forward Voltage	V_{SD}	$I_S = 0.8\text{A}$, $V_{GS} = 0\text{V}$			1.4	V

Notes: 1. Pulse Test: Pulse width $\leq 300\mu\text{s}$, Duty cycle $\leq 2\%$.
2. Essentially independent of operating temperature.

■ TEST CIRCUITS AND WAVEFORMS

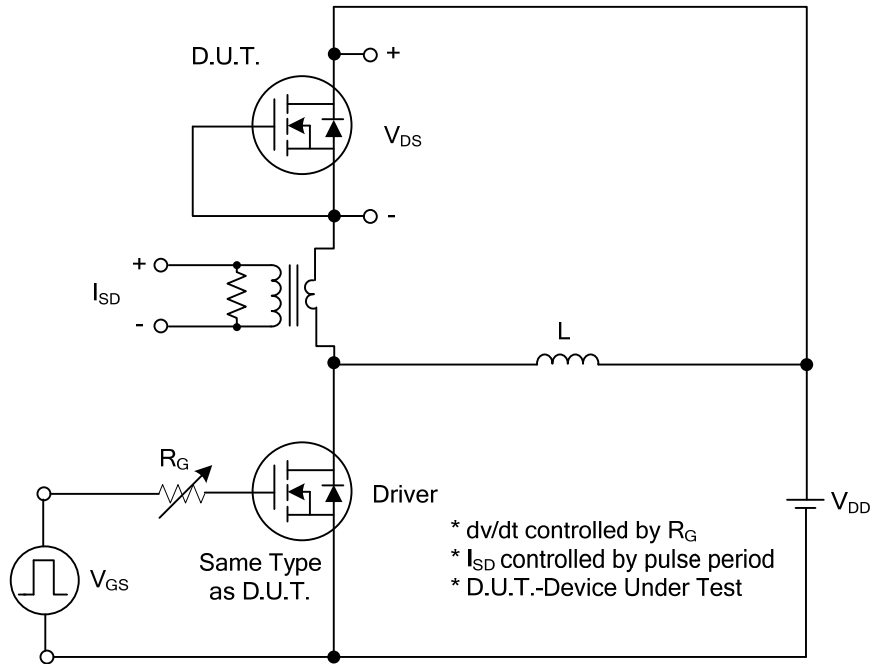

Peak Diode Recovery dv/dt Test Circuit

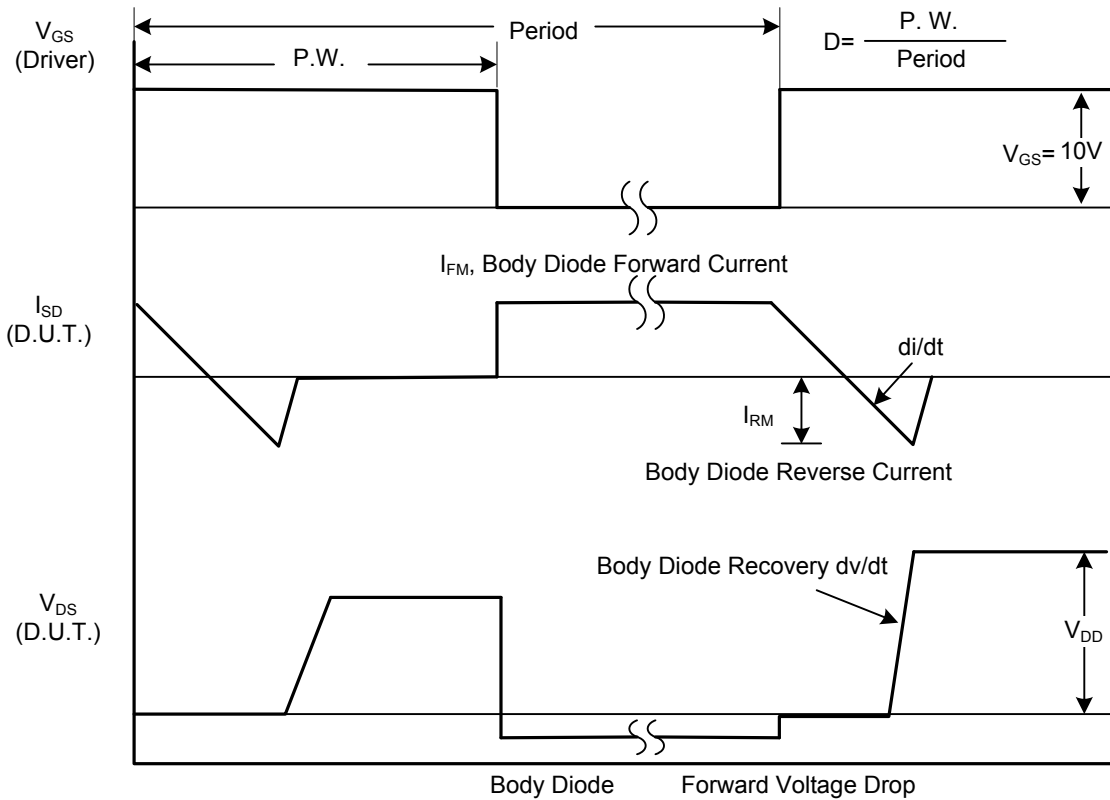

Peak Diode Recovery dv/dt Waveforms

■ TEST CIRCUITS AND WAVEFORMS (Cont.)

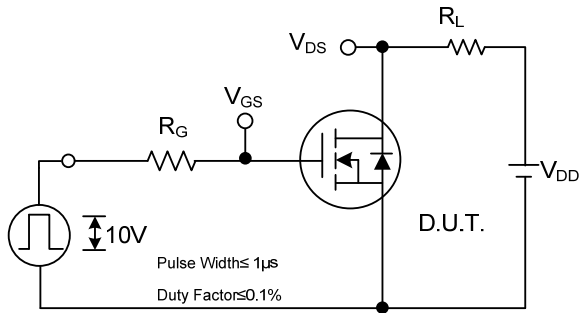

Switching Test Circuit

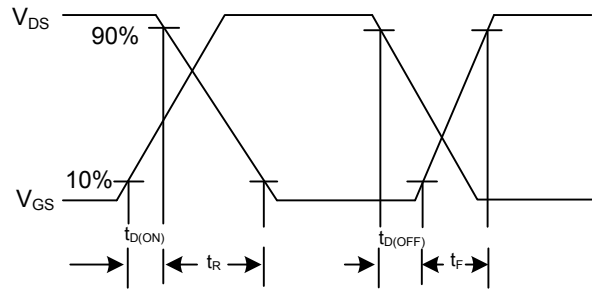

Switching Waveforms

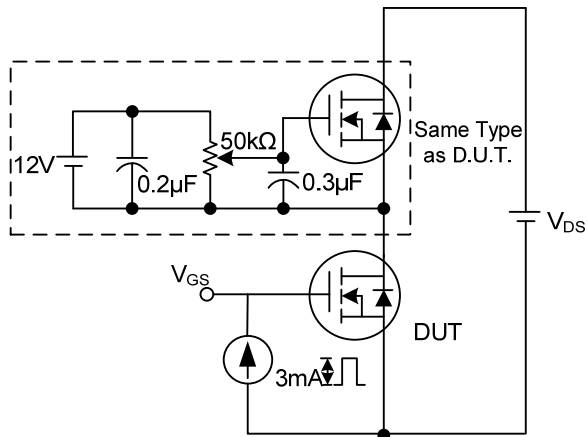

Gate Charge Test Circuit

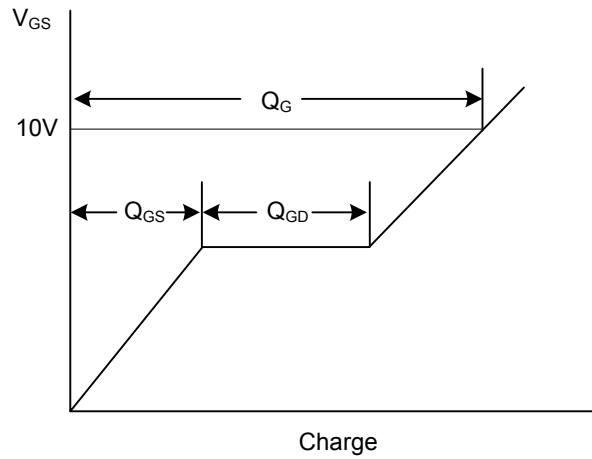

Gate Charge Waveform

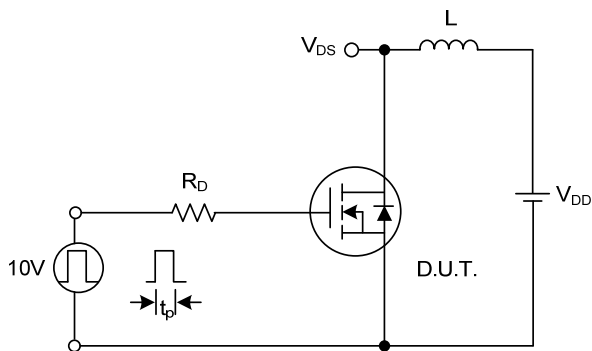

Unclamped Inductive Switching Test Circuit

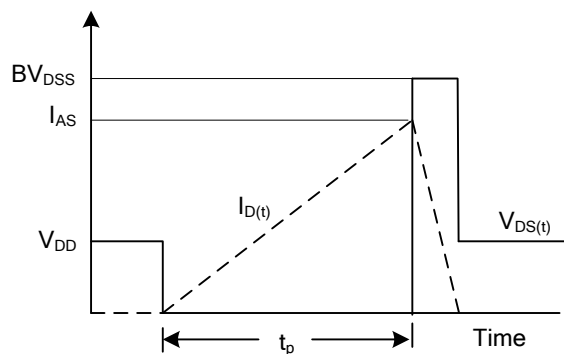

Unclamped Inductive Switching Waveforms

UTC assumes no responsibility for equipment failures that result from using products at values that exceed, even momentarily, rated values (such as maximum ratings, operating condition ranges, or other parameters) listed in products specifications of any and all UTC products described or contained herein. UTC products are not designed for use in life support appliances, devices or systems where malfunction of these products can be reasonably expected to result in personal injury. Reproduction in whole or in part is prohibited without the prior written consent of the copyright owner. The information presented in this document does not form part of any quotation or contract, is believed to be accurate and reliable and may be changed without notice.