



## 05NM65

Preliminary

Power MOSFET

### 0.5A, 650V N-CHANNEL SUPER-JUNCTION MOSFET

#### DESCRIPTION

The UTC **05NM65** is an Super Junction MOSFET Structure and is designed to have better characteristics, such as fast switching time, low gate charge, low on-state resistance and have a high rugged avalanche characteristics. This power MOSFET is usually used at high speed switching applications in power supplies, PWM motor controls, high efficient DC to DC converters and bridge circuits.

#### FEATURES

- \*  $R_{DS(on)} < 13 \Omega @ V_{GS}=10V, I_D=0.25A$
- \* High breakdown voltage

#### ORDERING INFORMATION

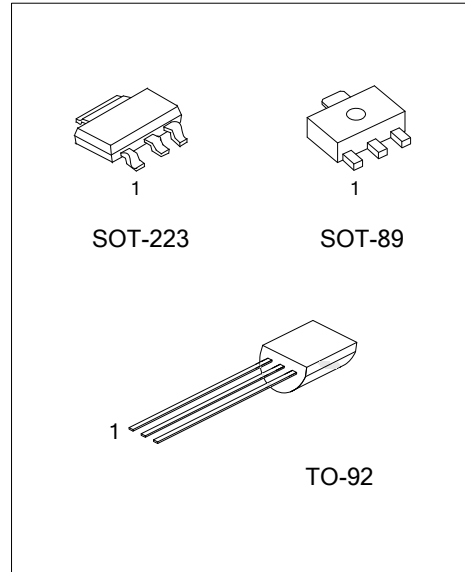

Ordering Number		Package	Pin Assignment			Packing
Lead Free	Halogen Free		1	2	3	
-	05NM65G-AA3-R	SOT-223	G	D	S	Tape Reel
-	05NM65G-AB3-R	SOT-89	G	D	S	Tape Reel
05NM65L-T92-B	05NM65G-T92-B	TO-92	G	D	S	Tape Box
05NM65L-T92-K	05NM65G-T92-K	TO-92	G	D	S	Bulk

Note: Pin Assignment: G: Gate D: Drain S: Source

<p>05NM65G-AA3-R</p> <p>(1)Packing Type (2)Package Type (3)Green Package</p>	<p>(1) R: Tape Reel, T: Tube, B: Tape Box, K: Bulk (2) AA3: SOT-223, AB3: SOT-89, T92: TO-92 (3) L: Lead Free, G: Halogen Free and Lead Free</p>
--	--

### MARKING

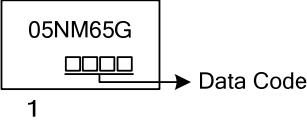
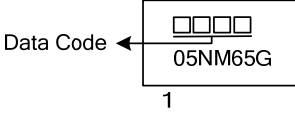
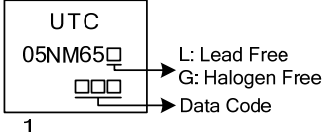
PACKAGE	MARKING
SOT-223	
SOT-89	
TO-92	

■ ABSOLUTE MAXIMUM RATINGS ( $T_c=25^\circ\text{C}$ , unless otherwise specified)

PARAMETER		SYMBOL	RATINGS	UNIT
Drain-Source Voltage		$V_{DSS}$	650	V
Gate-Source Voltage		$V_{GSS}$	$\pm 30$	V
Drain Current	Continuous	$I_D$	0.5	A
	Pulsed (Note 2)	$I_{DM}$	1.2	A
Power Dissipation	SOT-223	$P_D$	9	W
	SOT-89		3.3	W
	TO-92		1.4	W
Junction Temperature		$T_J$	150	$^\circ\text{C}$
Storage Temperature Range		$T_{STG}$	-55 ~ +150	$^\circ\text{C}$

Notes: 1. Absolute maximum ratings are those values beyond which the device could be permanently damaged. Absolute maximum ratings are stress ratings only and functional device operation is not implied.  
2. Repetitive Rating : Pulse width limited by maximum junction temperature.

■ THERMAL DATA

PARAMETER		SYMBOL	RATINGS	UNIT
Junction to Ambient	SOT-223	$\theta_{JA}$	150	$^\circ\text{C/W}$
	SOT-89		180	$^\circ\text{C/W}$
	SOT-92			
Junction to Case	SOT-223	$\theta_{JC}$	14	$^\circ\text{C/W}$
	SOT-89		38	$^\circ\text{C/W}$
	SOT-92		88	$^\circ\text{C/W}$

■ ELECTRICAL CHARACTERISTICS ( $T_J = 25^\circ\text{C}$ , unless otherwise specified)

PARAMETER		SYMBOL	TEST CONDITIONS	MIN	TYP	MAX	UNIT
<b>OFF CHARACTERISTICS</b>							
Drain-Source Breakdown Voltage		$BV_{DSS}$	$I_D=250\mu\text{A}$ , $V_{GS}=0\text{V}$	650			V
Drain-Source Leakage Current		$I_{DSS}$	$V_{DS}=650\text{V}$ , $V_{GS}=0\text{V}$			10	$\mu\text{A}$
Gate-Source Leakage Current	Forward	$I_{GSS}$	$V_{GS}=+30\text{V}$ , $V_{DS}=0\text{V}$			+100	nA
	Reverse		$V_{GS}=-30\text{V}$ , $V_{DS}=0\text{V}$			-100	nA
<b>ON CHARACTERISTICS</b>							
Gate Threshold Voltage		$V_{GS(TH)}$	$V_{DS}=V_{GS}$ , $I_D=250\mu\text{A}$	2.5		4.5	V
Static Drain-Source On-State Resistance		$R_{DS(ON)}$	$V_{GS}=10\text{V}$ , $I_D=0.25\text{A}$			13	$\Omega$
<b>DYNAMIC PARAMETERS</b>							
Input Capacitance		$C_{ISS}$	$V_{GS}=0\text{V}$ , $V_{DS}=25\text{V}$ , $f=1.0\text{MHz}$		38		pF
Output Capacitance		$C_{OSS}$			24		pF
Reverse Transfer Capacitance		$C_{RSS}$			4		pF
<b>SWITCHING PARAMETERS</b>							
Total Gate Charge (Note 1)		$Q_G$	$V_{DS}=50\text{V}$ , $V_{GS}=10\text{V}$ , $I_D=1.3\text{A}$ , $I_D=100\mu\text{A}$ (Note 1, 2)		7		nC
Gate to Source Charge		$Q_{GS}$			1		nC
Gate to Drain Charge		$Q_{GD}$			2		nC
Turn-ON Delay Time (Note 1)		$t_{D(ON)}$	$V_{DS}=30\text{V}$ , $V_{GS}=10\text{V}$ , $I_D=0.5\text{A}$ , $R_G=25\Omega$ (Note 1, 2)		26		ns
Rise Time		$t_R$			23		ns
Turn-OFF Delay Time		$t_{D(OFF)}$			30		ns
Fall-Time		$t_F$			30		ns
<b>SOURCE- DRAIN DIODE RATINGS AND CHARACTERISTICS</b>							
Maximum Body-Diode Continuous Current		$I_S$				0.5	A
Maximum Body-Diode Pulsed Current		$I_{SM}$				2.0	A
Drain-Source Diode Forward Voltage (Note 1)		$V_{SD}$	$I_S=0.5\text{A}$ , $V_{GS}=0\text{V}$			1.4	V

Notes: 1. Pulse Test: Pulse width  $\leq 300\mu\text{s}$ , Duty cycle  $\leq 2\%$ .  
2. Essentially independent of operating temperature.

■ TEST CIRCUITS AND WAVEFORMS

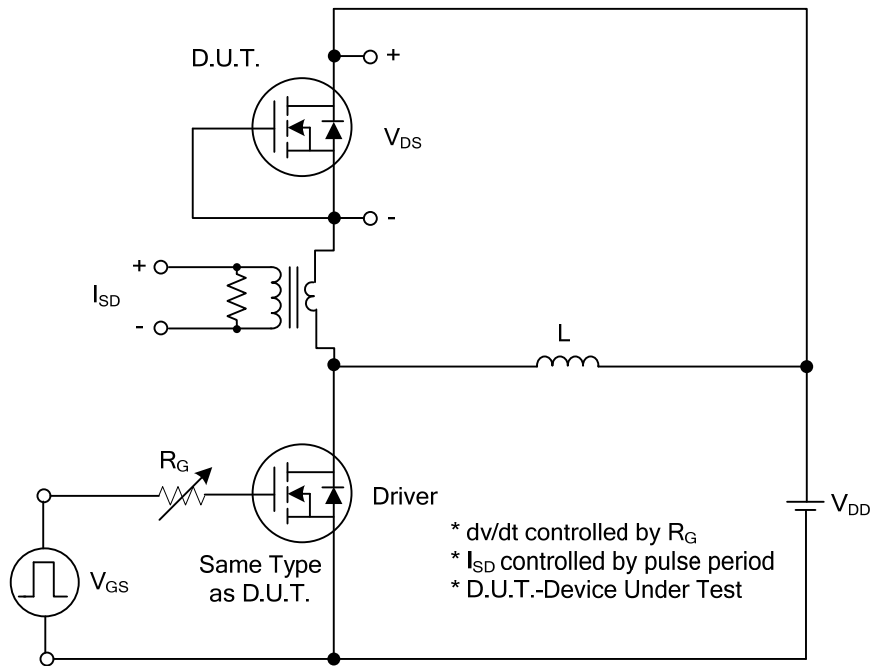

Peak Diode Recovery  $dv/dt$  Test Circuit

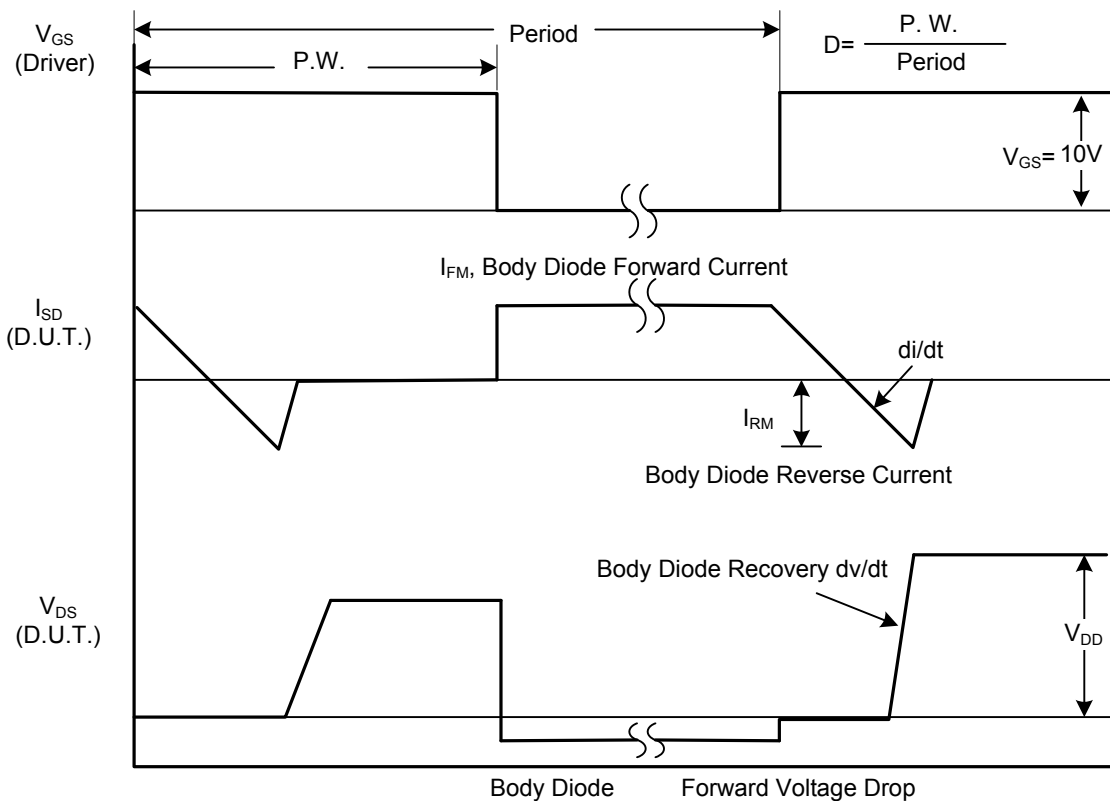

Peak Diode Recovery  $dv/dt$  Waveforms

■ TEST CIRCUITS AND WAVEFORMS (Cont.)

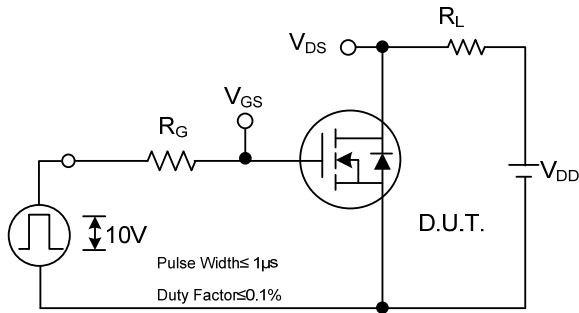

Switching Test Circuit

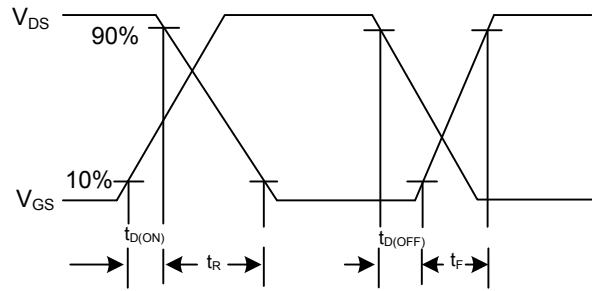

Switching Waveforms

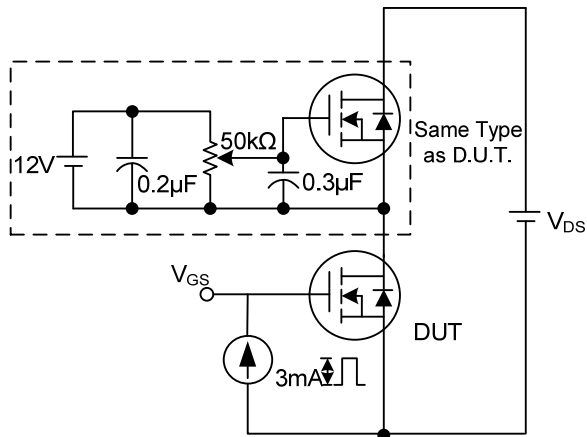

Gate Charge Test Circuit

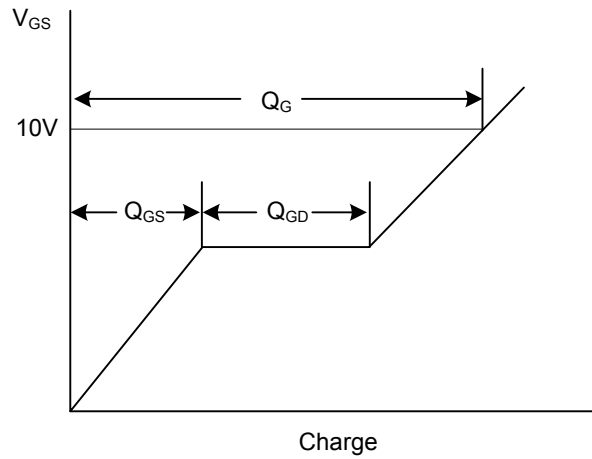

Gate Charge Waveform

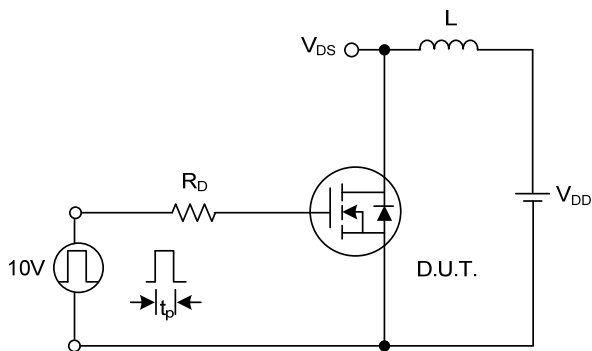

Unclamped Inductive Switching Test Circuit

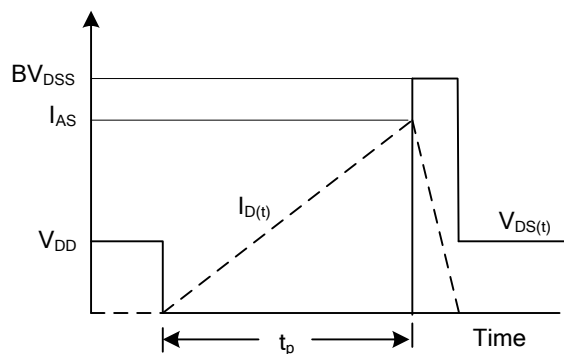

Unclamped Inductive Switching Waveforms

UTC assumes no responsibility for equipment failures that result from using products at values that exceed, even momentarily, rated values (such as maximum ratings, operating condition ranges, or other parameters) listed in products specifications of any and all UTC products described or contained herein. UTC products are not designed for use in life support appliances, devices or systems where malfunction of these products can be reasonably expected to result in personal injury. Reproduction in whole or in part is prohibited without the prior written consent of the copyright owner. The information presented in this document does not form part of any quotation or contract, is believed to be accurate and reliable and may be changed without notice.