



02NM60

Preliminary

Power MOSFET

0.2A, 600V N-CHANNEL SUPER-JUNCTION MOSFET

■ DESCRIPTION

The UTC **02NM60** is an Super Junction MOSFET Structure and is designed to have better characteristics, such as fast switching time, low gate charge, low on-state resistance and have a high rugged avalanche characteristics. This power MOSFET is usually used at high speed switching applications in power supplies, PWM motor controls, high efficient AC to DC converters and bridge circuits.

■ FEATURES

- * $R_{DS(on)} \leq 17 \Omega @ V_{GS}=10V, I_D=0.1A$
- * High breakdown voltage

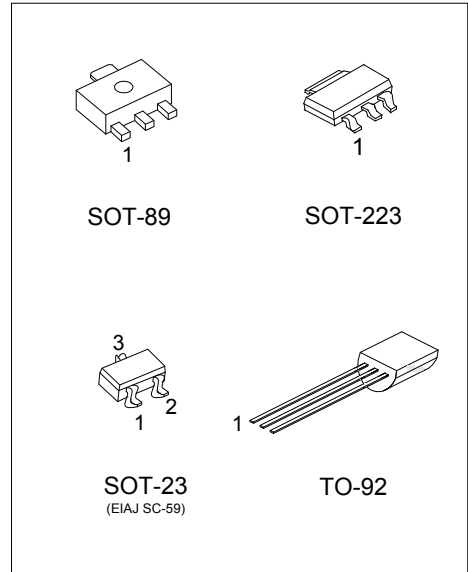

■ ORDERING INFORMATION

Order Number		Package	Pin Assignment			Packing
Lead Free	Halogen Free		1	2	3	
02NM60L-AA3-R	02NM60G-AA3-R	SOT-223	G	D	S	Tape Reel
02NM60L-AB3-R	02NM60G-AB3-R	SOT-89	G	D	S	Tape Reel
02NM60L-AE3-R	02NM60G-AE3-R	SOT-23	G	S	D	Tape Reel
02NM60L-T92-B	02NM60G-T92-B	TO-92	G	D	S	Tape Box
02NM60L-T92-K	02NM60G-T92-K	TO-92	G	D	S	Bulk

Note: Pin Assignment: G: Gate D: Drain S: Source

<p>02NM60G-AA3-R</p>	<p>(1) R: Tape Reel, B: Tape Box, K: Bulk (2) AA3: SOT-223, AB3: SOT-89, AE3: SOT-23 T92: TO-92 (3) G: Halogen Free and Lead Free, L: Lead Free</p>
----------------------	--

■ MARKING

<p>SOT-223</p>	<p>SOT-89</p>
<p>SOT-23</p>	<p>TO-92</p>

■ ABSOLUTE MAXIMUM RATINGS ($T_C=25^\circ\text{C}$, unless otherwise specified)

PARAMETER		SYMBOL	RATINGS	UNIT
Drain-Source Voltage		V_{DSS}	600	V
Gate-Source Voltage		V_{GSS}	± 30	V
Drain Current	Continuous	I_D	0.2	A
	Pulsed (Note 2)	I_{DM}	0.8	A
Power Dissipation	SOT-223	P_D	3	W
	SOT-89		1.6	W
	SOT-23		1.2	W
	TO-92		2.5	W
Junction Temperature		T_J	150	$^\circ\text{C}$
Storage Temperature Range		T_{STG}	-55 ~ +150	$^\circ\text{C}$

Notes: 1. Absolute maximum ratings are those values beyond which the device could be permanently damaged.

Absolute maximum ratings are stress ratings only and functional device operation is not implied.

2. Repetitive Rating: Pulse width limited by maximum junction temperature.

■ THERMAL DATA

PARAMETER		SYMBOL	RATINGS	UNIT
Junction to Ambient	SOT-223	θ_{JA}	150	$^\circ\text{C/W}$
	SOT-89		180	$^\circ\text{C/W}$
	SOT-23		325	$^\circ\text{C/W}$
	TO-92		160	$^\circ\text{C/W}$
Junction to Case	SOT-223	θ_{JC}	41.6	$^\circ\text{C/W}$
	SOT-89		78	$^\circ\text{C/W}$
	SOT-23		104	$^\circ\text{C/W}$
	TO-92		50	$^\circ\text{C/W}$

Note: Device mounted on FR-4 substrate PC board, 2oz copper, with 1inch square copper plate.

■ ELECTRICAL CHARACTERISTICS ($T_J=25^\circ\text{C}$, unless otherwise specified)

PARAMETER	SYMBOL	TEST CONDITIONS	MIN	TYP	MAX	UNIT
OFF CHARACTERISTICS						
Drain-Source Breakdown Voltage	BV_{DSS}	$I_D=250\mu\text{A}$, $V_{GS}=0\text{V}$	600			V
Drain-Source Leakage Current	I_{DSS}	$V_{DS}=600\text{V}$, $V_{GS}=0\text{V}$			10	μA
Gate-Source Leakage Current	Forward	$V_{GS}=+30\text{V}$, $V_{DS}=0\text{V}$			+100	nA
	Reverse	$V_{GS}=-30\text{V}$, $V_{DS}=0\text{V}$			-100	nA
ON CHARACTERISTICS						
Gate Threshold Voltage	$V_{GS(TH)}$	$V_{DS}=V_{GS}$, $I_D=250\mu\text{A}$	2.5		4.5	V
Static Drain-Source On-State Resistance	$R_{DS(ON)}$	$V_{GS}=10\text{V}$, $I_D=0.1\text{A}$			17	Ω
DYNAMIC PARAMETERS						
Input Capacitance	C_{ISS}	$V_{GS}=0\text{V}$, $V_{DS}=50\text{V}$, $f=1.0\text{MHz}$		26		pF
Output Capacitance	C_{OSS}			13.5		pF
Reverse Transfer Capacitance	C_{RSS}			3.5		pF
SWITCHING PARAMETERS						
Total Gate Charge (Note 1)	Q_G	$V_{DS}=480\text{V}$, $V_{GS}=10\text{V}$, $I_D=0.2\text{A}$ (Note 1, 2)		9		nC
Gate to Source Charge	Q_{GS}			3.2		nC
Gate to Drain Charge	Q_{GD}			1.5		nC
Turn-ON Delay Time (Note 1)	$t_{D(ON)}$	$V_{DS}=100\text{V}$, $V_{GS}=10\text{V}$, $I_D=0.2\text{A}$, $R_G=25\Omega$ (Note 1, 2)		4		ns
Rise Time	t_R			18		ns
Turn-OFF Delay Time	$t_{D(OFF)}$			25		ns
Fall-Time	t_F			180		ns
SOURCE- DRAIN DIODE RATINGS AND CHARACTERISTICS						
Maximum Body-Diode Continuous Current	I_S				0.2	A
Maximum Body-Diode Pulsed Current	I_{SM}				0.8	A
Drain-Source Diode Forward Voltage (Note 1)	V_{SD}	$I_S=0.2\text{A}$, $V_{GS}=0\text{V}$			1.4	V
Reverse Recovery Time (Note 1)	t_{rr}	$I_S=0.2\text{A}$, $V_{GS}=0\text{V}$		102		ns
Reverse Recovery Charge	Q_{rr}	$di/dt=100\text{A}/\mu\text{s}$		106		nC

Notes: 1. Pulse Test: Pulse width $\leq 300\mu\text{s}$, Duty cycle $\leq 2\%$.

2. Essentially independent of operating temperature.

■ TEST CIRCUITS AND WAVEFORMS

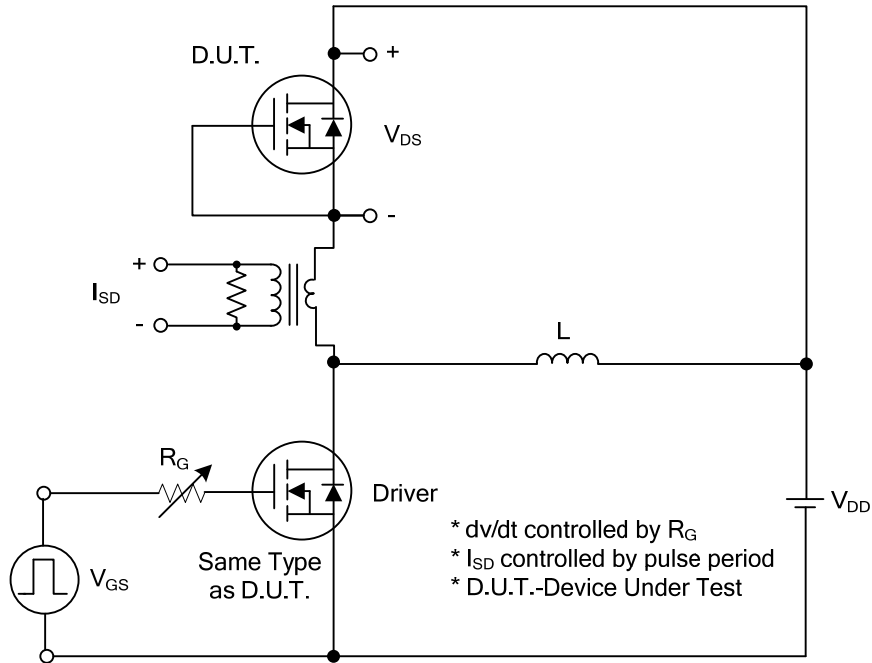

Peak Diode Recovery dv/dt Test Circuit

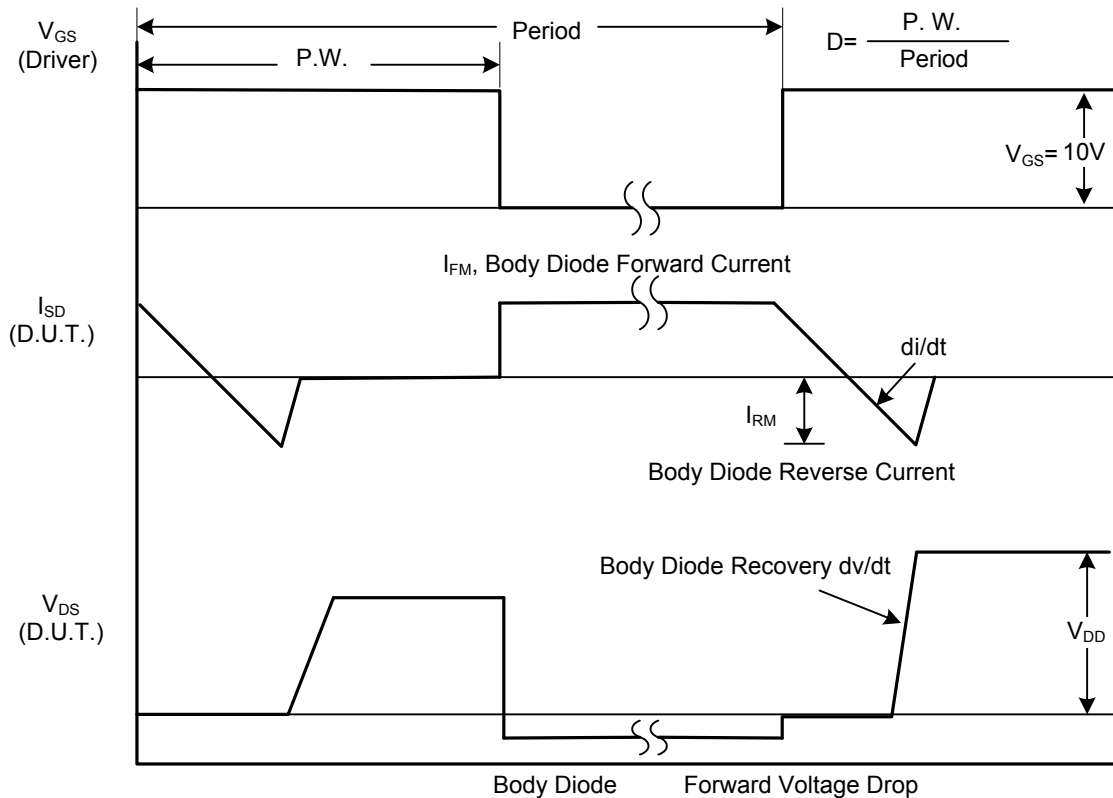

Peak Diode Recovery dv/dt Waveforms

■ TEST CIRCUITS AND WAVEFORMS

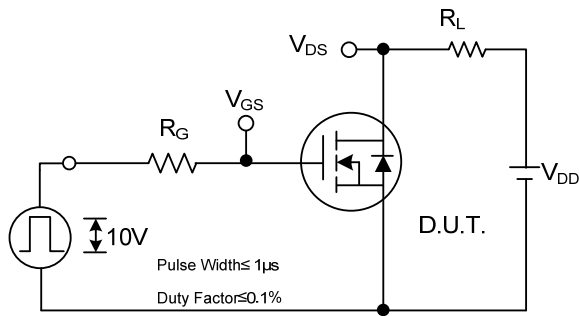

Switching Test Circuit

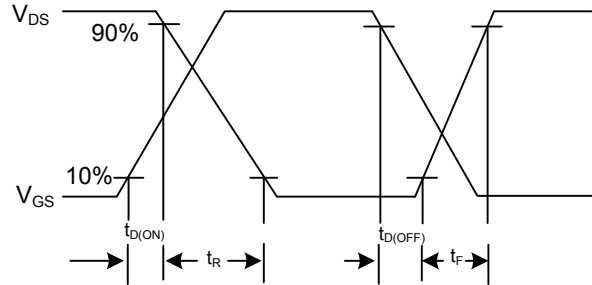

Switching Waveforms

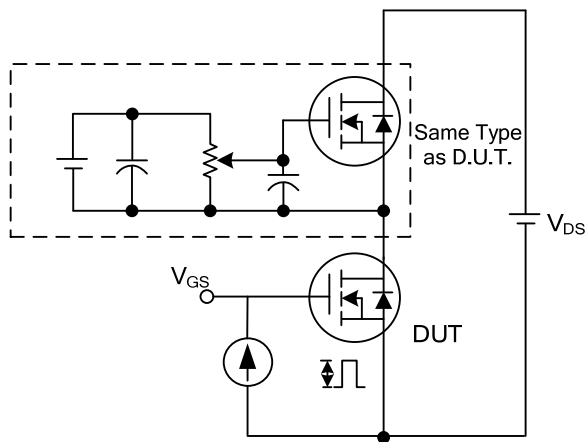

Gate Charge Test Circuit

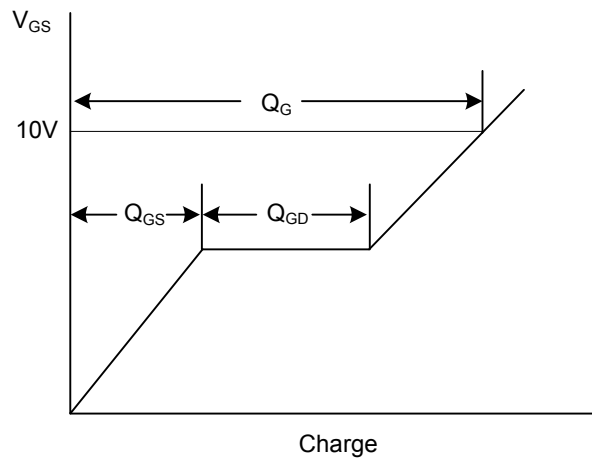

Gate Charge Waveform

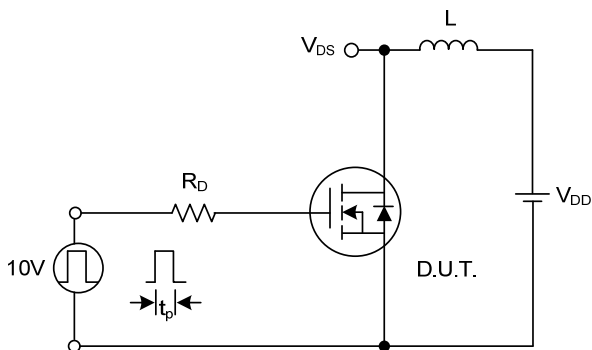

Unclamped Inductive Switching Test Circuit

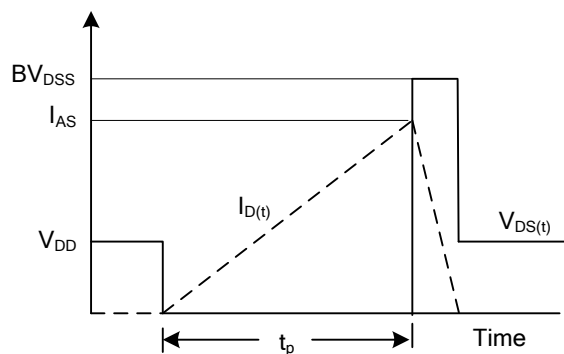

Unclamped Inductive Switching Waveforms

UTC assumes no responsibility for equipment failures that result from using products at values that exceed, even momentarily, rated values (such as maximum ratings, operating condition ranges, or other parameters) listed in products specifications of any and all UTC products described or contained herein. UTC products are not designed for use in life support appliances, devices or systems where malfunction of these products can be reasonably expected to result in personal injury. Reproduction in whole or in part is prohibited without the prior written consent of the copyright owner. UTC reserves the right to make changes to information published in this document, including without limitation specifications and product descriptions, at any time and without notice. This document supersedes and replaces all information supplied prior to the publication hereof.