



# 12NM90

**Power MOSFET**

## 12A, 900V N-CHANNEL SUPER-JUNCTION MOSFET

### DESCRIPTION

The **UTC 12NM90** is a Super Junction MOSFET Structure and is designed to have better characteristics, such as fast switching time, low gate charge, low on-state resistance and a high rugged avalanche characteristics. This power MOSFET is usually used at AC-DC converters for power applications.

### FEATURES

- \*  $R_{DS(ON)} \leq 0.7 \Omega @ V_{GS}=10V, I_D=6.0A$
- \* Fast switching capability
- \* Avalanche energy tested
- \* Improved dv/dt capability, high ruggedness

### SYMBOL

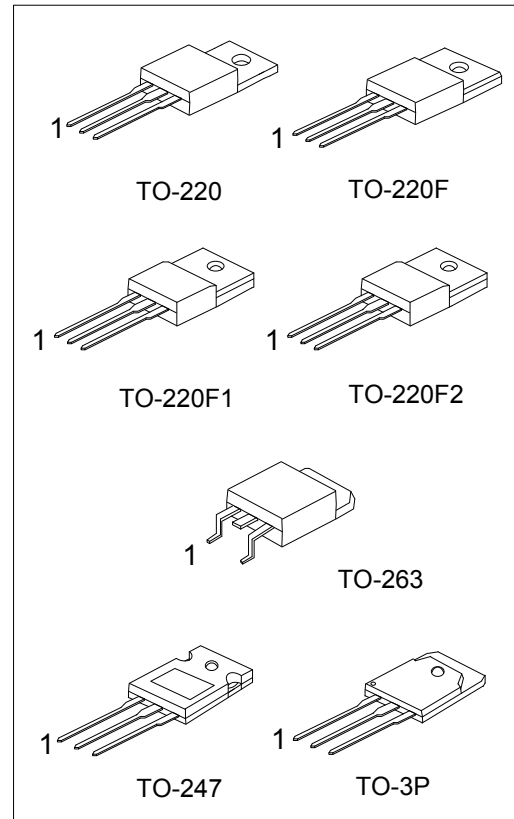
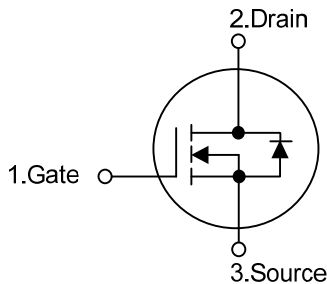

### ORDERING INFORMATION

Ordering Number		Package	Pin Assignment			Packing
Lead Free	Halogen Free		1	2	3	
12NM90L-TA3-T	12NM90G-TA3-T	TO-220	G	D	S	Tube
12NM90L-TF1-T	12NM90G-TF1-T	TO-220F1	G	D	S	Tube
12NM90L-TF2-T	12NM90G-TF2-T	TO-220F2	G	D	S	Tube
12NM90L-TF3-T	12NM90G-TF3-T	TO-220F	G	D	S	Tube
12NM90L-TQ2-T	12NM90G-TQ2-T	TO-263	G	D	S	Tube
12NM90L-TQ2-R	12NM90G-TQ2-R	TO-263	G	D	S	Tape Reel
12NM90L-T3P-T	12NM90G-T3P-T	TO-3P	G	D	S	Tube
12NM90L-T47-T	12NM90G-T47-T	TO-247	G	D	S	Tube

Note: Pin Assignment: G: Gate D: Drain S: Source

<p>12NM90G-TA3-T</p>	<p>(1) T: Tube, R: Tape Reel                  (2) TA3: TO-220, TF1: TO-220F1, TF2: TO-220F2                  TF3: TO-220F, TQ2: TO-263, T3P: TO-3P                  T47: TO-247                  (3) G: Halogen Free and Lead Free, L: Lead Free</p>
----------------------	--

■ MARKING

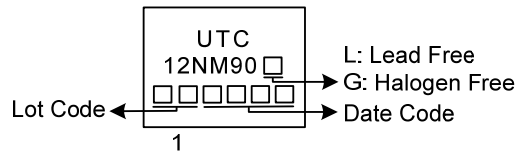

■ ABSOLUTE MAXIMUM RATINGS ( $T_C=25^\circ\text{C}$ , unless otherwise specified)

PARAMETER		SYMBOL	RATINGS	UNIT
Drain-Source Voltage		$V_{DSS}$	900	V
Gate-Source Voltage		$V_{GSS}$	$\pm 30$	V
Continuous Drain Current	Continuous	$I_D$	12	A
Pulsed Drain Current	Pulsed (Note 2)	$I_{DM}$	24	A
Single Pulsed Avalanche Energy	Single Pulsed (Note 3)	$E_{AS}$	156	mJ
Peak Diode Recovery dv/dt (Note 4)		dv/dt	2	V/ns
Power Dissipation	TO-220/TO-263	$P_D$	90	W
	TO-220F/TO-220F1		31	W
	TO-220F2			
	TO-247			
	TO-3P			
Junction Temperature		$T_J$	+150	$^\circ\text{C}$
Storage Temperature		$T_{STG}$	-55 ~ +150	$^\circ\text{C}$

Notes: 1. Absolute maximum ratings are those values beyond which the device could be permanently damaged.

Absolute maximum ratings are stress ratings only and functional device operation is not implied.

2. Repetitive Rating: Pulse width limited by maximum junction temperature.

3.  $L = 10\text{mH}$ ,  $I_{AS} = 5.6\text{A}$ ,  $V_{DD} = 50\text{V}$ ,  $R_G = 25\Omega$ , Starting  $T_J = 25^\circ\text{C}$ .

4.  $I_{SD} \leq 12\text{A}$ ,  $di/dt \leq 200\text{A}/\mu\text{s}$ ,  $V_{DD} \leq BV_{DSS}$ , Starting  $T_J = 25^\circ\text{C}$ .

■ THERMAL DATA

PARAMETER		SYMBOL	RATINGS	UNIT
Junction to Ambient	TO-220/TO-220F	$\theta_{JA}$	62.5	$^\circ\text{C}/\text{W}$
	TO-220F1/TO-220F2			
	TO-263			
	TO-247			
	TO-3P			
Junction to Case	TO-220/TO-263	$\theta_{JC}$	1.39	$^\circ\text{C}/\text{W}$
	TO-220F/TO-220F1		4.03	$^\circ\text{C}/\text{W}$
	TO-220F2			
	TO-247			
	TO-3P			
		0.66	$^\circ\text{C}/\text{W}$	

■ ELECTRICAL CHARACTERISTICS (T<sub>J</sub>=25°C, unless otherwise specified)

PARAMETER	SYMBOL	TEST CONDITIONS	MIN	TYP	MAX	UNIT
<b>OFF CHARACTERISTICS</b>						
Drain-Source Breakdown Voltage	BV <sub>DSS</sub>	V <sub>GS</sub> =0V, I <sub>D</sub> =250μA	900			V
Drain-Source Leakage Current	I <sub>DSS</sub>	V <sub>DS</sub> =900V, V <sub>GS</sub> =0V			10	μA
Gate-Source Leakage Current	Forward	I <sub>GSS</sub>			100	nA
	Reverse					
		V <sub>GS</sub> =-30V, V <sub>DS</sub> =0V			-100	nA
<b>ON CHARACTERISTICS</b>						
Gate Threshold Voltage	V <sub>GS(TH)</sub>	V <sub>DS</sub> =V <sub>GS</sub> , I <sub>D</sub> =250μA	2.5		4.5	V
Static Drain-Source On-State Resistance	R <sub>DS(ON)</sub>	V <sub>GS</sub> =10V, I <sub>D</sub> =6.0A			0.7	Ω
<b>DYNAMIC CHARACTERISTICS</b>						
Input Capacitance	C <sub>ISS</sub>	V <sub>GS</sub> =0V, V <sub>DS</sub> =25V, f=1.0MHz		1230		pF
Output Capacitance	C <sub>OSS</sub>			820		pF
Reverse Transfer Capacitance	C <sub>RSS</sub>			30		pF
<b>SWITCHING CHARACTERISTICS</b>						
Total Gate Charge (Note 1)	Q <sub>G</sub>	V <sub>DS</sub> =720V, I <sub>D</sub> =12A, I <sub>G</sub> =1mA V <sub>GS</sub> =10V (Note 1,2)		50		nC
Gate to Source Charge	Q <sub>GS</sub>			8		nC
Gate to Drain Charge	Q <sub>GD</sub>			16		nC
Turn-ON Delay Time (Note 1)	t <sub>D(ON)</sub>	V <sub>DD</sub> =100V, I <sub>D</sub> =12A, R <sub>G</sub> =25Ω, V <sub>GS</sub> =10V (Note 1,2)		22		nS
Rise Time	t <sub>R</sub>			23		nS
Turn-OFF Delay Time	t <sub>D(OFF)</sub>			150		nS
Fall-Time	t <sub>F</sub>			50		nS
<b>SOURCE- DRAIN DIODE RATINGS AND CHARACTERISTICS</b>						
Maximum Body-Diode Continuous Current	I <sub>S</sub>				12	A
Maximum Body-Diode Pulsed Current	I <sub>SM</sub>				24	A
Drain-Source Diode Forward Voltage (Note 1)	V <sub>SD</sub>	I <sub>S</sub> =12A, V <sub>GS</sub> =0V			1.4	V
Body Diode Reverse Recovery Time (Note 1)	t <sub>rr</sub>	I <sub>S</sub> =12A, V <sub>GS</sub> =0V, dI <sub>F</sub> /dt=100A/μs		595		nS
Body Diode Reverse Recovery Charge	Q <sub>rr</sub>				10.4	

Notes: 1. Pulse Test : Pulse width ≤ 300μs, Duty cycle ≤ 2%.

2. Essentially independent of operating ambient temperature.

## ■ TEST CIRCUITS AND WAVEFORMS

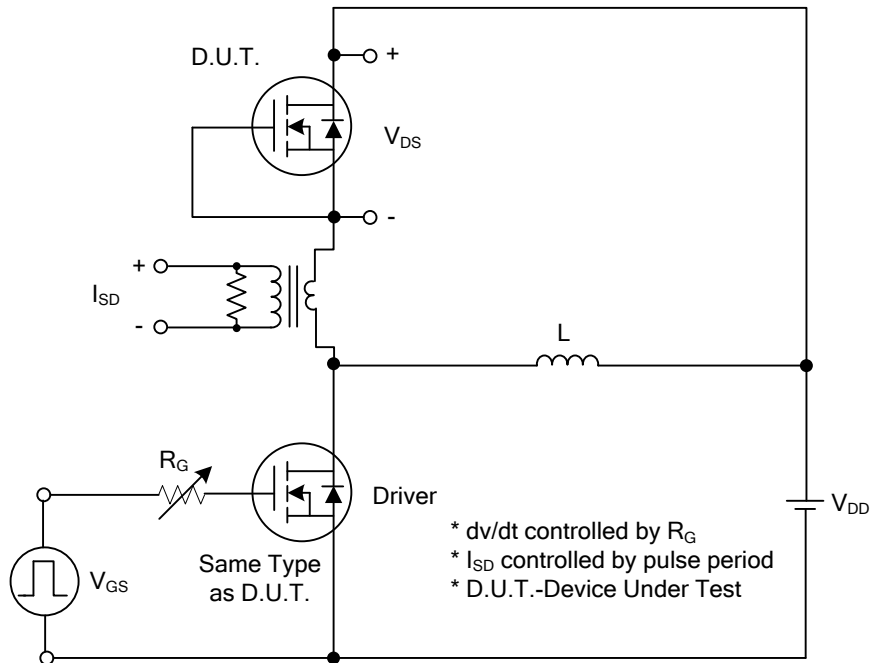

**Peak Diode Recovery  $dv/dt$  Test Circuit**

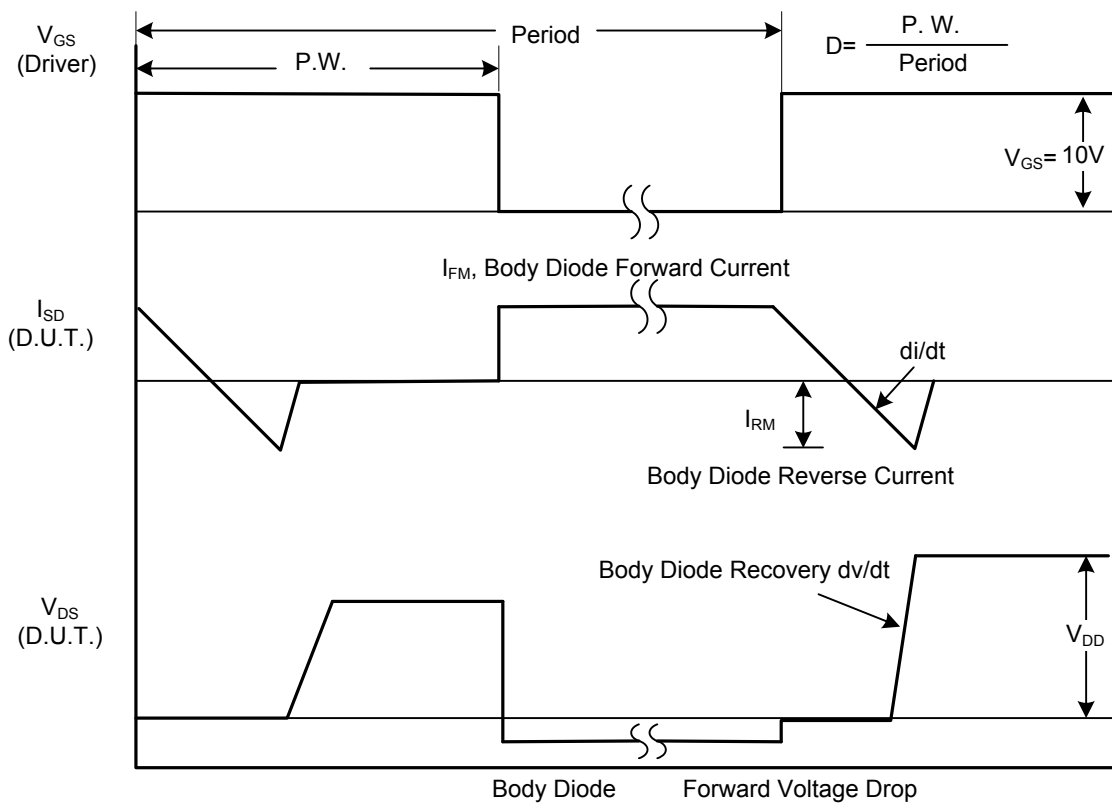

**Peak Diode Recovery  $dv/dt$  Waveforms**

## TEST CIRCUITS AND WAVEFORMS

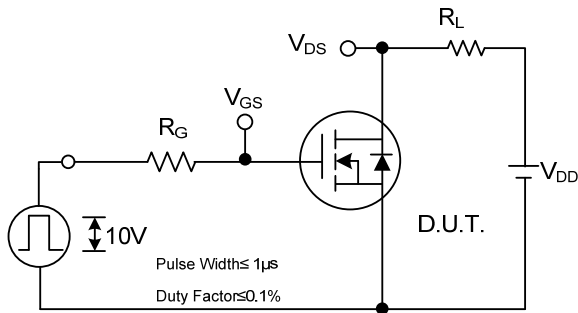

**Switching Test Circuit**



**Switching Waveforms**

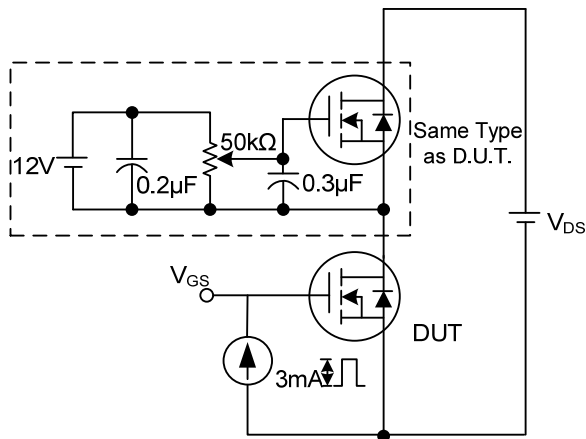

**Gate Charge Test Circuit**



**Gate Charge Waveform**

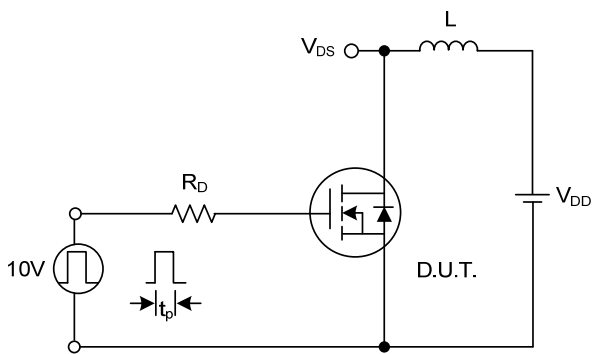

**Unclamped Inductive Switching Test Circuit**

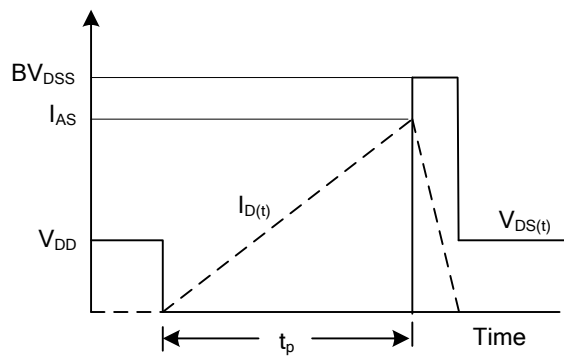

**Unclamped Inductive Switching Waveforms**

### TYPICAL CHARACTERISTICS

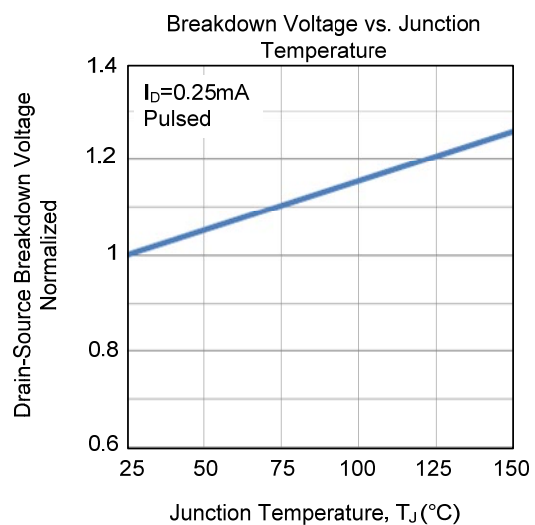
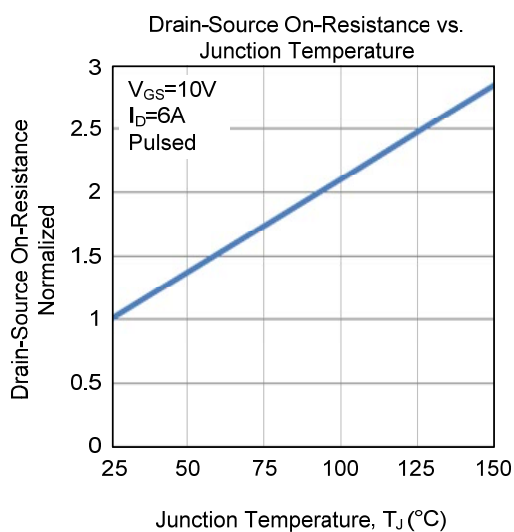
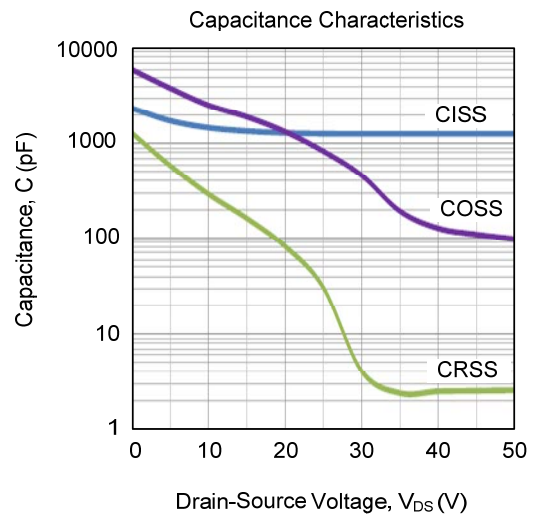
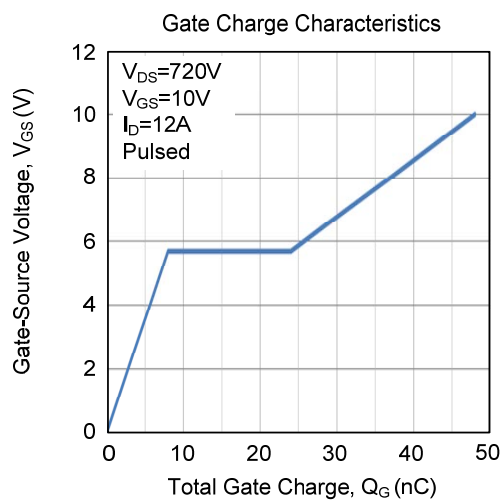
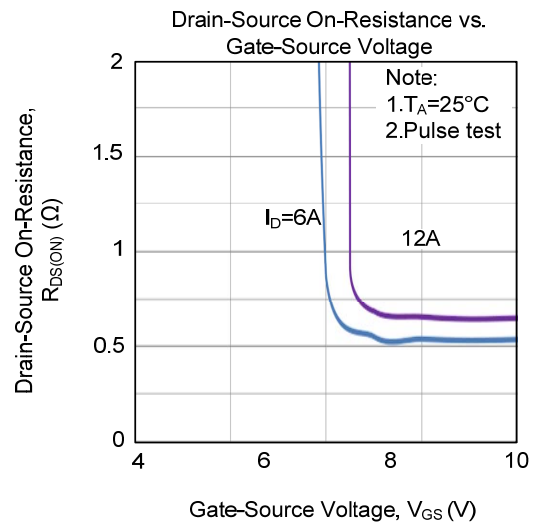
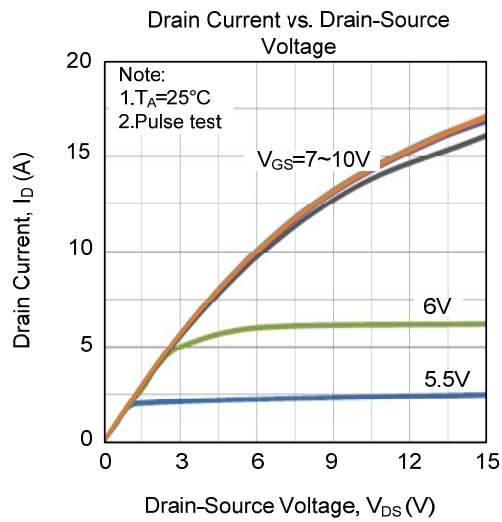

### ■ TYPICAL CHARACTERISTICS (Cont.)

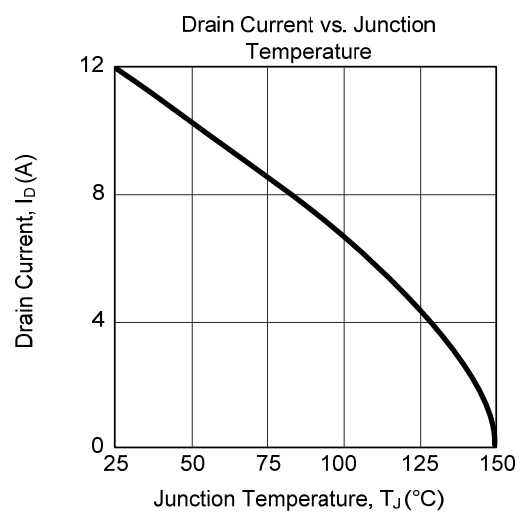
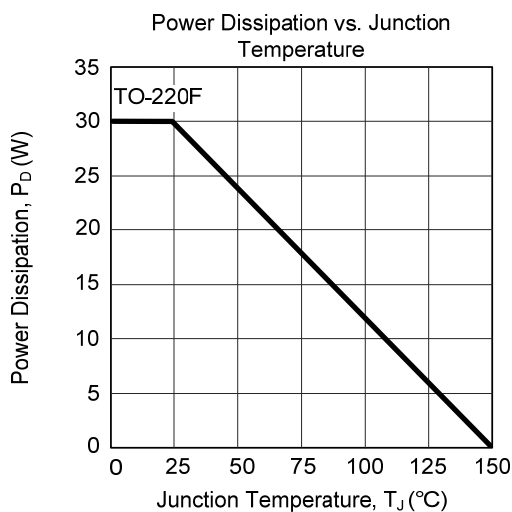
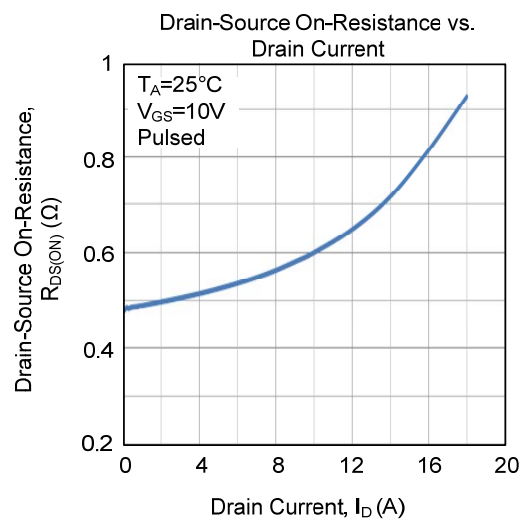
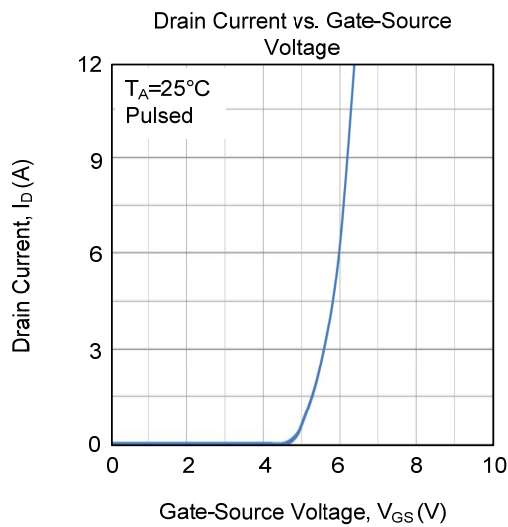
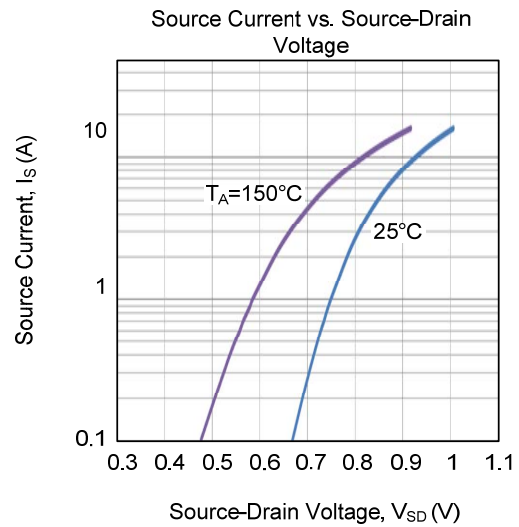
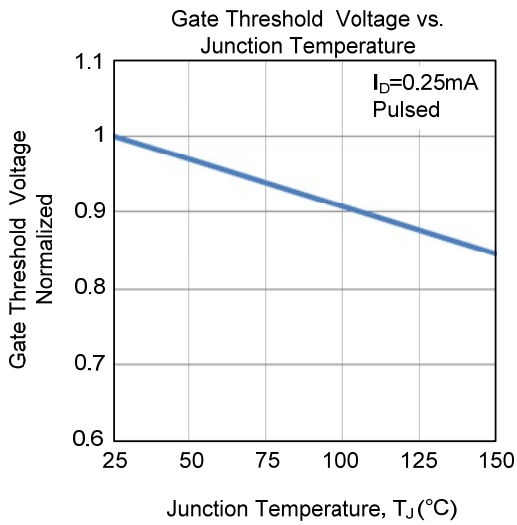



■ TYPICAL CHARACTERISTICS (Cont.)

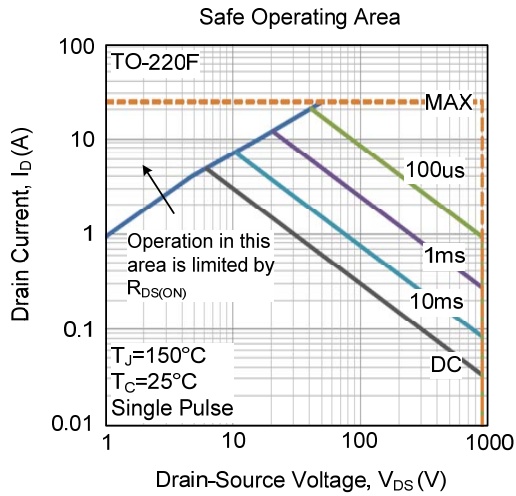

UTC assumes no responsibility for equipment failures that result from using products at values that exceed, even momentarily, rated values (such as maximum ratings, operating condition ranges, or other parameters) listed in products specifications of any and all UTC products described or contained herein. UTC products are not designed for use in life support appliances, devices or systems where malfunction of these products can be reasonably expected to result in personal injury. Reproduction in whole or in part is prohibited without the prior written consent of the copyright owner. UTC reserves the right to make changes to information published in this document, including without limitation specifications and product descriptions, at any time and without notice. This document supersedes and replaces all information supplied prior to the publication hereof.