



## 4NM90

Preliminary

Power MOSFET

### 4A, 900V N-CHANNEL SUPER-JUNCTION MOSFET

#### DESCRIPTION

The UTC 4NM90 is a Super Junction MOSFET Structure and is designed to have better characteristics, such as fast switching time, low gate charge, low on-state resistance and a high rugged avalanche characteristics. This power MOSFET is usually used at AC-DC converters for power applications.

#### FEATURES

- \*  $R_{DS(ON)} \leq 4.1 \Omega @ V_{GS}=10V, I_D=2.0A$
- \* Fast switching capability
- \* Avalanche energy tested
- \* Improved dv/dt capability, high ruggedness

#### SYMBOL

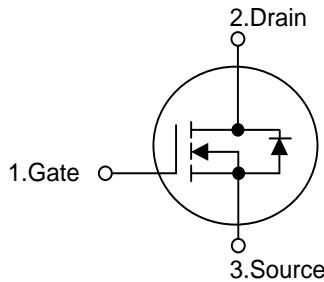

#### ORDERING INFORMATION

Ordering Number		Package	Pin Assignment			Packing
Lead Free	Halogen Free		1	2	3	
4NM90L-AA2-R	4NM90G-AA2-R	SOT-223-2	G	D	S	Tape Reel
4NM90L-AA3-R	4NM90G-AA3-R	SOT-223	G	D	S	Tape Reel
4NM90L-TA3-T	4NM90G-TA3-T	TO-220	G	D	S	Tube
4NM90L-TF1-T	4NM90G-TF1-T	TO-220F1	G	D	S	Tube
4NM90L-TF2-T	4NM90G-TF2-T	TO-220F2	G	D	S	Tube
4NM90L-TM3-T	4NM90G-TM3-T	TO-251	G	D	S	Tube
4NM90L-TMS2-T	4NM90G-TMS2-T	TO-251S2	G	D	S	Tube
4NM90L-TN3-R	4NM90G-TN3-R	TO-252	G	D	S	Tape Reel

Note: Pin Assignment: G: Gate D: Drain S: Source

<p>4NM90G-AA3-R</p> <p>(1)Packing Type</p> <p>(2)Package Type</p> <p>(3)Green Package</p>	<p>(1) R: Tape Reel, T: Tube</p> <p>(2) AA2: SOT-223-2, AA3: SOT-223, TA3: TO-220, TF1: TO-220F1, TF2: TO-220F2, TM3: TO-251, TMS2: TO-251S2, TN3: TO-252</p> <p>(3) G: Halogen Free and Lead Free, L: Lead Free</p>
---	--

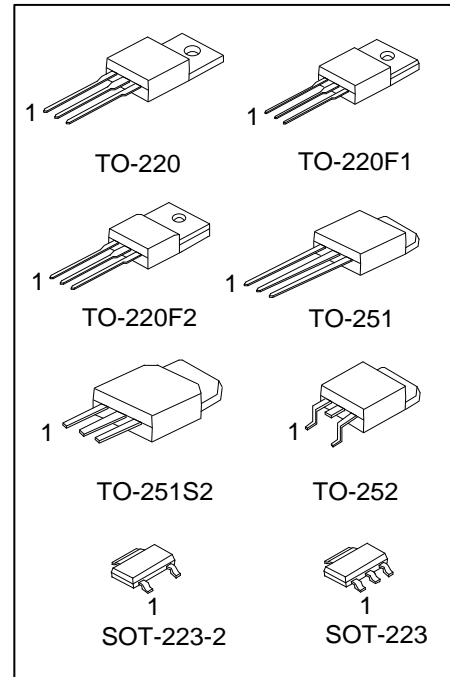

■ MARKING

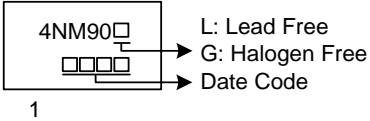
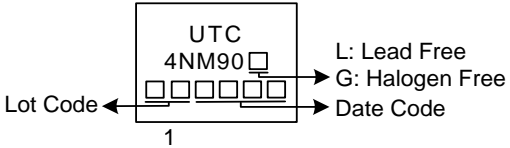
SOT-223-2 / SOT-223	TO-220 / TO-220F1 / TO-220F2 TO-251 / TO-251S2 / TO-252
 <p>4NM90 □ □□□□ 1</p> <p>L: Lead Free G: Halogen Free Date Code</p>	 <p>UTC 4NM90 □ □□□□ 1</p> <p>Lot Code ←</p> <p>L: Lead Free G: Halogen Free Date Code</p>

■ **ABSOLUTE MAXIMUM RATINGS** ( $T_C = 25^\circ\text{C}$ , unless otherwise specified)

PARAMETER		SYMBOL	RATINGS	UNIT
Drain-Source Voltage		$V_{DSS}$	900	V
Gate-Source Voltage		$V_{GSS}$	$\pm 30$	V
Continuous Drain Current	Continuous	$I_D$	4.0	A
Pulsed Drain Current	Pulsed (Note 2)	$I_{DM}$	16	A
Avalanche Current (Note 2)		$I_{AR}$	1.2	A
Single Pulsed Avalanche Energy	Single Pulsed (Note 3)	$E_{AS}$	114	mJ
Peak Diode Recovery dv/dt (Note 4)		dv/dt	1.34	V/ns
Power Dissipation	SOT-223-2/SOT-223	$P_D$	8	W
	TO-220		40	W
	TO-220F1/TO-220F2		22	W
	TO-251/TO-251S2		23	W
	TO-252			
Junction Temperature		$T_J$	+150	$^\circ\text{C}$
Storage Temperature		$T_{STG}$	-55 ~ +150	$^\circ\text{C}$

Notes: 1. Absolute maximum ratings are those values beyond which the device could be permanently damaged.

Absolute maximum ratings are stress ratings only and functional device operation is not implied.

2. Repetitive Rating: Pulse width limited by maximum junction temperature.

3.  $L = 159\text{mH}$ ,  $I_{AS} = 1.2\text{A}$ ,  $V_{DD} = 50\text{V}$ ,  $R_G = 25\Omega$ , Starting  $T_J = 25^\circ\text{C}$ .

4.  $I_{SD} \leq 4.0\text{A}$ ,  $di/dt \leq 200\text{A}/\mu\text{s}$ ,  $V_{DD} \leq BV_{DSS}$ , Starting  $T_J = 25^\circ\text{C}$ .

■ **THERMAL DATA**

PARAMETER		SYMBOL	RATING	UNIT
Junction to Ambient	SOT-223-2/SOT-223	$\theta_{JA}$	150	$^\circ\text{C}/\text{W}$
	TO-220/TO-220F1		62.5	$^\circ\text{C}/\text{W}$
	TO-220F2			
	TO-251/TO-251S2 TO-252		110	$^\circ\text{C}/\text{W}$
Junction to Case	SOT-223-2/SOT-223	$\theta_{JC}$	44.6 (Note)	$^\circ\text{C}/\text{W}$
	TO-220		3.13	$^\circ\text{C}/\text{W}$
	TO-220F1/TO-220F2		5.68	$^\circ\text{C}/\text{W}$
	TO-251/TO-251S2		5.43 (Note)	$^\circ\text{C}/\text{W}$
	TO-252			

Note: Device mounted on FR-4 substrate PC board, 2oz copper, with 1inch square copper plate.

■ **ELECTRICAL CHARACTERISTICS** ( $T_J=25^\circ\text{C}$ , unless otherwise specified)

PARAMETER	SYMBOL	TEST CONDITIONS	MIN	TYP	MAX	UNIT
<b>OFF CHARACTERISTICS</b>						
Drain-Source Breakdown Voltage	$BV_{DSS}$	$V_{GS} = 0V, I_D = 250\mu A$	900			V
Drain-Source Leakage Current	$I_{DSS}$	$V_{DS} = 900V, V_{GS} = 0V$			10	$\mu A$
Gate-Source Leakage Current	Forward	$I_{GSS}$			100	nA
	Reverse				-100	nA
<b>ON CHARACTERISTICS</b>						
Gate Threshold Voltage	$V_{GS(TH)}$	$V_{DS} = V_{GS}, I_D = 250\mu A$	2.5		4.5	V
Static Drain-Source On-State Resistance	$R_{DS(ON)}$	$V_{GS} = 10V, I_D = 2.0A$			4.1	$\Omega$
<b>DYNAMIC CHARACTERISTICS</b>						
Input Capacitance	$C_{ISS}$	$V_{GS}=0V, V_{DS}=25V, f=1.0MHz$		280		pF
Output Capacitance	$C_{OSS}$			125		pF
Reverse Transfer Capacitance	$C_{RSS}$			7		pF
<b>SWITCHING CHARACTERISTICS</b>						
Total Gate Charge (Note 1)	$Q_G$	$V_{DS}=50V, I_D=1.3A, I_G=100\mu A$ $V_{GS}=10V$ (Note 1,2)		45		nC
Gate to Source Charge	$Q_{GS}$			4		nC
Gate to Drain Charge	$Q_{GD}$			8		nC
Turn-ON Delay Time (Note 1)	$t_{D(ON)}$	$V_{DD} = 30V, I_D = 0.5A, R_G = 25\Omega,$ $V_{GS}=10V$ (Note 1,2)		42		nS
Rise Time	$t_R$			55		nS
Turn-OFF Delay Time	$t_{D(OFF)}$			130		nS
Fall-Time	$t_F$			35		nS
<b>SOURCE- DRAIN DIODE RATINGS AND CHARACTERISTICS</b>						
Maximum Body-Diode Continuous Current	$I_S$				4	A
Maximum Body-Diode Pulsed Current	$I_{SM}$				16	A
Drain-Source Diode Forward Voltage (Note 1)	$V_{SD}$	$I_S=4.0A, V_{GS}=0V$			1.4	V
Body Diode Reverse Recovery Time (Note 1)	$t_{rr}$	$I_S=4.0A, V_{GS}=0V,$ $dI_F/dt=100A/\mu s$		530		nS
Body Diode Reverse Recovery Charge	$Q_{rr}$			3.75		$\mu C$

Notes: 1. Pulse Test : Pulse width  $\leq 300\mu s$ , Duty cycle  $\leq 2\%$ .

2. Essentially independent of operating ambient temperature.

■ TEST CIRCUITS AND WAVEFORMS

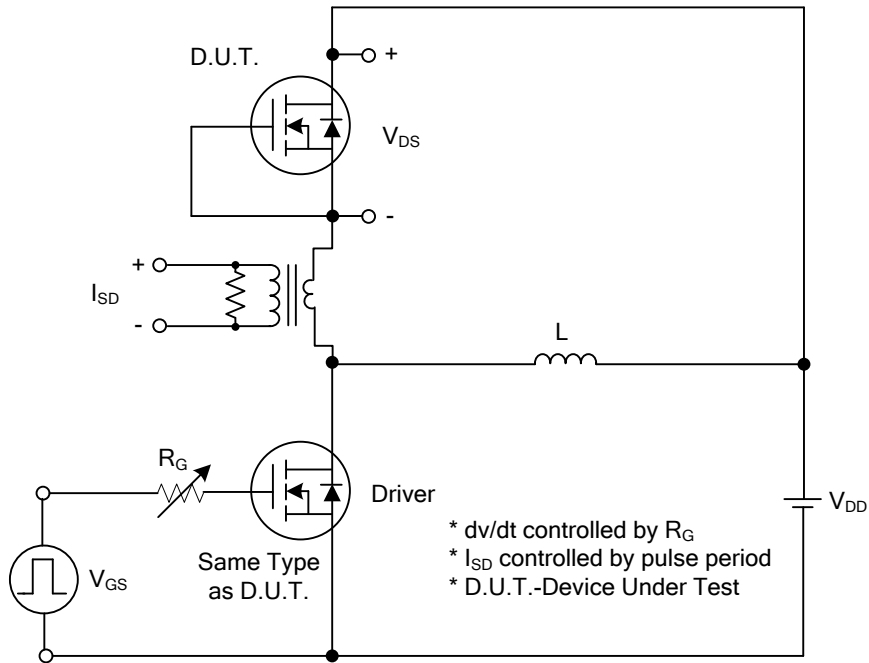

Peak Diode Recovery  $dv/dt$  Test Circuit

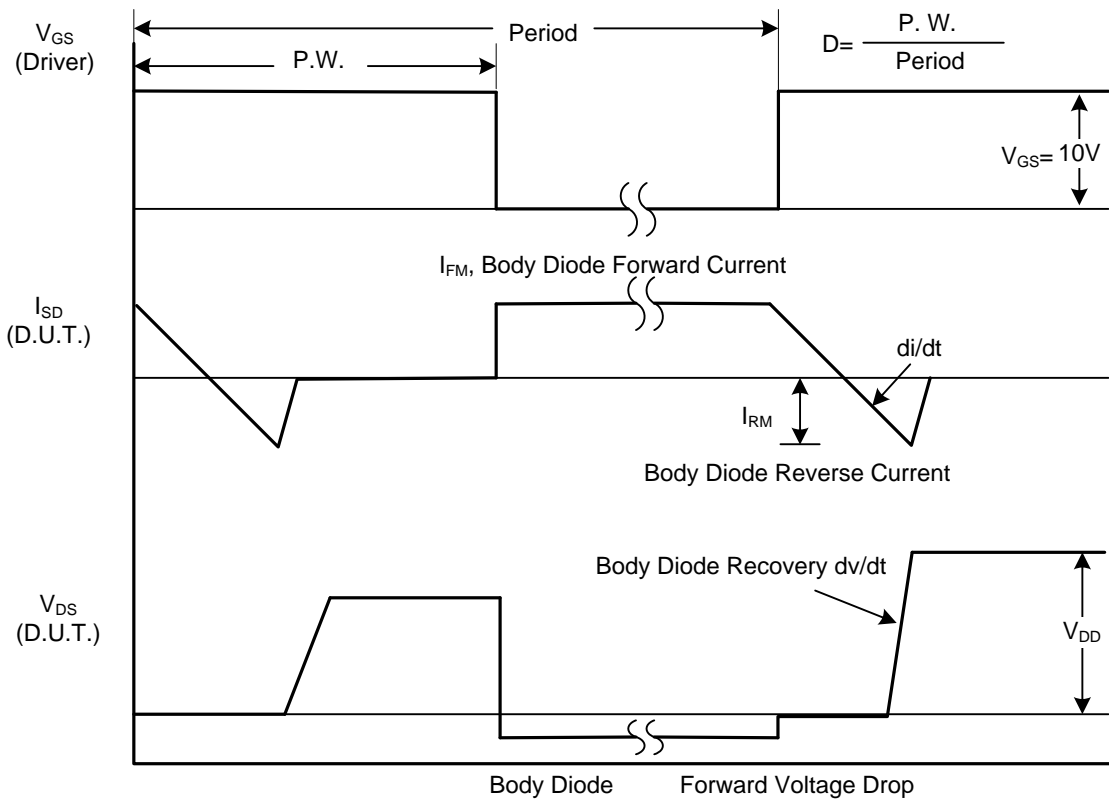

Peak Diode Recovery  $dv/dt$  Waveforms

■ TEST CIRCUITS AND WAVEFORMS (Cont.)

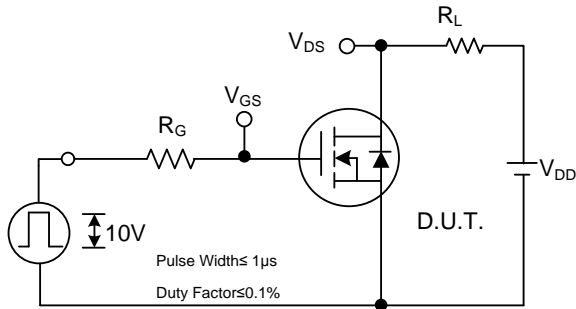

Switching Test Circuit

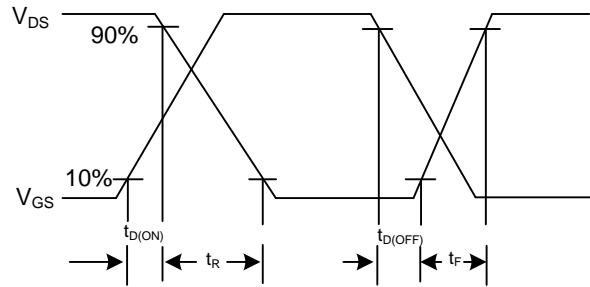

Switching Waveforms

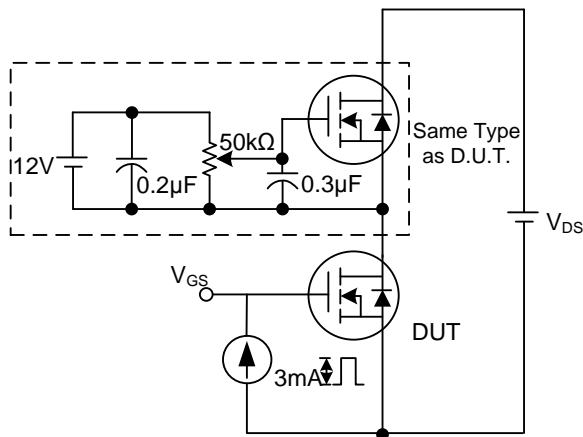

Gate Charge Test Circuit

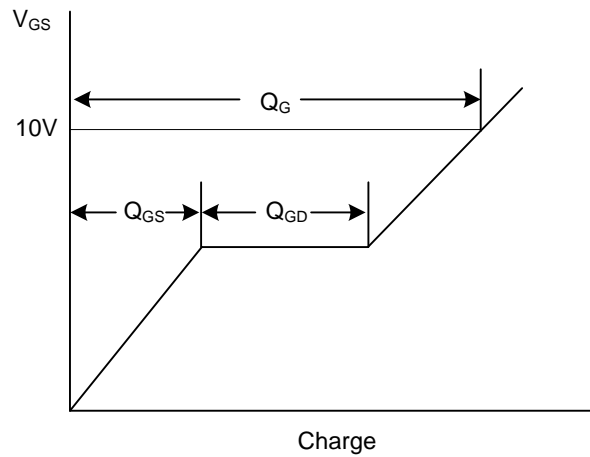

Gate Charge Waveform

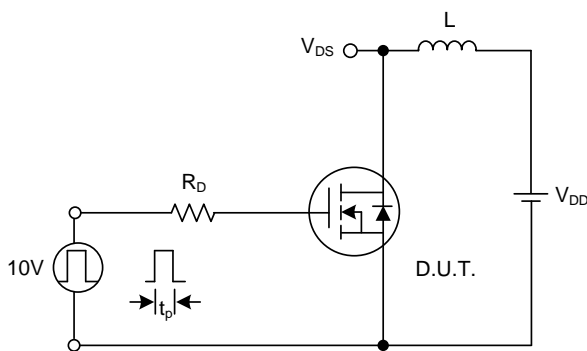

Unclamped Inductive Switching Test Circuit

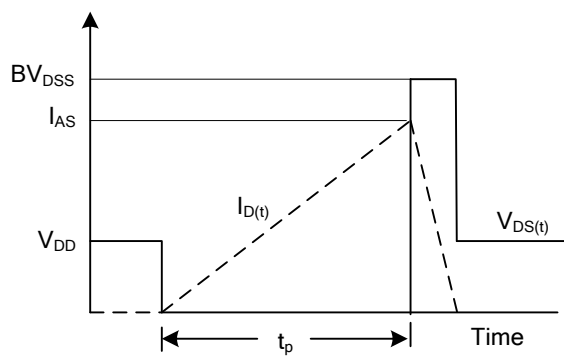

Unclamped Inductive Switching Waveforms

UTC assumes no responsibility for equipment failures that result from using products at values that exceed, even momentarily, rated values (such as maximum ratings, operating condition ranges, or other parameters) listed in products specifications of any and all UTC products described or contained herein. UTC products are not designed for use in life support appliances, devices or systems where malfunction of these products can be reasonably expected to result in personal injury. Reproduction in whole or in part is prohibited without the prior written consent of the copyright owner. UTC reserves the right to make changes to information published in this document, including without limitation specifications and product descriptions, at any time and without notice. This document supersedes and replaces all information supplied prior to the publication hereof.