



5NM80

Power MOSFET

5A, 800V N-CHANNEL SUPER-JUNCTION MOSFET

DESCRIPTION

The UTC 5NM80 is a Super Junction MOSFET Structure and is designed to have better characteristics, such as fast switching time, low gate charge, low on-state resistance and a high rugged avalanche characteristics. This power MOSFET is usually used at AC-DC converters for power applications.

FEATURES

- * $R_{DS(ON)} \leq 1.62 \Omega @ V_{GS}=10V, I_D=2.5A$
- * Fast switching capability
- * Avalanche energy tested
- * Improved dv/dt capability, high ruggedness

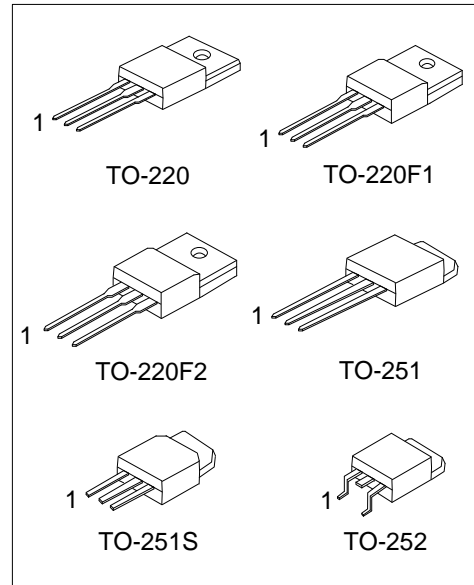

SYMBOL

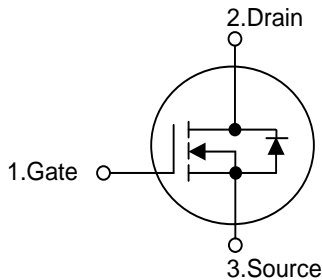

ORDERING INFORMATION

Ordering Number		Package	Pin Assignment			Packing
Lead Free	Halogen Free		1	2	3	
5NM80L-TA3-T	5NM80G-TA3-T	TO-220	G	D	S	Tube
5NM80L-TF1-T	5NM80G-TF1-T	TO-220F1	G	D	S	Tube
5NM80L-TF2-T	5NM80G-TF2-T	TO-220F2	G	D	S	Tube
5NM80L-TM3-T	5NM80G-TM3-T	TO-251	G	D	S	Tube
5NM80L-TMS-T	5NM80G-TMS-T	TO-251S	G	D	S	Tube
5NM80L-TN3-R	5NM80G-TN3-R	TO-252	G	D	S	Tape Reel

Note: Pin Assignment: G: Gate D: Drain S: Source

<p>5NM80G-TA3-T</p> <p>(1) Packing Type (2) Package Type (3) Green Package</p>	<p>(1) T: Tube, R: Tape Reel (2) TA3: TO-220, TF1: TO-220F1, TF2: TO-220F2 TM3: TO-251, TMS: TO-251S, TN3: TO-252 (3) G: Halogen Free and Lead Free, L: Lead Free</p>
--	---

MARKING

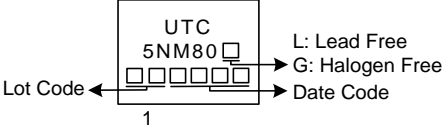

■ ABSOLUTE MAXIMUM RATINGS ($T_C = 25^\circ\text{C}$, unless otherwise specified)

PARAMETER		SYMBOL	RATINGS	UNIT	
Drain-Source Voltage		V_{DSS}	800	V	
Gate-Source Voltage		V_{GSS}	± 30	V	
Drain Current	Continuous	I_D	$T_C=25^\circ\text{C}$	5	A
			$T_C=100^\circ\text{C}$	3	A
	Pulsed (Note 2)		I_{DM}	10	A
Avalanche Current (Note 2)		I_{AR}	1.6	A	
Avalanche Energy	Single Pulsed (Note 3)	E_{AS}	48	mJ	
Peak Diode Recovery dv/dt (Note 4)		dv/dt	2.79	V/ns	
Power Dissipation	TO-220	P_D	42	W	
	TO-220F1/TO-220F2		24	W	
	TO-251/TO-251S		36	W	
	TO-252				
Junction Temperature		T_J	+150	$^\circ\text{C}$	
Storage Temperature		T_{STG}	-55 ~ +150	$^\circ\text{C}$	

Notes: 1. Absolute maximum ratings are those values beyond which the device could be permanently damaged.

Absolute maximum ratings are stress ratings only and functional device operation is not implied.

2. Repetitive Rating: Pulse width limited by maximum junction temperature.

3. $L=10\text{mH}$, $I_{AS}=3.1\text{A}$, $V_{DD}=50\text{V}$, $R_G=25\ \Omega$, Starting $T_J = 25^\circ\text{C}$

4. $I_{SD} \leq 5.0\text{A}$, $di/dt \leq 200\text{A}/\mu\text{s}$, $V_{DD} \leq BV_{DSS}$, Starting $T_J = 25^\circ\text{C}$

■ THERMAL DATA

PARAMETER		SYMBOL	RATING	UNIT
Junction to Ambient	TO-220/TO-220F1 TO-220F2	θ_{JA}	62.5	$^\circ\text{C/W}$
	TO-251/TO-251S TO-252		110	$^\circ\text{C/W}$
Junction to Case	TO-220	θ_{JC}	2.98	$^\circ\text{C/W}$
	TO-220F1/TO-220F2		5.21	$^\circ\text{C/W}$
	TO-251/TO-251S		3.47 (Note)	$^\circ\text{C/W}$
	TO-252			

Note: Device mounted on FR-4 substrate PC board, 2oz copper, with 1inch square copper plate.

■ ELECTRICAL CHARACTERISTICS (T_J=25°C, unless otherwise specified)

PARAMETER	SYMBOL	TEST CONDITIONS	MIN	TYP	MAX	UNIT
OFF CHARACTERISTICS						
Drain-Source Breakdown Voltage	BV _{DSS}	V _{GS} = 0V, I _D = 250μA	800			V
Drain-Source Leakage Current	I _{DSS}	V _{DS} = 800V, V _{GS} = 0V			10	μA
Gate-Source Leakage Current	Forward	I _{GSS}			100	nA
	Reverse				V _{GS} = 30V, V _{DS} = 0V	
ON CHARACTERISTICS						
Gate Threshold Voltage	V _{GS(TH)}	V _{DS} = V _{GS} , I _D = 250μA	2.5		4.5	V
Static Drain-Source On-State Resistance	R _{DS(ON)}	V _{GS} = 10V, I _D = 2.5A			1.62	Ω
DYNAMIC CHARACTERISTICS						
Input Capacitance	C _{ISS}	V _{DS} =25V, V _{GS} =0V, f=1.0MHz		430		pF
Output Capacitance	C _{OSS}			230		pF
Reverse Transfer Capacitance	C _{RSS}			11		pF
SWITCHING CHARACTERISTICS						
Total Gate Charge (Note 1)	Q _G	V _{DS} =640V, I _D =5A, I _G =1mA V _{GS} =10V (Note 1,2)		18		nC
Gate to Source Charge	Q _{GS}			3.5		nC
Gate to Drain Charge	Q _{GD}			5.5		nC
Turn-ON Delay Time (Note 1)	t _{D(ON)}	V _{DD} =100V, V _{GS} =10V, I _D =5A, R _G =25Ω, (Note 1,2)		5		nS
Rise Time	t _R			18.5		nS
Turn-OFF Delay Time	t _{D(OFF)}			50		nS
Fall-Time	t _F			29.5		nS
SOURCE- DRAIN DIODE RATINGS AND CHARACTERISTICS						
Maximum Continuous Drain-Source Diode Forward Current	I _S				5	A
Maximum Pulsed Drain-Source Diode Forward Current	I _{SM}				20	A
Drain-Source Diode Forward Voltage (Note 1)	V _{SD}	I _S =5.0A, V _{GS} =0V			1.4	V
Body Diode Reverse Recovery Time (Note 1)	t _{rr}	I _S =5.0A, V _{GS} =0V		350		nS
Body Diode Reverse Recovery Charge	Q _{rr}		dI _F /dt=100A/μs		3.5	

Notes: 1. Pulse Test : Pulse width ≤ 300μs, Duty cycle ≤ 2%.

2. Essentially independent of operating ambient temperature.

■ TEST CIRCUITS AND WAVEFORMS

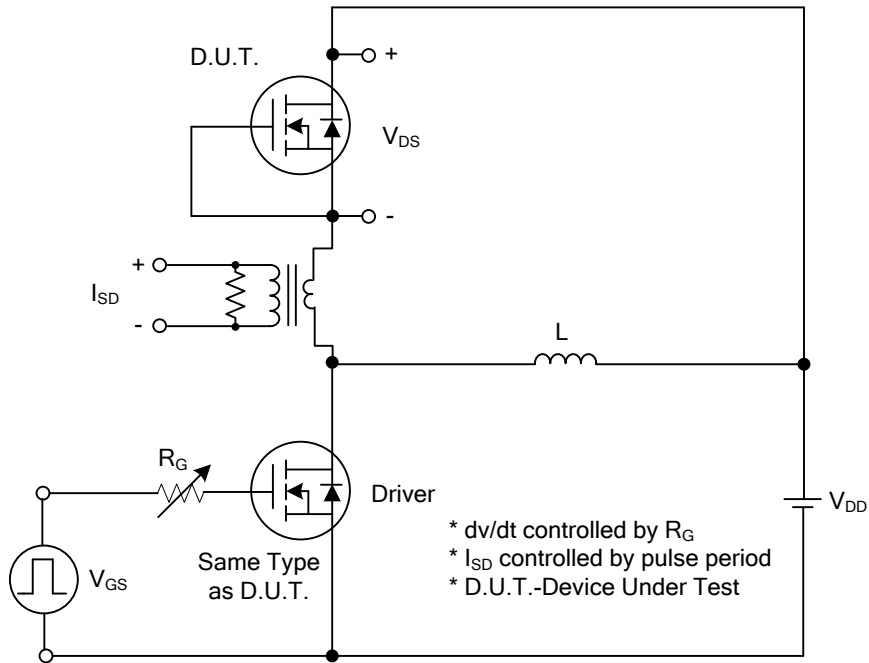

Peak Diode Recovery dv/dt Test Circuit

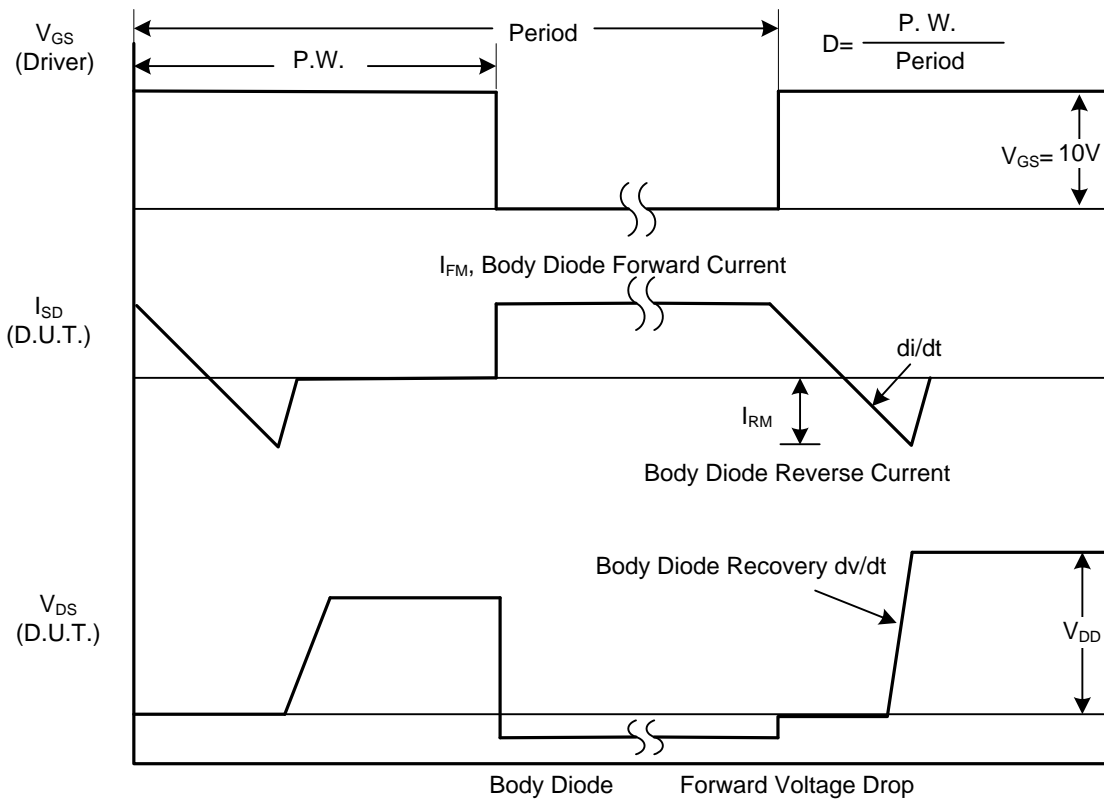

Peak Diode Recovery dv/dt Waveforms

TEST CIRCUITS AND WAVEFORMS

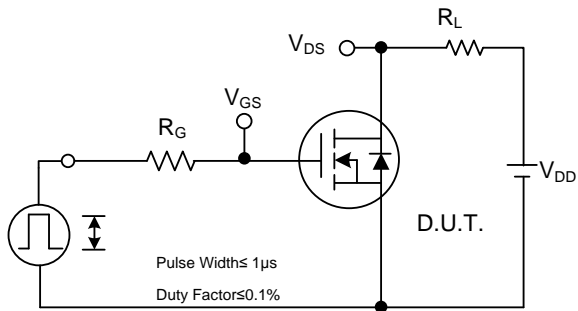

Switching Test Circuit

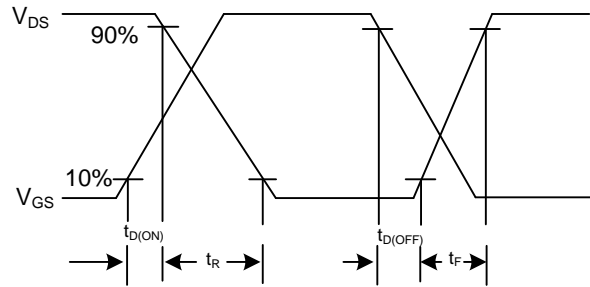

Switching Waveforms

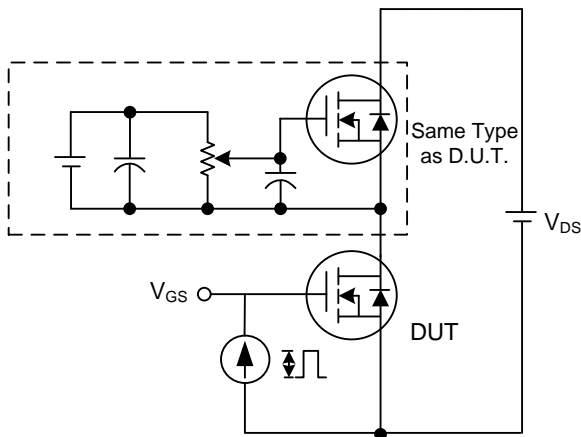

Gate Charge Test Circuit

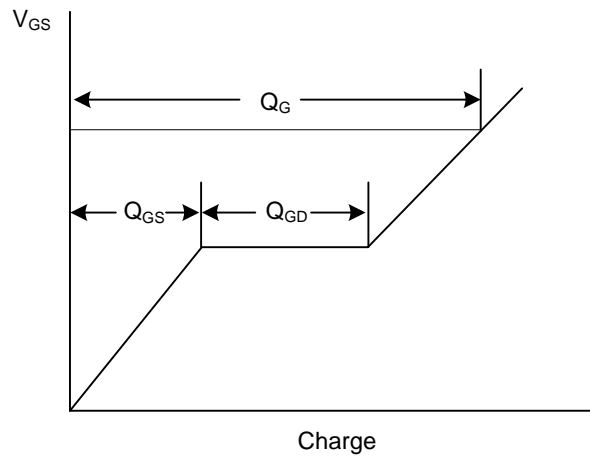

Gate Charge Waveform

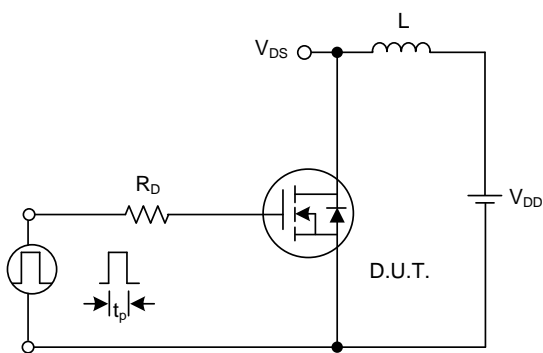

Unclamped Inductive Switching Test Circuit

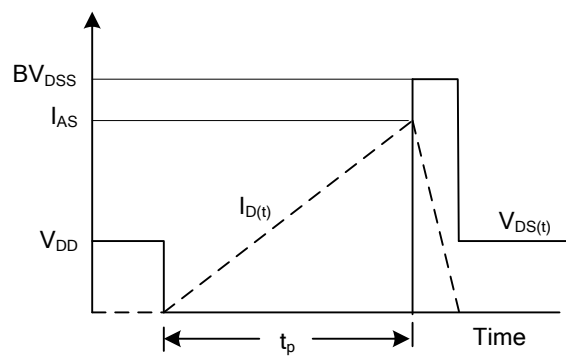

Unclamped Inductive Switching Waveforms

■ TYPICAL CHARACTERISTICS

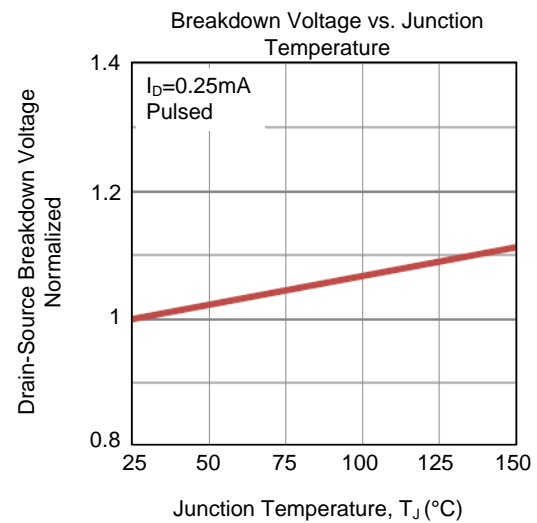
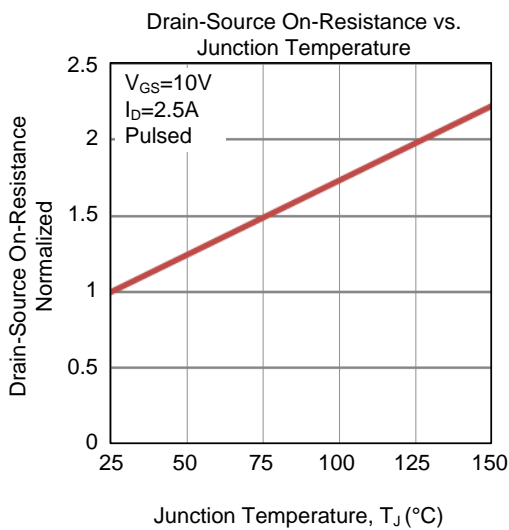
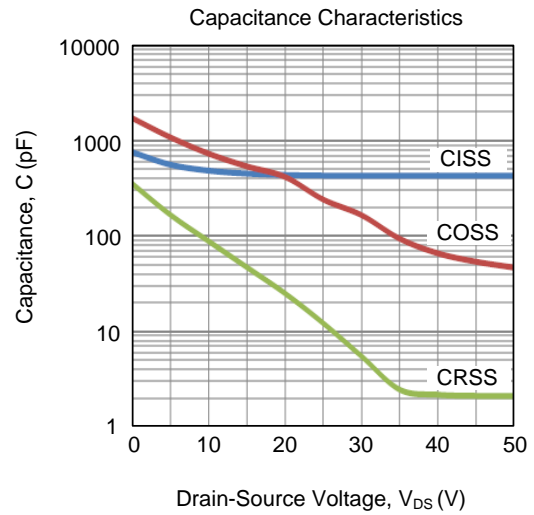
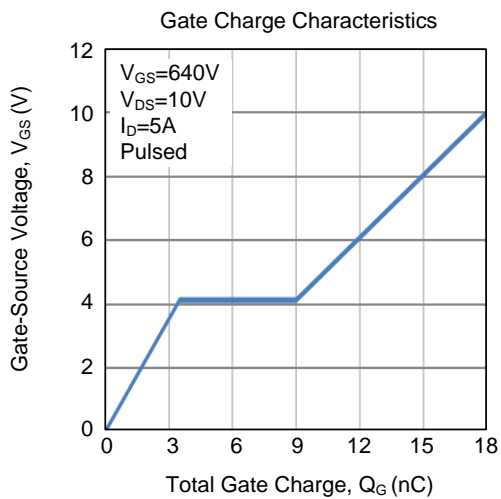
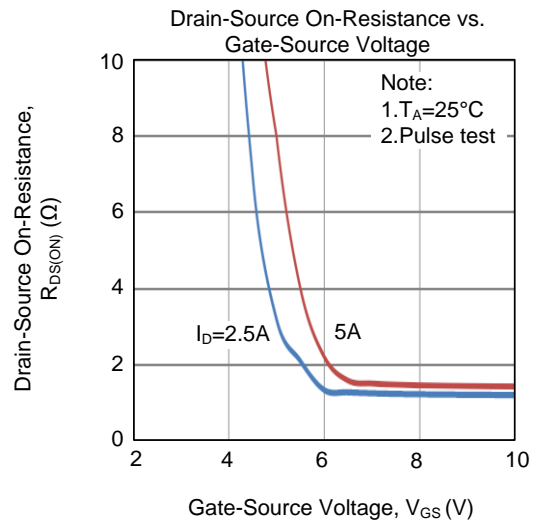
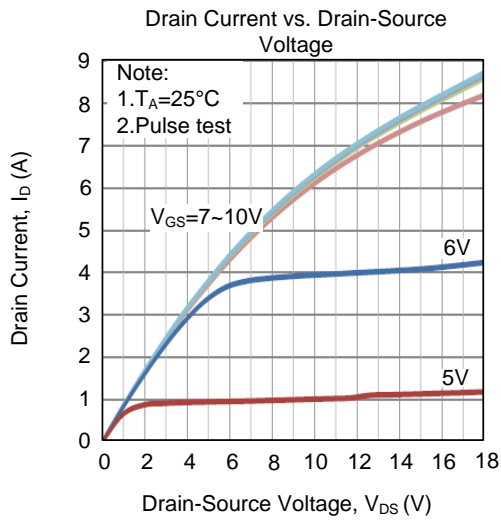

■ TYPICAL CHARACTERISTICS (Cont.)

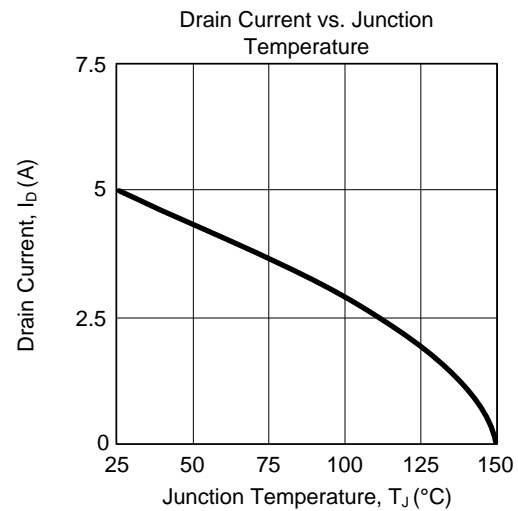
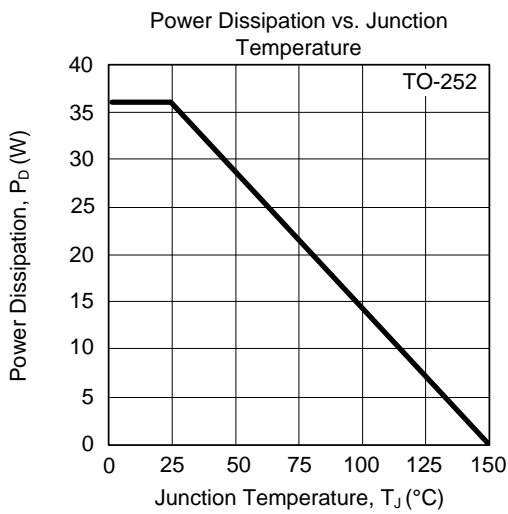
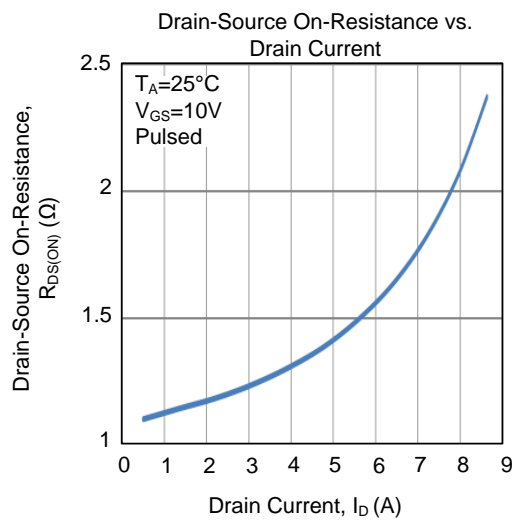
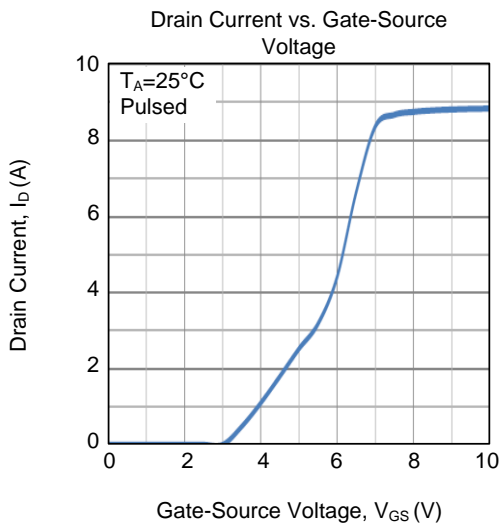
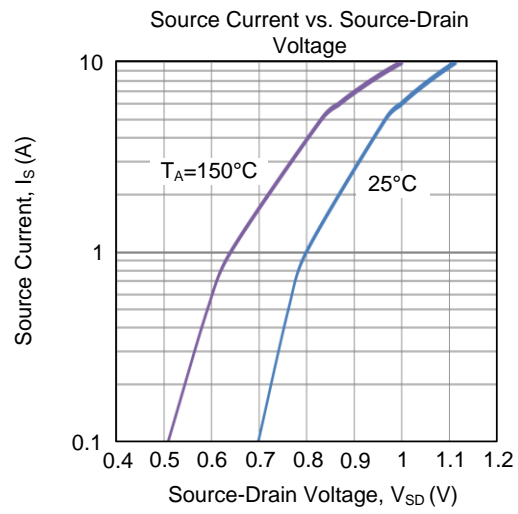
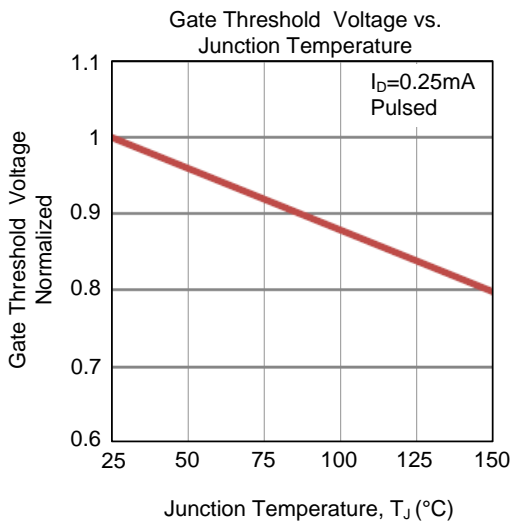

■ **TYPICAL CHARACTERISTICS (Cont.)**

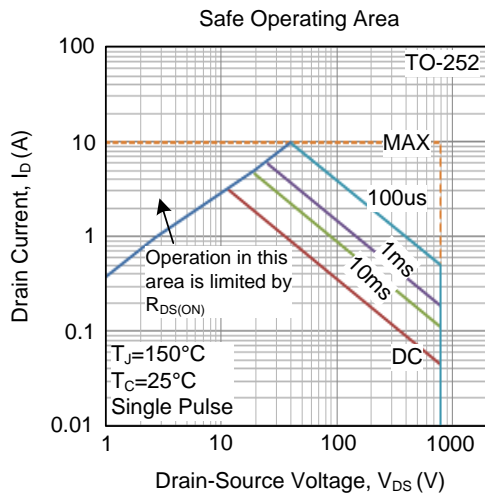

UTC assumes no responsibility for equipment failures that result from using products at values that exceed, even momentarily, rated values (such as maximum ratings, operating condition ranges, or other parameters) listed in products specifications of any and all UTC products described or contained herein. UTC products are not designed for use in life support appliances, devices or systems where malfunction of these products can be reasonably expected to result in personal injury. Reproduction in whole or in part is prohibited without the prior written consent of the copyright owner. UTC reserves the right to make changes to information published in this document, including without limitation specifications and product descriptions, at any time and without notice. This document supersedes and replaces all information supplied prior to the publication hereof.