



24NM50

Preliminary

Power MOSFET

24A, 500V N-CHANNEL SUPER-JUNCTION MOSFET

DESCRIPTION

The UTC 24NM50 is a Super Junction MOSFET Structure and is designed to have better characteristics, such as fast switching time, low gate charge, low on-state resistance and a high rugged avalanche characteristics. This power MOSFET is usually used at AC-DC converters for power applications.

FEATURES

- * $R_{DS(ON)} \leq 0.125 \Omega$ @ $V_{GS}=10V, I_D=12A$
- * High Switching Speed
- * 100% Avalanche Tested

SYMBOL

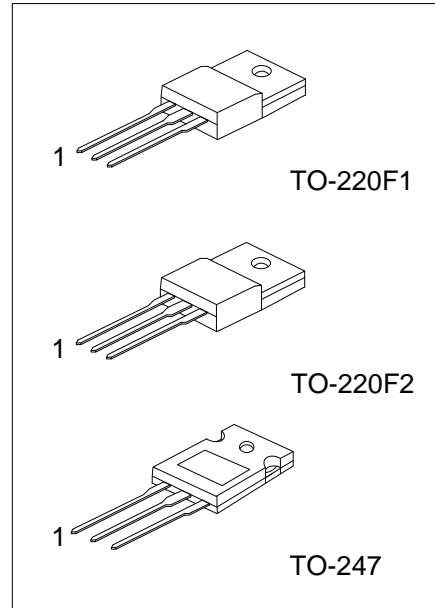
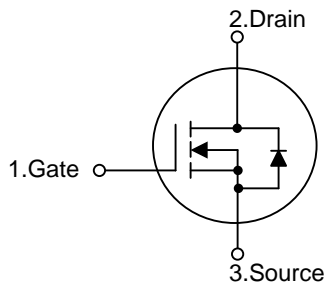

ORDERING INFORMATION

Ordering Number		Package	Pin Assignment			Packing
Lead Free	Halogen Free		1	2	3	
24NM50L-TF1-T	24NM50G-TF1-T	TO-220F1	G	D	S	Tube
24NM50L-TF2-T	24NM50G-TF2-T	TO-220F2	G	D	S	Tube
24NM50L-T47-T	24NM50G-T47-T	TO-247	G	D	S	Tube

Note: Pin Assignment: G: Gate D: Drain S: Source

<p>24NM50G-TF1-T</p>	<p>(1) T: Tube</p> <p>(2) TF1: TO-220F1, TF2: TO-220F2, T47: TO-247</p> <p>(3) G: Halogen Free and Lead Free, L: Lead Free</p>
----------------------	--

MARKING

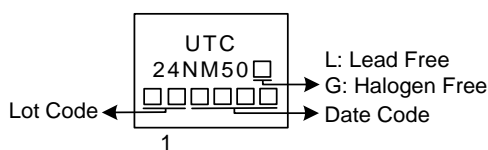

■ **ABSOLUTE MAXIMUM RATINGS** ($T_C=25^\circ\text{C}$, unless otherwise specified)

PARAMETER		SYMBOL	RATINGS	UNIT
Drain-Source Voltage		V_{DSS}	500	V
Gate-Source Voltage		V_{GSS}	± 30	V
Drain Current	Continuous	I_D	24	A
	Pulsed (Note 2)	I_{DM}	96	A
Avalanche Current (Note 2)		I_{AR}	10.4	A
Avalanche Energy		E_{AS}	648	mJ
Peak Diode Recovery dv/dt (Note 4)		dv/dt	8.7	V/ns
Power Dissipation	TO-220F1/TO-220F2	P_D	45	W
	TO-247		200	W
Junction Temperature		T_J	+150	$^\circ\text{C}$
Storage Temperature		T_{STG}	-55 ~ +150	$^\circ\text{C}$

Notes: 1. Absolute maximum ratings are those values beyond which the device could be permanently damaged.

Absolute maximum ratings are stress ratings only and functional device operation is not implied.

2. Repetitive Rating: Pulse width limited by maximum junction temperature.

3. $L = 12\text{mH}$, $I_{AS} = 10.4\text{A}$, $V_{DD} = 50\text{V}$, $R_G = 25\Omega$, Starting $T_J = 25^\circ\text{C}$

4. $I_{SD} \leq 24\text{A}$, $di/dt \leq 200\text{A}/\mu\text{s}$, $V_{DD} \leq BV_{DSS}$, Starting $T_J = 25^\circ\text{C}$

■ **THERMAL DATA**

PARAMETER		SYMBOL	RATINGS	UNIT
Junction to Ambient	TO-220F1/TO-220F2	θ_{JA}	62.5	$^\circ\text{C}/\text{W}$
	TO-247		25	$^\circ\text{C}/\text{W}$
Junction to Case	TO-220F1/TO-220F2	θ_{JC}	2.7	$^\circ\text{C}/\text{W}$
	TO-247		0.6	$^\circ\text{C}/\text{W}$

■ **ELECTRICAL CHARACTERISTICS** ($T_J = 25^\circ\text{C}$, unless otherwise specified)

PARAMETER	SYMBOL	TEST CONDITIONS	MIN	TYP	MAX	UNIT
OFF CHARACTERISTICS						
Drain-Source Breakdown Voltage	BV_{DSS}	$I_D=250\mu\text{A}$, $V_{GS}=0\text{V}$	500			V
Drain-Source Leakage Current	I_{DSS}	$V_{DS}=500\text{V}$, $V_{GS}=0\text{V}$			50	μA
Gate- Source Leakage Current	Forward	I_{GSS} , $V_{GS}=+30\text{V}$, $V_{DS}=0\text{V}$			+100	nA
	Reverse	$V_{GS}=-30\text{V}$, $V_{DS}=0\text{V}$			-100	nA
ON CHARACTERISTICS						
Gate Threshold Voltage	$V_{GS(TH)}$	$V_{DS}=V_{GS}$, $I_D=250\mu\text{A}$	2.5		4.5	V
Static Drain-Source On-State Resistance	$R_{DS(ON)}$	$V_{GS}=10\text{V}$, $I_D=12\text{A}$			0.125	Ω
DYNAMIC PARAMETERS						
Input Capacitance	C_{ISS}	$V_{GS}=0\text{V}$, $V_{DS}=25\text{V}$, $f=1.0\text{MHz}$		2260		pF
Output Capacitance	C_{OSS}			1550		pF
Reverse Transfer Capacitance	C_{RSS}			140		pF
SWITCHING PARAMETERS						
Total Gate Charge (Note 1)	Q_G	$V_{DS}=30\text{V}$, $V_{GS}=10\text{V}$, $I_D=10\text{A}$ $I_G=100\mu\text{A}$ (Note 1, 2)		190		nC
Gate to Source Charge	Q_{GS}			10		nC
Gate to Drain Charge	Q_{GD}			50		nC
Turn-ON Delay Time (Note 1)	$t_{D(ON)}$	$V_{DS}=50\text{V}$, $V_{GS}=10\text{V}$, $I_D=0.5\text{A}$, $R_G=25\Omega$ (Note 1, 2)		96		ns
Rise Time	t_R			305		ns
Turn-OFF Delay Time	$t_{D(OFF)}$			710		ns
Fall-Time	t_F			440		ns
SOURCE- DRAIN DIODE RATINGS AND CHARACTERISTICS						
Maximum Body-Diode Continuous Current	I_S				24	A
Maximum Body-Diode Pulsed Current	I_{SM}				96	A
Drain-Source Diode Forward Voltage (Note 1)	V_{SD}	$I_S=24\text{A}$, $V_{GS}=0\text{V}$			1.4	V
Body Diode Reverse Recovery Time (Note 1)	t_{rr}	$I_S=24\text{A}$, $V_{GS}=0\text{V}$, $di_F/dt=100\text{A}/\mu\text{s}$		470		ns
Body Diode Reverse Recovery Charge	Q_{rr}				8.6	

Notes: 1. Pulse Test : Pulse width $\leq 300\mu\text{s}$, Duty cycle $\leq 2\%$.

2. Essentially independent of operating ambient temperature.

■ TEST CIRCUITS AND WAVEFORMS

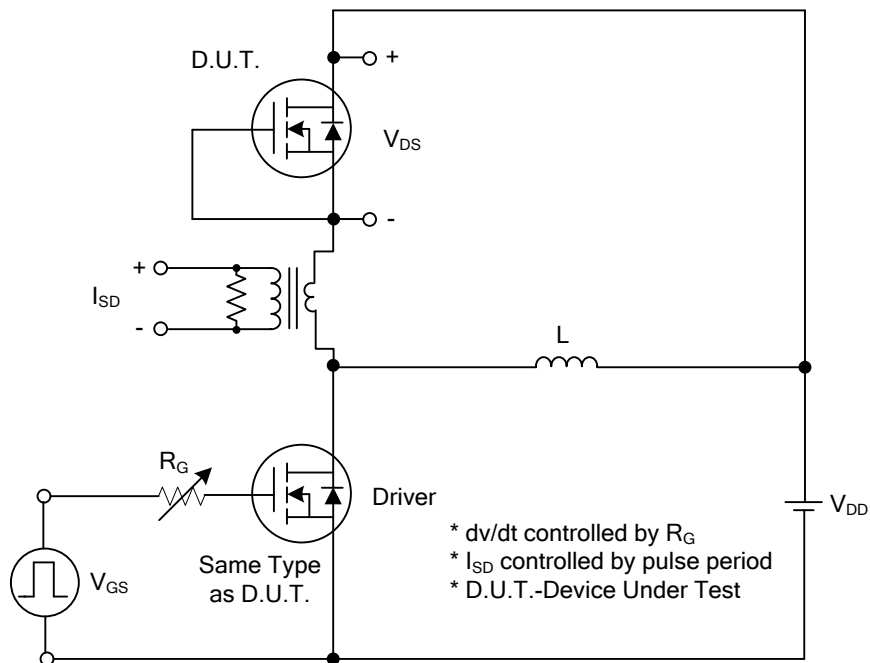

Peak Diode Recovery dv/dt Test Circuit

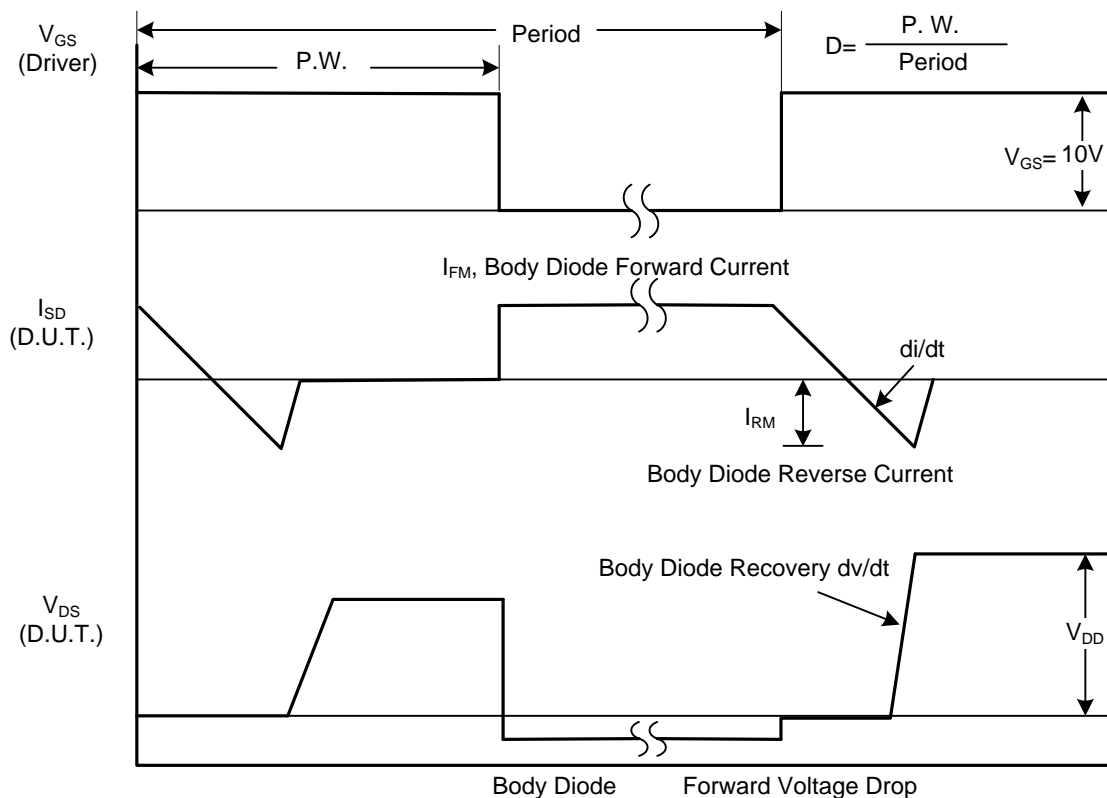

Peak Diode Recovery dv/dt Waveforms

■ TEST CIRCUITS AND WAVEFORMS (Cont.)

Gate Charge Test Circuit

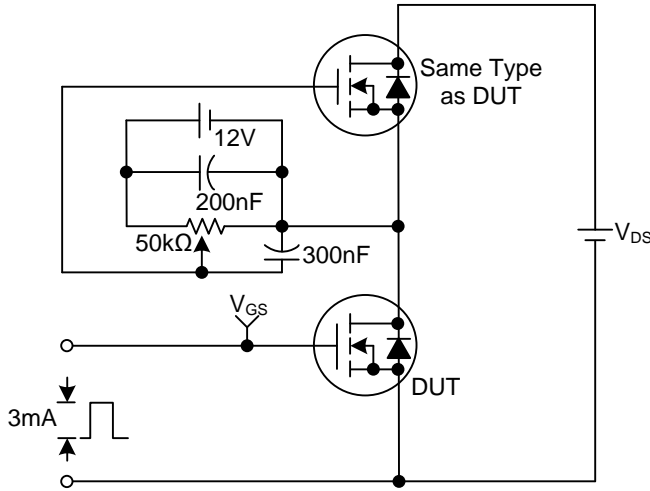

Gate Charge Waveforms

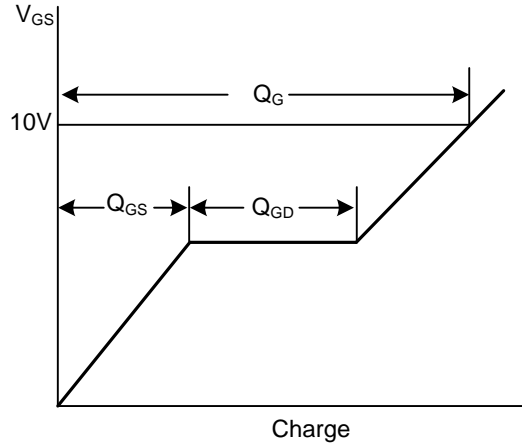

Resistive Switching Test Circuit

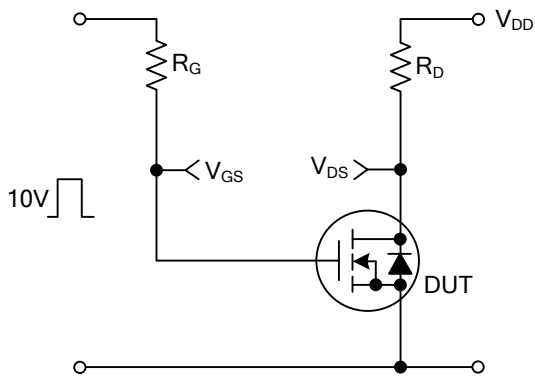

Resistive Switching Waveforms

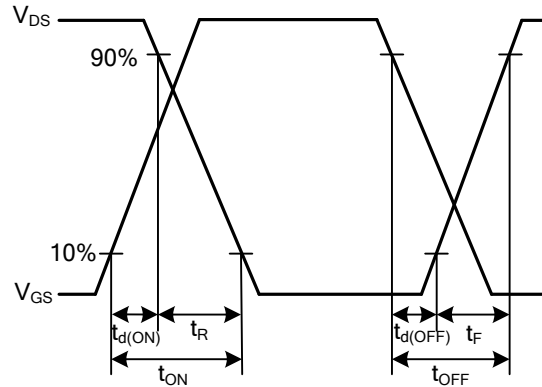

Unclamped Inductive Switching Test Circuit

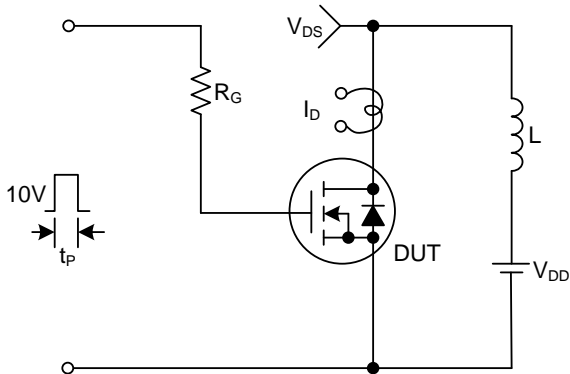

Unclamped Inductive Switching Waveforms

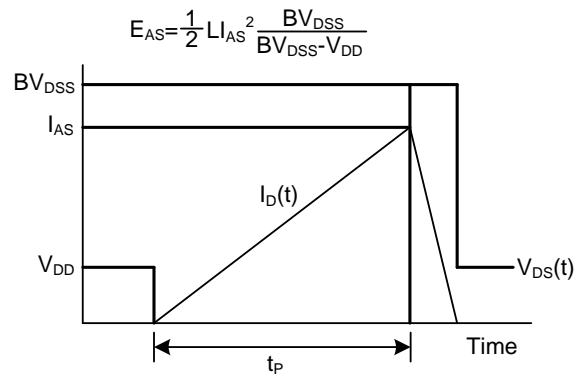

UTC assumes no responsibility for equipment failures that result from using products at values that exceed, even momentarily, rated values (such as maximum ratings, operating condition ranges, or other parameters) listed in products specifications of any and all UTC products described or contained herein. UTC products are not designed for use in life support appliances, devices or systems where malfunction of these products can be reasonably expected to result in personal injury. Reproduction in whole or in part is prohibited without the prior written consent of the copyright owner. UTC reserves the right to make changes to information published in this document, including without limitation specifications and product descriptions, at any time and without notice. This document supersedes and replaces all information supplied prior to the publication hereof.