



4NM60A

Preliminary

Power MOSFET

4.0A, 600V N-CHANNEL SUPER-JUNCTION MOSFET

■ DESCRIPTION

The **UTC 4NM60A** is a Super Junction MOSFET Structure and is designed to have better characteristics, such as fast switching time, low gate charge, low on-state resistance and a high rugged avalanche characteristics. This power MOSFET is usually used at DC-DC, AC-DC converters for power applications.

■ FEATURES

- * $R_{DS(ON)} < 1.4\Omega @ V_{GS} = 10V, I_D = 2.0A$
- * Fast Switching Capability
- * Avalanche Energy Specified
- * Improved dv/dt Capability, High Ruggedness

■ SYMBOL

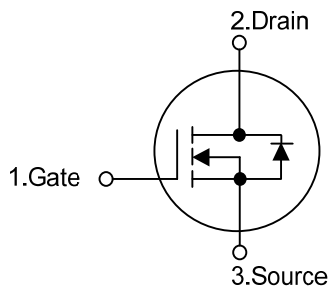

■ ORDERING INFORMATION

Ordering Number		Package	Pin Assignment			Packing
Lead Free	Halogen Free		1	2	3	
4NM60AL-TA3-T	4NM60AG-TA3-T	TO-220	G	D	S	Tube
4NM60AL-TF3-T	4NM60AG-TF3-T	TO-220F	G	D	S	Tube
4NM60AL-TF1-T	4NM60AG-TF1-T	TO-220F1	G	D	S	Tube
4NM60AL-TF2-T	4NM60AG-TF2-T	TO-220F2	G	D	S	Tube
4NM60AL-TM3-T	4NM60AG-TM3-T	TO-251	G	D	S	Tube
4NM60AL-TMS-T	4NM60AG-TMS-T	TO-251S	G	D	S	Tube
4NM60AL-TN3-R	4NM60AG-TN3-R	TO-252	G	D	S	Tape Reel

Note: Pin Assignment: G: Gate D: Drain S: Source

<p>4NM60AL-TA3-T</p> <p>(1)Packing Type (2)Package Type (3)Green Package</p>	<p>(1) T: Tube, R: Tape Reel (2) TA3: TO-220, TF3: TO-220F, TF1: TO-220F1, TF2: TO-220F2, TM3: TO-251, TMS: TO-251S, TN3: TO-252 (3) L: Lead Free, G: Halogen Free and Lead Free</p>
--	--

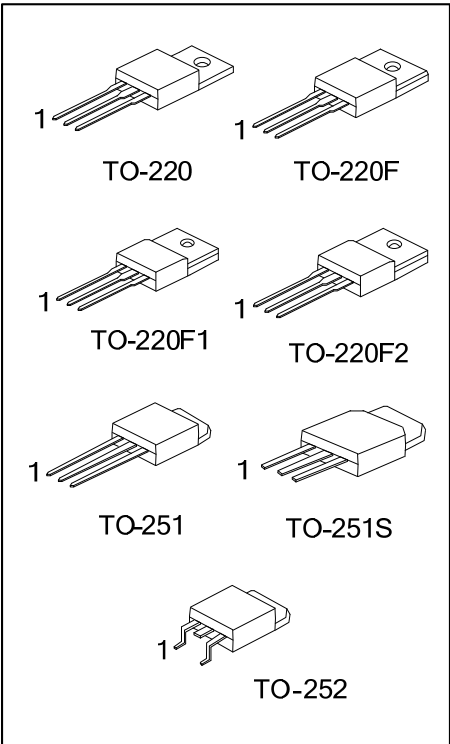

MARKING

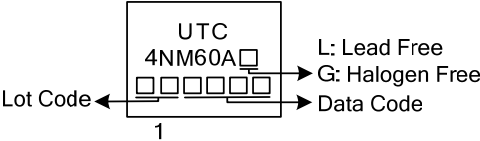

■ ABSOLUTE MAXIMUM RATINGS ($T_C = 25^\circ\text{C}$, unless otherwise specified)

PARAMETER		SYMBOL	RATINGS	UNIT
Drain-Source Voltage		V_{DSS}	600	V
Gate-Source Voltage		V_{GSS}	± 30	V
Drain Current	Continuous	I_D	4.0	A
	Pulsed (Note2)	I_{DM}	16	A
Avalanche Current (Note 2)		I_{AR}	1.3	A
Avalanche Energy	Single Pulsed (Note3)	E_{AS}	122	mJ
Peak Diode Recovery dv/dt (Note4)		dv/dt	4.6	V/ns
Power Dissipation	TO-220	P_D	106	W
	TO-220F		34	W
	TO-220F1/TO-220F2		36	W
	TO-251/TO-251S		50	W
	TO-252			
Junction Temperature		T_J	+150	$^\circ\text{C}$
Storage Temperature		T_{STG}	-55 ~ +150	$^\circ\text{C}$

Notes: 1. Absolute maximum ratings are those values beyond which the device could be permanently damaged.

Absolute maximum ratings are stress ratings only and functional device operation is not implied.

2. Repetitive Rating : Pulse width limited by maximum junction temperature.

3. $L=144\text{mH}$, $I_{AS}=1.3\text{A}$, $V_{DD}=50\text{V}$, $R_G=25\ \Omega$, Starting $T_J = 25^\circ\text{C}$

4. $I_{SD}\leq 4.0\text{A}$, $di/dt\leq 200\text{A}/\mu\text{s}$, $V_{DD}\leq BV_{DSS}$, Starting $T_J = 25^\circ\text{C}$

■ THERMAL RESISTANCES CHARACTERISTICS

PARAMETER		SYMBOL	RATINGS	UNIT
Junction to Ambient	TO-220/TO-220F TO-220F1/TO-220F2	θ_{JA}	62.5	$^\circ\text{C}/\text{W}$
	TO-251/TO-251S TO-252		110	$^\circ\text{C}/\text{W}$
	TO-220		1.18	$^\circ\text{C}/\text{W}$
Junction to Case	TO-220F/TO-220F1	θ_{JC}	3.67	$^\circ\text{C}/\text{W}$
	TO-220F2		3.47	$^\circ\text{C}/\text{W}$
	TO-251/TO-251S		2.5	$^\circ\text{C}/\text{W}$
	TO-252			

■ ELECTRICAL CHARACTERISTICS ($T_J = 25^\circ\text{C}$, unless otherwise specified)

PARAMETER	SYMBOL	TEST CONDITIONS	MIN	TYP	MAX	UNIT
OFF CHARACTERISTICS						
Drain-Source Breakdown Voltage	BV_{DSS}	$V_{GS} = 0\text{ V}, I_D = 250\mu\text{A}$	600			V
Drain-Source Leakage Current	I_{DSS}	$V_{DS} = 600\text{ V}, V_{GS} = 0\text{ V}$			10	μA
Gate-Source Leakage Current	Forward	I_{GSS}			100	nA
	Reverse					
		$V_{GS} = -30\text{ V}, V_{DS} = 0\text{ V}$			-100	nA
ON CHARACTERISTICS						
Gate Threshold Voltage	$V_{GS(TH)}$	$V_{DS} = V_{GS}, I_D = 250\mu\text{A}$	2.5		4.5	V
Static Drain-Source On-State Resistance	$R_{DS(ON)}$	$V_{GS} = 10\text{ V}, I_D = 2.0\text{A}$			1.4	Ω
DYNAMIC CHARACTERISTICS						
Input Capacitance	C_{ISS}	$V_{GS} = 0\text{V}, V_{DS} = 25\text{V}, f = 1\text{MHz}$		256		pF
Output Capacitance	C_{OSS}			165		pF
Reverse Transfer Capacitance	C_{RSS}			16		pF
SWITCHING CHARACTERISTICS						
Total Gate Charge (Note 1)	Q_G	$V_{DS} = 50\text{V}, V_{GS} = 10\text{V}, I_D = 1.3\text{A}, I_G = 100\mu\text{A}$ (Note 1, 2)		37.5		nC
Gate to Source Charge	Q_{GS}			4.0		nC
Gate to Drain Charge	Q_{GD}			8.0		nC
Turn-ON Delay Time (Note 1)	$t_{D(ON)}$	$V_{DD} = 30\text{V}, V_{GS} = 10\text{V}, I_D = 0.5\text{A}, R_G = 25\Omega$ (Note 1, 2)		40		ns
Rise Time	t_R			50		ns
Turn-OFF Delay Time	$t_{D(OFF)}$			100		ns
Fall-Time	t_F			35		ns
SOURCE- DRAIN DIODE RATINGS AND CHARACTERISTICS						
Maximum Body-Diode Continuous Current	I_S				4.0	A
Maximum Body-Diode Pulsed Current	I_{SM}				16	A
Drain-Source Diode Forward Voltage (Note 1)	V_{SD}	$I_S = 4.0\text{A}, V_{GS} = 0\text{V}$			1.4	V
Body Diode Reverse Recovery Time (Note 1)	t_{rr}	$I_S = 4.0\text{A}, V_{GS} = 0\text{V}$		240		ns
Body Diode Reverse Recovery Charge	Q_{rr}	$di_F/dt = 100\text{A}/\mu\text{s}$		1.9		μC

Notes: 1. Pulse Test: Pulse width $\leq 300\mu\text{s}$, Duty cycle $\leq 2\%$

2. Essentially independent of operating temperature

■ TEST CIRCUITS AND WAVEFORMS

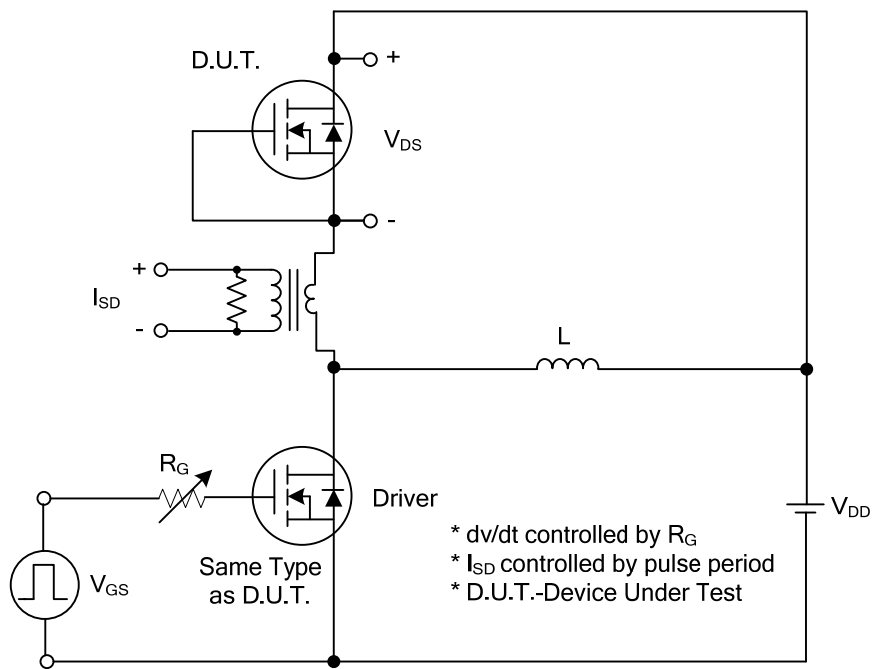

Peak Diode Recovery dv/dt Test Circuit

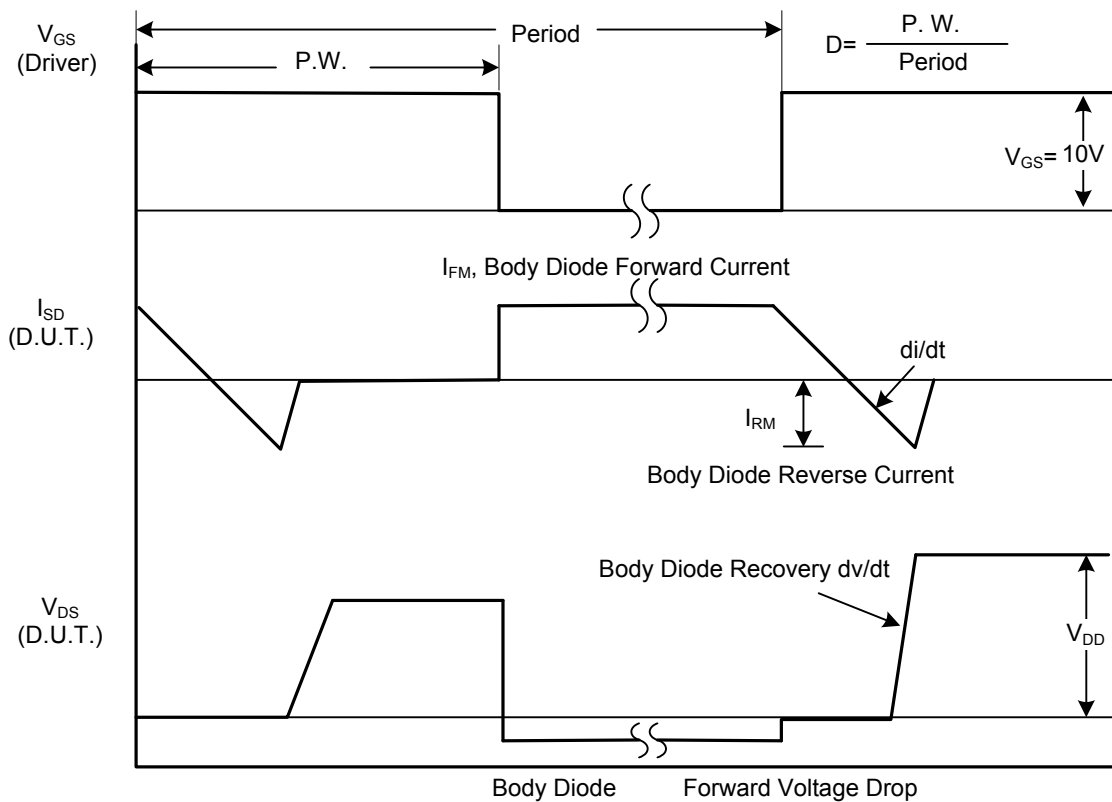

Peak Diode Recovery dv/dt Waveforms

■ TEST CIRCUITS AND WAVEFORMS (Cont.)

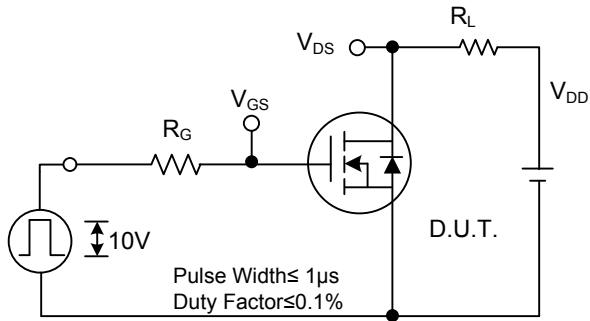

Switching Test Circuit

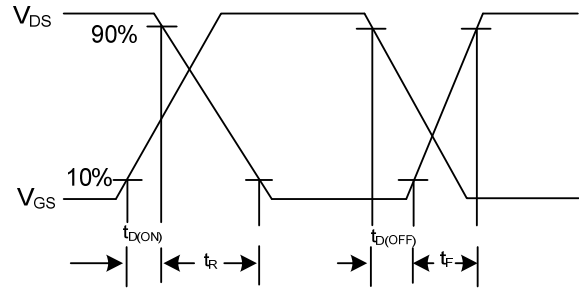

Switching Waveforms

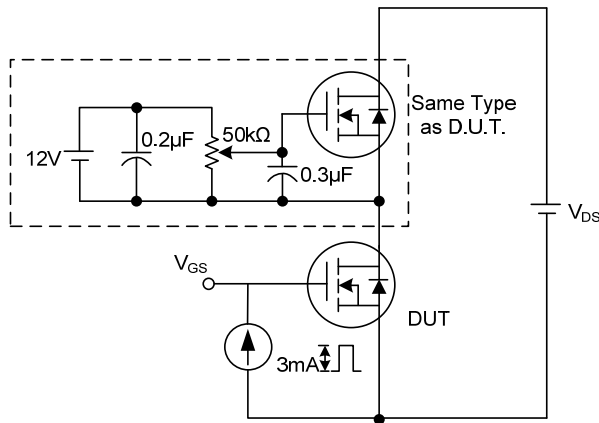

Gate Charge Test Circuit

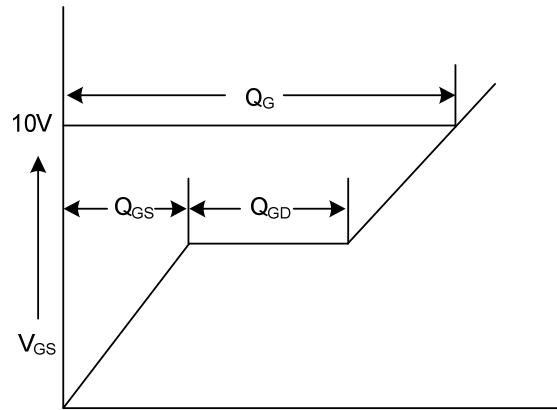

Gate Charge Waveform

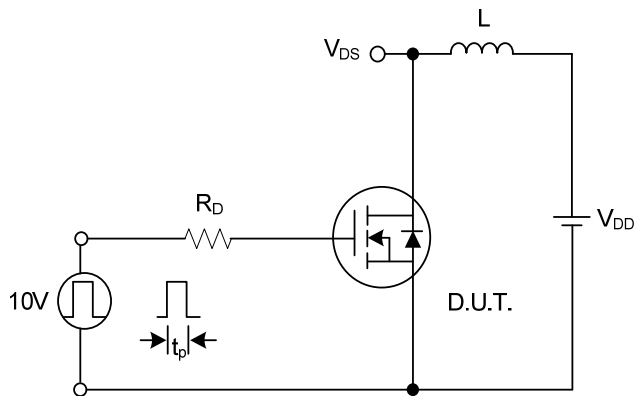

Unclamped Inductive Switching Test Circuit

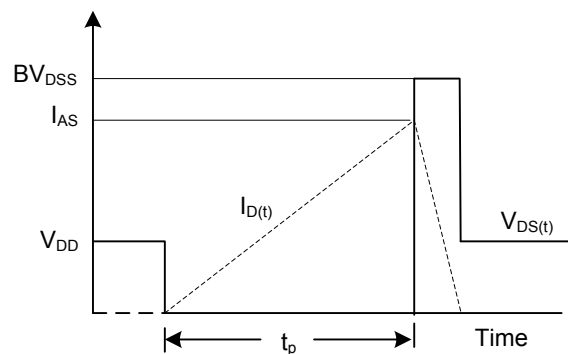

Unclamped Inductive Switching Waveforms

UTC assumes no responsibility for equipment failures that result from using products at values that exceed, even momentarily, rated values (such as maximum ratings, operating condition ranges, or other parameters) listed in products specifications of any and all UTC products described or contained herein. UTC products are not designed for use in life support appliances, devices or systems where malfunction of these products can be reasonably expected to result in personal injury. Reproduction in whole or in part is prohibited without the prior written consent of the copyright owner. The information presented in this document does not form part of any quotation or contract, is believed to be accurate and reliable and may be changed without notice.